

Republic of the Philippines
EULOGIO "AMANG" RODRIGUEZ
INSTITUTE OF SCIENCE AND TECHNOLOGY
Nagtahan, Sampaloc Manila

VOLUME XXIV, No. 35

ISSN 0119-5212

JANUARY - JUNE 2024



EARIST RESEARCH JOURNAL

*"Collaboration and Innovation For Sustainable
Futures: Building Resilience In A Changing World"*



The EARIST Research Journal seeks to further the discussion, advancement, and dissemination of research, planning, development and production concerns and knowledge along professional, scientific, technological, technical and vocational instruction and training in trades, business, arts, sciences and technology.

The opinions expressed in the articles are those of the author or authors; they are not necessarily the views of Eulogio “Amang” Rodriguez Institute of Science and Technology, and the Office of the EARIST Research Services.

Correspondence concerning contributions, subscriptions, advertising, permission to reprint the articles, and other business matters should be addressed to EARIST Research Services.

FOREWORD

The Eulogio “Amang” Rodriguez Institute of Science and Technology takes pride in publishing Volume XXIV, No. 35, January – June 2024 of the EARIST Research Journal as it contributes to the attainment of EARIST’s Mission, Vision, Goals, and Objectives through scholarly publications.

This volume is the output of researches conducted by EARIST faculty during the Academic Year 2024. This volume highlighted Nineteen (19) distinct researches in different fields, but most noteworthy, each individual research achievement.

The topics vary as shown in every page, but each is full of diverse stories confirming happenings in every college of the Institute. The office of research hopes to mirror the activities of our educators in assuming their task as researchers.

There are more challenges left in the various fields waiting for further scrutiny. We continue the never-ending cycle of the quest for new knowledge and further understanding of the issues at hand. The work remains unsolved. But unless we produce our own solutions to existing problems, the challenges will never be met.

The research work undertaken by faculty members and staff are included with the hope that these will contribute to the advancement of research activities of the institute and will serve as medium in the dissemination of research outputs to the community.

Dr. Marlene M. Monterona
Director, Research Services

TABLE OF CONTENTS

FOREWORD	i
TABLE OF CONTENTS	ii
TECHNICAL RESEARCH	1
TEXT TRANSLATION: SIGN LANGUAGE MOTION DETECTION FOR FAST-FOOD ORDERING USING NEURAL NETWORKS	2
<i>Hazel F. Anuncio, Ador G. Utulo, and Minerva C. Zoleta</i>	
ACCEPTABILITY OF HOME MADE BLUE TERNATE ICE CREAM	9
<i>Ma. Lee D. de los Reyes</i>	
“BABEL”: A LANGUAGE TRANSLATOR MOBILE-BASED APPLICATION ..	11
<i>Catherine D. Dumpit</i>	
C++ QUIZ APPLICATION	14
<i>Catherine D. Dumpit and Richard Carl G. Alfaro</i>	
GMA CIVIL REGISTRAR ONLINE TRANSACTION SYSTEM	19
<i>Rowee M. Marfil</i>	
ON QUARTER SQUARE SEQUENCE	25
<i>Ramil L. Borres – Enrique Olonan and Associates</i>	
<i>Rodora T. Oliveros – Eulogio “Amang” Rodriguez Institute of Science and Technology</i>	
INVESTIGATING THE CHARACTERISTICS AND RELATIONSHIPS OF THE LEIBNIZ HARMONIC NUMBER	29
<i>John Martin G. Fontanilla and Joneil G. Pontejos</i>	
ON PROPERTIES AND RELATIONSHIPS OF THE GENERALIZED PYRAMIDAL NUMBER	32
<i>Carlos R. Avila and Larex B. Tagalog</i>	
ON DISMAL ARITHMETIC BOARD GAME	38
<i>Enrico P. Zara and Larex B. Tagalog</i>	
ANALYSIS AND ASSESSMENT ON THE SOCIAL AMELIORATION PROGRAM BENEFICIARIES IN BARANGAY 130 AND BARANGAY 131, CALOOCAN CITY USING NATURAL LANGUAGE PROGRAMMING	41
<i>Ador G. Utulo</i>	
PC – BASED SECURITY CAMERA WITH ALARM SYSTEM USING IMAGE PROCESSING.....	46
<i>Ador G. Utulo</i>	

BEHAVIORAL RESEARCH	54
QUALITY MANAGEMENT SYSTEM PRACTICES, ORGANIZATIONAL PERFORMANCE, AND EMPLOYEE ENGAGEMENT OF STATE UNIVERSITIES AND COLLEGES IN THE CALABARZON REGION: BASIS FOR A PROPOSED INTERVENTION PROGRAM <i>Rommuel E. Abanto</i>	55
PENOMENOLOHIKAL NA PAGSUSURI SA INTERKULTURAL NA DANAS NG MGA FILIPINO VIRTUAL ASSISTANT SA INTERNATIONAL COMPANY: BASEHAN SA PAGBUO NG INTERCULTURAL COMMUNICATION TRAINING PROGRAM <i>Joseph C. Anggot</i>	60
EXPLORING THE INFLUENCE OF STEM EDUCATION ON COLLEGE STUDENTS: AN ACTION RESEARCH <i>Daisy Mae R. Bongtiwon, Benjamin G. Haboc, Elsa R. Cagatan, and Eleonor T. Salvador</i>	67
PRACTICE-TEACHERS' MOTIVATIONAL APPROACH TO STUDENT ENGAGEMENT IN TECHNOLOGY AND LIVELIHOOD EDUCATION <i>Michael N. Buligan, Shirley P. De Leon, and Michael M. Borja</i>	77
RESPONSIBLE CONSUMPTION AND PRODUCTION IN THE PHILIPPINES POST-COVID-19 PANDEMIC: A QUALITATIVE EXPLORATION <i>Emerson G. Cabudol</i>	82
SOCIAL SUPPORT AND WELL-BEING OF PERSONS WITH DISABILITIES (PWD) OF GENERAL MARIANO ALVAREZ CAVITE: BASIS FOR INTERVENTION PROGRAM <i>Nancy G. Liwanag and Mark Joseph A. Viado</i>	92
POSTMILLENNIAL LEVEL OF COMMITMENT: A CASE OF WORKING STUDENTS IN BPO INDUSTRY <i>Hernan M. Oliveros</i>	97
LITERACY ON BASIC CONSUMER RIGHTS: BASIS FOR AWARENESS PROGRAM <i>Apple M. Rapada</i>	105



Technical Research

HEALTH CARE
TREATMENT
MEDICAL CARE
PREVENTION
DIAGNOSIS

RESEARCH
INNOVATION
TECHNOLOGY
IDEA
SOLUTION
INSPIRATION

TEXT TRANSLATION: SIGN LANGUAGE MOTION DETECTION FOR FAST-FOOD ORDERING USING NEURAL NETWORKS

*Hazel F. Anuncio
Ador G. Utulo
Minerva C. Zoleta*

INTRODUCTION

Hearing is one of the most essential human senses, yet some people were born deaf. Others were born mute and do not have the capability of communicating verbally. Their families try to make their lives comfortable despite their conditions by providing education using sign language as an alternative means of communication. It is difficult for people with this impairment to share and communicate with the general population because most people must acquire sign language, and others find it time-consuming unless it's necessary when a member of the family has hearing impairment. These physically challenged individuals would like to live a life on their own but most of the time experience difficulties in communicating with people unlike themselves. Purchasing basic needs such as food in restaurants or fast food chains is one of the challenges they commonly experienced especially when consecutive questions were being asked. The journey of a deaf and mute individual is one of resilience, innovation and advocacy. They have the same rights and opportunities as their hearing counterparts. This study could help restaurants save money by not employing sign-language interpreters.

People with speech and hearing impairment survived for so long with the assistance of their love ones. On their own, they use paper and pen when communicating. As the society progresses, deaf and mute have formed a community and learned to communicate with each other using non-verbal language called sign language. In the Philippines, we have an official sign language of the deaf known as the Filipino Sign Language (FSL). A web application was developed to interpret spoken and text inputs into FSL executed by a 3D avatar using speech recognition along with sentiment analysis in detecting and tracking human pose [1].

Visual sign language recognition (VSLR) is a complex area in computer vision. From the many models proposed by various Researchers, Vision – Based proposed models using Deep Learning Approaches showed significant improvement in recognition accuracy in sign language recognition [2]. A study conducted on real time recognition of American sign language capture signs using webcam to predict action demonstrated without any external devices used. The long short-term memory (LSTM) model was used to produce real time sign language detection and prediction flow. The study shows 99.35% accuracy which will allow the deaf and mute to communicate with the society more easily [3].

Hand gesture recognition is a technology that interprets human hand movements using algorithms and sensors, with applications in virtual reality (VR), augmented reality (AR), human-computer interaction (HCI), sign language interpretation, and robotics. A similar study was conducted proposing a technique which commands computer using six static and eight dynamic hand gestures results to 93.09% accuracy [4].

A study called SiTa: Sign Talker system accepts English and Filipino words or phrases then translates to American Sign Language (ASL) and FSL was developed using android based mobile application. The text analysis algorithm used is Knuth-Morris-Pratt Naïve algorithm that searches sign language animation stored in the application. Test results showed satisfaction on the overall performance of the system application by most participants [5].

Sign languages are visual languages using hand, face and body movements. A paper uses skeleton representations to focus on recognition of motion. Analysis of applicability of the pose estimation system to sign language recognition evaluates the failure cases of the recognition models [6]. A sign language recognition method based on a movement in-a-video detection scheme achieved an accuracy of 90.33% and 40% in classifying short and medium gestures, respectively compared with 69% and 43.7% achieved using other methods. The scheme is applied to extract unique spatial and temporal features for each gesture [7].

On the other hand, a device was developed to allow the deaf and mute to speak with the aid of a speaker and an LCD display. It utilizes wearable gloves with flex sensors GSM module and a lithium-ion rechargeable battery using Arduino Uno as controller [8].

There is a study on a total of 649 publications related to decision support and intelligent systems on sign language recognition (SLR) which shows the importance of incorporating intelligent solutions into the sign language recognition systems and reveals that perfect intelligent systems for sign language recognition are still an open problem [9].

A different approach was conducted using Technology Acceptance Model (TAM) to determine perceives use of ease of the McDonald's self-service kiosks in Cavite by the 110 respondents from the Federation of the Deaf. The results showed that the kiosks provide clear images of different menu items and helps them easily see their desired order. The respondents are looking forward to use more kiosks in the future [10].

Based on the survey conducted by the researchers from the Pinoy Deaf Rainbow Organization, the ten most essential sign words used for ordering food are "what," "hello," "please," "how much," "yes," "no," "dine-in," "take- out," and "thank you" and were used for the reference of the study.

The researchers aimed to design a device that uses neural networks to translate common ASL into text so that it can be used to assist in ordering food in a fast-food restaurant. This system allows users to accurately detect and translate common food ordering ASL into the text.

METHODOLOGY

A. Research Locale

The research settings/locale of the study was a fast- food restaurant; wherein the researchers focused on the ordering assistance for the deaf community.

B. Research Design

The study's research design was prototyping, allowing the researchers to produce the HandSpeak software for the prototype.

C. Respondents of the Study

The study's respondents were the Pinoy Deaf Rainbow; through this non-profit organization of the Deaf community, the researchers gathered the data needed for common words for the HandSpeak development.

This public group for deaf individual advocacy helps deaf individuals and creates a community for them; and three students from the tertiary level participated in the study who tested the HandSpeak Application.

- John Doe One, wherein the first participant is less knowledgeable in using sign language.
- John Doe Two, wherein the second participant is proficient in using sign language.
- John Doe three, wherein the third participant is also proficient in using sign language.

D. Research Instrument

The research instrument of the study was an online survey via Google form; this survey questionnaire was collected via electronic form through the Facebook pages of the Deaf Groups. In order to identify what is the common words uses of the deaf individual while purchasing in fast-food restaurant.

E. Statistical Treatment of Data

The statistical treatment of Data used in the study was the accuracy score; wherein it will calculate the accuracy level of the translation of every sign language set word in repeated testing.

$$\text{Accuracy Score} = \frac{\text{(number of correct translation)}}{\text{(total number of hand gestured performed)}}$$

Equation 1

The accuracy score in the equation (1) calculated by dividing by the number of correct translations by the total number of hand gestures performed by respondents on the set trials.

RESULTS AND DISCUSSION

Multiple angles and perspectives were collected by capturing recorded videos. Python libraries that were created from these frames such as landmarks and hand gestures were converted into NumPy array and created teaching the model to associate the particular landmarks to the intended meaning. Through these, the OpenCV enabled the real-time recognition. The used of pyttsx3 library enabled the system to produce spoken output to the matched sign language into word of phrase and tkinter library for the interface which made the system user-friendly. The software integrates Mediapipe and Tensorflow to recognize gesture key points and provide audio feedback. It combined visual and audio features.

Metrics used to assess the trained machine learning model such as Epoch Loss, Epoch Categorical Accuracy, Confusion Matrix, and real-world testing accuracy score.

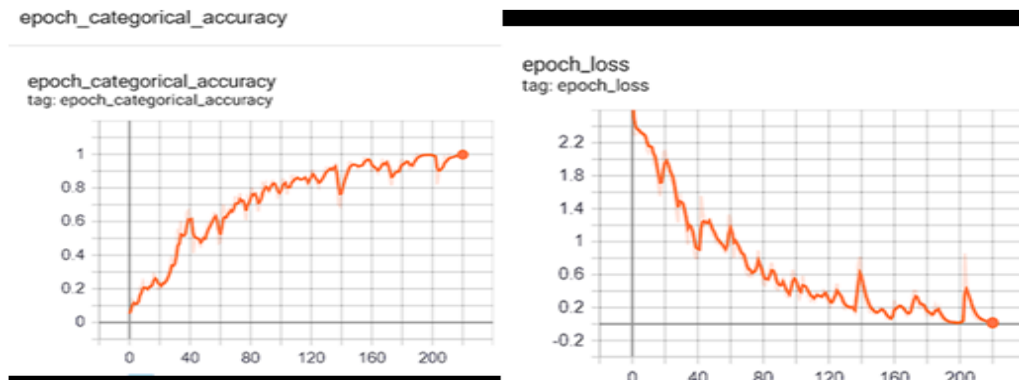

Fig. 1. Epoch Categorical Accuracy and Epoch Loss

In figure 1. Epoch Loss measures the model's error following each training cycle; smaller numbers signify better performance. Higher values indicate better accuracy.

Epoch Categorical Accuracy quantifies how frequently the model classifies data properly. The effectiveness of the model's learning and prediction depends on both metrics.

The model's epoch-categorical accuracy is displayed in a graph in Tensor Board, with the value determined at various training stages. About 99.78% of the accuracy is smoothed which indicates a strong general trend of high accuracy. At step 220 the actual accuracy value is 1, or 100%, signifying perfect categorization at that time. This figure was recorded five minutes and twenty-four seconds into training. In conclusion, the model performs to its highest level at step 220 during training, exhibiting extraordinarily high category accuracy. This indicates that at this stage of training, the model is extremely skilled at correctly classifying data items into the appropriate categories. The loss function's general trend is represented by the smoothed loss value of 0.01511, which has been averaged to lessen noise and improve the pattern's overall visibility. The model's loss value at step 220 (a specific stage of the training process) is 0.0105. 5 minutes and 24 seconds into the training session is when this value was recorded.

A value of 0.0105 was reached at step 220, indicating that the model consistently displays minimal loss values throughout the training procedure. This shows that, at this point in the training phase, the model's predictions and the actual values are closely aligned, showing effective learning and performance.

Multilabel Confusion Matrix Analysis

Evaluation of confusion matrices for each class to assess the performance of the model. It utilized a one-vs-all strategy for a multiclass problem in the context of this study.

Classes according to the label map

"Yes", "What", "Thank you", "Take-out", "Please", "No", "How Much", "Hello", "Food" and "Dine- In."

Each class's confusion matrix has the structure: [[True Negatives (TN), False Positives (FP)], [False Negatives (FN), True Positives (TP)]]

The following are the confusion matrices for each class:

'Yes' Class

True Negatives (TN): 12 instances correctly identified as not 'Yes'

False Positives (FP): 0 instances incorrectly identified as 'Yes'

False Negatives (FN): 0 instances incorrectly identified as not 'Yes'

True Positives (TP): 3 instances correctly identified as 'Yes'

'What' Class

True Negatives (TN): 14 instances correctly identified as not 'What'

False Positives (FP): 0 instances incorrectly identified as 'What'

False Negatives (FN): 0 instances incorrectly identified as not 'What'

True Positives (TP): 1 instance correctly identified as 'What'

'Thank you' Class

True Negatives (TN): 14 instances correctly identified as not 'Thank you'

False Positives (FP): 0 instances incorrectly identified as 'Thank you'

False Negatives (FN): 0 instances incorrectly identified as not 'Thank you'

True Positives (TP): 1 instance correctly identified as 'Thank You'
 And so on for every class.

Multiclass Confusion Matrix	
[[12,0],	[0,3]],
[[14,0],	[0,1]],
[[14,0],	[0,1]],
[[13,0],	[0,2]],
[[12,0],	[0,3]],
[[13,0],	[0,2]],
[[14,0],	[0,1]],
[[14,0],	[0,1]],
[[14,0],	[0,1]]],

Figure2. Confusion Matrix

In figure2; confusion matrices show that the model performed well, with no misclassifications for the data provided being observed.

The distribution of the classes in the dataset must be considered, though, the performance of the model might not be as reliable in cases where a class is underrepresented as the confusion matrix suggests.

Real World Testing

Table 1
 Accuracy Score of and Speak Trials

HANDSPEAK REAL WORLD TESTING									
WORDS	TEST 1	TRIALS	RESULT	TEST 2	TRIALS	RESULT	TEST 3	TRIALS	RESULT
HELLO	5	10	0.5	6	10	0.6	7	10	0.7
YES	5	10	0.5	5	10	0.5	9	10	0.9
NO	10	10	1	10	10	1	4	10	0.4
WHAT	5	10	0.5	9	10	0.9	6	10	0.6
HOW MUCH	6	10	0.6	6	10	0.6	3	10	0.3
THANKS	9	10	0.9	8	10	0.8	3	10	0.3
PLEASE	5	10	0.5	10	10	1	7	10	0.7
FOOD	5	10	0.5	5	10	0.5	10	10	1
DINE IN/ EAT IN	3	10	0.3	7	10	0.7	7	10	0.7
TAKE OUT	4	10	0.4	7	10	0.7	8	10	0.8

In Table 1; data given is a thorough evaluation of a sign language recognition system's performance over the course of three different test periods. In these tests, different expressions such "Hello," "Yes," "No," "What," "How Much," "Thanks," "Please," "Food," "Dine In/ Eat In," and "Take Out" were put through ten trials each, with their identification accuracies were recorded.

The data for a sign language recognition system demonstrate a discrepancy between training and real-world testing, with training indicating nearly perfect performance and testing show unpredictability. Key words including "No," "Thank You," and "How Much" showed declines in recognition, in contrast to "Food" and "Take Out" which sought an improvement. Differences in sign execution, ambient variables, and restrictions on the training data, among other things, could all be contributing factors to the inconsistent results.

According to website of Hasty (2023), having the accuracy >0.9 it results and excellent score, while the accuracy >0.7 means also a good one while, lower than <0.7 , means the accuracy was poor. The more the data gets higher correct prediction, the higher accuracy score will be collected.

CONCLUSION AND RECOMMENDATION

Conclusion

The development and testing of a sign language recognition software targeted at enhancing communication accessibility for those who are deaf or hard of hearing are highlighted by the study's combined findings, which come to this conclusion.

To track and understand hand, facial, and body motions in real time, translate them into spoken output, and enable continuous communication, the program combines computer vision techniques, machine learning algorithms, and user-friendly interfaces.

The study emphasized the implementation of the software HandSpeak, which enhanced the ordering process for deaf individuals in fast-food settings. The software utilized image processing tools, records high-definition video input, detects sign gestures, and displays real-time feedback on a monitor. Additionally, it included audio features that translate text inputs into audible speech and enable conversation through a speaker.

The study also explored the system's training to convert typical fast-food words into American Sign Language (ASL). The model's effectiveness was evaluated using measures like Epoch Loss, Epoch Categorical Accuracy, and Confusion Matrix. The results demonstrated efficient learning and performance with excellent accuracy and low loss values throughout training. Real-world testing, however, revealed differences between training and testing, indicating possible difficulties with recognition accuracy caused by changes in sign execution and other circumstances.

The integration of visual and audio features, the training of the system to translate fast-food orders into ASL, and the development of a sign language recognition application are all topics covered in this study. It highlights how computer vision, machine learning, and user-friendly interfaces may help people who are deaf or hard of hearing communicate more effectively. However, more investigation is required to overcome the reported inconsistencies and boost recognition accuracy in a variety of settings.

Using a camera with a higher frame rate, such as 60 frames per second, will not result in any observable improvements in the output when the code or software is hardcoded to process video input at 30 frames per second. The application will discard Every other frame, maintaining the same effective frame rate of 30 frames per second. Therefore, in this particular circumstance, using a faster frame-rate camera would not offer any further benefits regarding sign language detection.

Recommendation

It is crucial to remember that the method is only intended to help and might only partially eliminate all cases of misunderstanding. More study and advancements are needed to handle the ASL's complexity and guarantee the system's accuracy and usefulness in practical situations. The study shows how motion detection and neural network technology can improve deaf people's communication ability, especially in restaurant situations.

This technology can help people who are deaf communicate better, overcome language hurdles, and have a more inclusive eating experience. Additionally, it provides a more affordable option than hiring sign language interpreters, saving money while maintaining the standard of care for consumers who are deaf.

REFERENCES

- [1] A. A. Alberto, Et al, "Senyas: A 3D Animated Filipino Sign Language Interpreter Using Speech Recognition", 2022 .
- [2] R. Rastgoo, K. Kiani, & S. Escalera, "Sign language recognition: A deep survey", expert systems with applications, vol 164, 2021, 113794.
- [3] Abdulhamied, R. M., Nasr, M. M., and Abdulkader, S. N., "Real-time recognition of American sign language using a long-short-term memory neural network and hand detection", 2023.
- [4] Hussain, S., et al, "Hand gesture recognition using deep learning", IEEE, DOI: 10.1109/ISOCC.2017.8368821, 2017.
- [5] A. M. Masbate. Et al, "Text to English and Text to Filipino Sign Language Translator: An Android-based Mobile Application with Text Analysis Using Knuth-Morris-Pratt Naive Algorithm", 2020, N.D.
- [6] R. Kate, Et al, "Hand gesture recognition system using holistic mediapipe", International Research Journal of Engineering and Technology, 2022.
- [7] M. Young, The Technical Writer's Handbook. Mill Valley, CA: University Science, 1989.
- [8] Patwary, A., Zaohar, A., Sornaly, A., Khan, R. "Speaking System for Deaf and Mute People with Flex Sensor" , 2022
- [9] I. Adenyanju, Et al, "Machine learning methods for sign language recognition: A critical review and analysis, intelligent systems with applications",2021, [HTTPS://DOI.ORG/10.1016/J.ISWA.2021.200056](https://doi.org/10.1016/j.iswa.2021.200056)
- [10] M. Peteza, D, C, Lopez, M. Senorin, "Kiosks of McDonald's in Cavite towards friendly order taking process for Persons with Deaf Disability, International Journal of Management and Commerce Innovations, ISSN 2348-7585 .Vol. 9, Issue 2, pp: (621-631), Month: October 2021

ACCEPTABILITY OF HOME MADE BLUE TERNATE ICE CREAM

Ma. Lee D. de los Reyes

INTRODUCTION

An innovation of a product was made using blue ternate flowers that are suitable for the taste of some people. The study focuses on product development using the petals of blue ternate (butterfly pea) as an additional ingredient in ice cream to make it more healthier to the children and to the adult as well. Blue ternate flower, *Clitoria ternatea*, has traditionally been used as a vegetable in cooking and can be mixed with other vegetables in salad dishes, which is why blue ternate ice cream was developed as a traditional ice cream and is uniquely characterized by the milk.

OBJECTIVES

The main objective of this study was to identify the ingredients, tools, and equipment used in the utilization of homemade blue ternate ice cream. Determine the step-by-step procedure for preparing homemade blue ternate ice cream; to conduct a pilot product testing of blue ternate ice cream, to determine the safety measures and shelf life of the above-mentioned food products; and to provide proper packaging suited to the product.

METHODS

Researchers used experimental methods to develop new foods, create new recipes and uncover the nutritional effects of homemade blue ternate ice cream. The researcher used a survey questionnaire to gather data from a specific group of individuals, students of Bachelor of Science in Industrial Technology major in Food Technology and faculty in food technology and HRM professor.

RESULTS

The overall assessment in developing Homemade Blue ternate Ice Cream researcher utilized **the ingredients** of Blue ternate petals, water, sugar, cassava flour, coconut milk, powdered milk, all-purpose cream, condensed milk, and eggs. **The tools and Equipment** used by the researcher were casserole pot, food processor, ice cream cooler, ice cream mixer/machine, ice cream tube gallon, measuring cup, mixing paddle, planetary mixer, plastic container, portioning bowl, scooper, stove, and wooden spoon. **The step-by-step procedure for making homemade blue ternate ice cream** is to boil water and sugar and dissolve cassava flour into the mixture. Put the powdered milk, coconut milk, all-purpose cream, and condensed milk into the container. Put the cassava mixture in a separate container, add the combined mixture, and blend thoroughly. Place two ice cream tubes into an ice cream cooler surrounded by ice and salt. Add ground blue ternate petals for flavoring. Stirring occasionally until the ice cream forms. **The pilot product testing of homemade blue ternate ice cream**, conducted several tests to achieve the desired taste of the ice cream. **The safety measure for homemade blue ternate ice cream**, was to ensure that all components were fresh and not expired before mixing all the ingredients, and to avoid infection, clean the space during preparation and sterilize all the tools and equipment used in preparation and packing. **The homemade blue ternate ice cream has a shelf life** of 7 days at freezing cold and must be sealed. **The sensory evaluation**, both students and professors rated the homemade blue ternate ice cream as Acceptable since it was distinctive in terms of taste, smell, and appearance.

CONCLUSION

The sensory evaluation, the students and faculty evaluated the homemade blue ternate ice cream. The respondents think it is unique in terms of its taste, smell, and appearance, which makes the homemade blue ternate ice cream Acceptable.

The safety measure for homemade blue ternate ice cream, was to ensure that all components were fresh, to avoid contamination. The researcher assured that all the tools and containers used in preparation and packaging were sanitized. The shelf life of homemade blue ternate ice cream is 7 days at freezing cold and must be sealed.

“BABEL”: A LANGUAGE TRANSLATOR MOBILE-BASED APPLICATION*Catherine D. Dumpit***INTRODUCTION**

The Philippine education supports effective communication and using it as a key to sustain an interconnected world, making the foreign language skills the ultimate tool and skill for the 21st century (SteinSmith K. 2017). The Department of Education (DepEd) offers the Special Program in Foreign Language (SPFL) in public secondary schools nationwide, that will help the learners to develop their skills in learning, writing, reading and speaking that are fundamentals in acquiring their competency in second foreign language.

BABEL provides language translation from one foreign language to another via speech and text. The mobile application will also provide basic information and introduce our learners to popular tourist destinations, food delicacies, landscapes, festivals, and cultural attractions from the selected countries. The application will help our end users learn the basic foreign language and use the language properly. The languages included in this translator mobile based application are the languages used in foreign language classes in San Pedro Relocation Center National High School Langgam Campus, and these are: Mandarin(China), Nihongo (Japanese), Hangul(Korean), English, Filipino. The Babel mobile application offers various translation modes such as: text-to-text, speech-to-text, text-to-speech, speech-to-speech.

The purpose of this study was to developed a user-friendly language translator mobile-based application for San Pedro Relocation Center National High School. It is developed to provide foreign language students an educational tool that will help them to refine their learnings in their foreign language class. The application with its user-friendly interface is designed to be an informative as possible allowing the student gain more knowledge in foreign language.

METHODOLOGY

This study used descriptive-developmental type of research in developing the application. The research instrument used in the study were survey questionnaire to describe the ideas and point of views of the teachers, students and IT experts. Agile methodology is used in the development of the application and evaluated using ISO25010, to meet the standard quality product. The researcher utilized purposive sampling method consists of 10 teachers, 60 students and 5 IT experts. The gathered data from the survey questionnaire were classified, tallied and encoded to determine the perception of the respondents in the developed application using percentage and frequency for the number of respondents and weighted mean for the to analyze the level of respondents assessments.

RESULTS AND DISCUSSION

1. What are the features of developed BABEL - Mobile-Based Application?

The mobile application is an interactive application that can translate text to text, speech to text, the history of the translated words. It runs on the Android application system. It will also provide basic information and introduce our learners to popular tourist destinations, food delicacies, landscapes, festivals, and cultural attractions from the selected countries.

This system focuses on guiding our learners in learning foreign languages. This includes countries China, Japan, Korean, English, and the Philippines. This system also provides a feature called Phrasebook, where the mobile application provides commonly used phrases used in

restaurants, phrases used in schools, for survival or directions, numbers, and family members. The mobile application also offers general information on tourist attractions, delicacies, and beaches in various countries that are included in the mobile application.

2. How do the respondents assess the BABEL - Mobile-Based Application?

Criteria	Weighted Mean	Adjectival Meaning
Performance Effectiveness	4.36	Very Acceptable
Performance Efficiency	4.32	Very Acceptable
User Interface Design	4.37	Very Acceptable
Flexibility	4.29	Very Acceptable
Accuracy	4.25	Very Acceptable
Security	4.23	Very Acceptable
Help Options	4.24	Very Acceptable

The assessment of Babel : A Language Translator Mobile-based Application was very acceptable in terms of performance effectiveness, performance efficiency, user interface design, flexibility, accuracy, security and help options as assessed by the respondents.

3. Based on the findings, what enhancement may be proposed?

- The respondents recommend to improve its flexibility so that users can run it on different platforms or environment.
- The respondents recommend to enhance the color combinations of the mobile design application
- The respondents recommend to enhance the security features of the application

The feedback from respondents underscores the importance of improve its flexibility so that it can run on different platforms. Visually appealing design applications ultimately enrich the creative process for users and security measures can further strengthen user trust and confidence in the application. Implementing such improvements will undoubtedly enhance user satisfaction and elevate the app's overall usability and effectiveness.

CONCLUSION

BABEL : A Language Translator Mobile-based Application was very acceptable and could be utilized as supplementary educational tool for learning foreign language.

RECOMMENDATIONS

1. Faculty handling foreign language are encouraged to utilize application as supplemental aid in the presentation and carrying out the lessons.
2. Conduct training sessions with the teachers and students.
3. For the future researchers, the application needs further evaluation to elicit feedback and enhancement.

REFERENCES

- Abdullaev (2021). SECOND LANGUAGE LEARNING. [https://api.scienceweb.uz/storage/publication_file_s/626/799/618f765a8fcac___Abdullaev%20Z%20maqola.p df](https://api.scienceweb.uz/storage/publication_file_s/626/799/618f765a8fcac___Abdullaev%20Z%20maqola.pdf)
- Absalon et al. (2019, April 1). Barriers of Language Communication: Its effects in the academic performance of Grade 12 General Academic Strand students of Bestlink College of the Philippines. <https://ojs.aaresearchindex.com/index.php/aasgbcjpmra/article/view/1150>
- Arbes et al. (2019). Tagalog text-to-braille translator tactile story board with 3D printing. <https://doi.org/10.1088/1757-899x/482/1/012023>
- Fastovets (2021). Developing mobile software for foreign language learning. https://www.researchgate.net/publication/357138284_Developing_mobile_software_for_foreign_language_learning
- Department of Education (2017). DepEd enhances learners' foreign language skills through Special Program in Foreign Language. <https://www.deped.gov.ph/2017/02/20/deped-enhances-learners-foreign-language-ski>

C++ QUIZ APPLICATION

*Catherine D. Dumpit
Richard Carl G. Alfaro*

INTRODUCTION

Android-based app development Quiz applications are mostly used by students and learners to prepare for various examinations using smartphones and tablets in their hands. One of the main goals is to make it easier for students to learn, gain, and improve their knowledge and abilities.

This mobile application is about developing a C++ Quiz Application that contains basic to intermediate C++ programming questions on a mobile device. The program was created by researchers with the goal of making it simpler to use, preparing users for exams and tests, and enabling them to take quick quizzes on Android devices.

Problem Statement

This study aims to develop C++ Quiz Application for students of Eulogio “Amang” Rodriguez Institute of Science and Technology – Cavite Campus.

1. Which programming language is the hardest to learn?
 - 1.1 Python
 - 1.2 C Language
 - 1.3 C++ Language
2. What are the features of the developed C++ Quiz Application?
3. How do the IT students and IT experts assess the C++ Quiz App in terms of:
 - 2.1 Performance Effectiveness;
 - 2.2 Performance Efficiency;
 - 2.3 User Interface Design;
 - 2.4 Flexibility;
 - 2.5 Accuracy; 2.6 Security options; and
 - 2.7 Help Options?

METHODOLOGY

Research Design

The researcher used descriptive-developmental method type of research in developing the C++ Quiz Application. According to Jackson (2009), the descriptive method of research, participants answer questions administered through interviews and questions. After participants answer the questions, researchers describe the responses collected.

Participants and Sampling Plan

A total of one-hundred fourteen (114) student-respondents were utilized coming from three different courses namely BS Computer Science and BS Information Technology through purposive quota sampling and ten (10) IT experts. The research instruments used in gathering the data were questionnaire and interview.

Instrumentation

The research instruments used in gathering the data were questionnaire and interview.

The Likert scale was used to determine the computed value on the effectiveness of the E-Instructional Material, they were rated and interpreted as follows:

Scale	Range	Interpretation	Symbol
5	4.20-5.00	Strongly Acceptable	(SA)
4	3.40-4.19	Very Acceptable	(VA)
3	2.60-3.39	Acceptable	(A)
2	1.80-2.59	Less Acceptable	(LA)
1	1.00-1.79	Not Acceptable	(NA)

RESULTS AND DISCUSSION

1. Which programming language is the hardest to learn?

Table 1
Programming Language

Subject	Frequency	Percentage
Python	20	17.54
C Language	36	31.58
C++ Language	58	50.88

2. What are the features of the developed C++ Quiz Application?

Download and installation

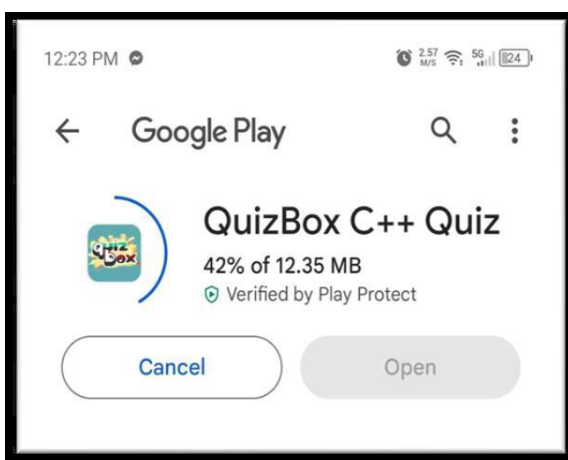

Log In Page

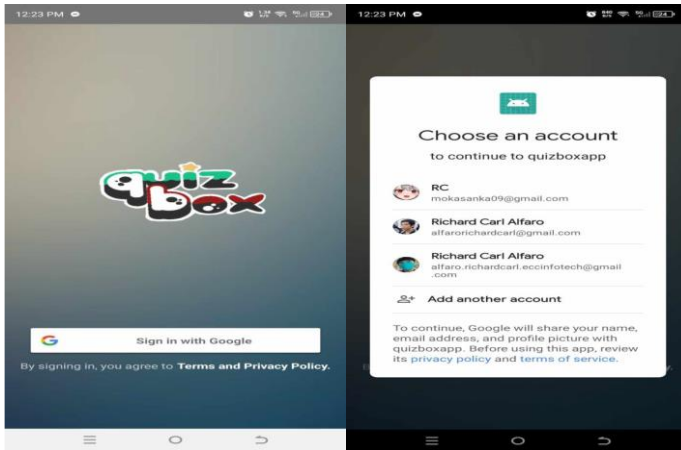

Quiz Topic Page

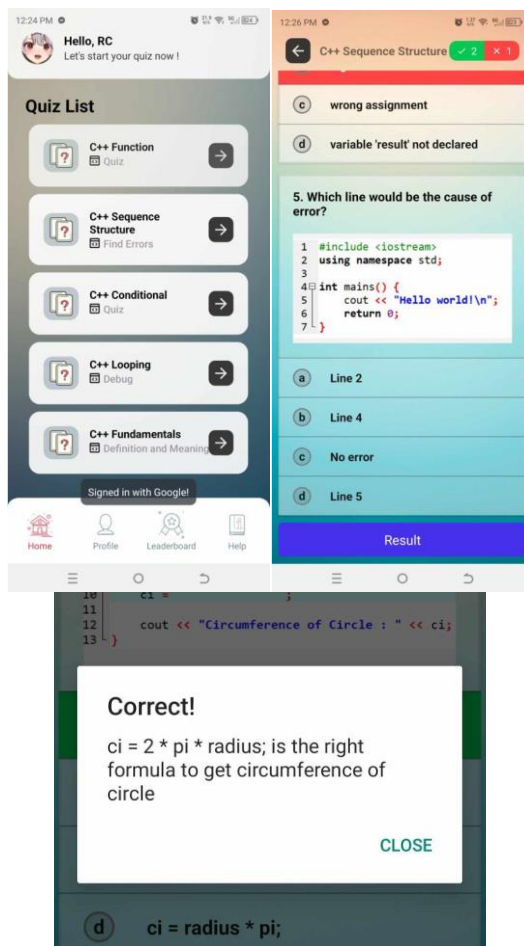

Explanation Popup when correct answer is chosen

Help Page

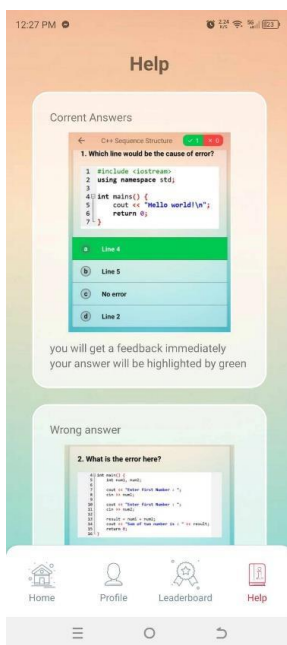

3. How do the IT Experts and students assess the C++ Quiz App in terms of:

Table 2
Assessments of IT Experts and Students

Criteria	Weighted Mean		Combined Weighted Mean	Adjectival Meaning
	IT Expert	Students		
Performance Effectiveness	4.53	4.11	4.14	Very Acceptable
Performance Efficiency	4.60	4.11	4.15	Very Acceptable
User Interface Design	4.53	4.17	4.20	Very Acceptable
Flexibility	4.53	4.22	4.24	Very Acceptable
Accuracy	4.16	4.16	4.18	Very Acceptable
Security	4.13	4.13	4.16	Very Acceptable
Help Options	4.22	4.22	4.25	Very Acceptable

As presented in the table, the respondents rated all variables as very acceptable with combined weighted mean values of: 4.14 as to performance effectiveness; 4.15 as to performance efficiency; 4.20 as to user interface design; 4.24 as to flexibility; 4.18 as to accuracy; 4.16 as to security and 4.25 as to help options.

CONCLUSIONS

1. Most students select C++ as the hardest programming language to learn
2. The salient features of the C++ Quiz Application are user-friendly and flexibility.
3. The assessment of C++ Quiz Application was very acceptable as assessed by the two groups of respondents.

RECOMMENDATIONS

1. C++ Quiz Applications need to be able to perform all task that may be desired in the future like output generating reports to give them results of the quizzes, efficient back-up and provides a roles and policies for the users.
2. Faculty handling C++ programming language are encouraged to utilize the C++ Quiz Application as supplemental aid in the presentation and carrying out the lessons.
3. For other researchers, the C++ Quiz Application needs further evaluation to elicit feedbacks and enhancement.

REFERENCES

- Ameen (2021). Android Quiz Application Based on Face Recognition: Recent Advances in Computer Science and Communications (Formerly: Recent Patents on Computer Science), Volume 14, Number 5, 2021, pp. 1573-1581(9) Retrieved from : <https://www.ingentaconnect.com/content/ben/rascs/2021/00000014/00000005/art00029>. Date Retrieved: January 29, 2022
- Behamanush (2018). A Project on Online MCQ Quiz Application Retrieved from: https://www.researchgate.net/publication/336115534_A_Project_on_Online_MCQ_Quiz_Application. Date Retrieved: January 29, 2022. DOI:10.13140/RG.2.2.10583.83369

GMA CIVIL REGISTRAR ONLINE TRANSACTION SYSTEM

Rowee M. Marfil

INTRODUCTION

The growth in mobile phone industry and mobile application has been one of the important technology innovations in computing in this generation. This innovation supports different aspects of daily living. In the fast-paced advancement of computing devices known as “digital-era”, provides revolutionized and a variety of application and integration to different sectors from communication, entertainment, education, security, business operations and government services. This “digital era” become indispensable equipment’s that gives the end-users a more efficient, effective, reliable and accessible services for a wide range of application.

The innovative solutions of this rapid technological evolution change traditional delivery of services including government services. However, Municipality of government agencies faced challenges in adopting digital solutions and innovations for their services, this leads to inefficiency of transaction, long waiting time and bureaucratic hurdles for the people, this was also stated in the study of Abdullah et al. (2022), that the organizations often face challenges, such as the need to keep pace with technological developments to achieve high performance and manage their business efficiently and free from time-consuming procedures. Implementation of e-government in the country has been in the planned of the government, thus Urbina and Abe (2017) in their study, they investigate the adoption of e-government in the country, However, in developing countries like the Philippines, citizens face significant challenges in adopting e-government due to disparities in socio-demographics, access to ICTs, Internet use patterns, and awareness of available services.

Government services could be enhanced through e-government. According to Al-Hashmi et al. (2012), the national e-government projects in the Philippines are still moving forward. There needs to be more empirical research on local e-governments. The E-Government Masterplan (EGMP) recognized the significant role that ICT plays in promoting open and transparent government and the provision of adequate public services based on assessment and with the intention to operationalize the e-Government emphasis of the Philippine Digital Strategy. (Department of Information and Communication Technology, 2014). Magno (2018) stated that incorporation of E-government services is a vital lever in growth in the Philippines, this innovative initiative has been taken to improve the public service delivery.

Civil registries, which are essential for various legal and administrative purposes, faces challenges and issues. The limited accessibility of civil registry services, especially for individuals residing in remote areas or those with mobility impairments. Additionally, the lack of online platform for requesting and obtaining vital documents. In the study of Villena et al. (2021) they examine the various Civil Registry Document (birth certificates, marriage certificates, certificates of no marriage, and death certificates etc.) acquisition methods. They suggested an immediate, electronic, paperless, and more expedient alternative to the current procedures for obtaining Civil Registry Documents. Moreover, physical distance and transportation challenges can hinder access to these essential services. Thus, these traditional methods, opted to involve in-person visits and lengthy paperwork, doing manual-procedures are likely to cause errors, delays and inconvenient.

The development of the GMA Civil Registrar Online Transaction System represents a significant leap toward modernizing public services. Guided by Jones et al.'s (2004) theoretical framework, which emphasizes the relationship between citizens' needs and their engagement

with government services, this research explores the application's ability to meet user demands efficiently. It addresses problems, in need for innovative solutions that leverage technology to streamline government processes and improve citizen experience making them faster, more reliable, and accessible. Mobile applications, in particular, offer to address the challenges faced by citizens when accessing essential civil registry service. By digitizing the request and issuance of documents such as obtaining certificates for birth, marriage, death, and CENOMAR, as well as booking appointments for other related services., these applications can significantly reduce wait times, minimize paperwork, and enhance transparency an application for the user to conduct transactions from the comfort of their homes.

METHODOLOGY

This study used the descriptive developmental research based on Heffner (2011), developmental method, described as the methodical investigation of developing, manufacturing, and evaluating educational processes, goods, and programs that must satisfy the standards for efficacy and internal consistency. The purpose of the system was to design online transaction system, thru a mobile application system for Municipality of GMA Civil Registrar, that facilitates and address the challenges by digitizing all services of the office. For getting relevant information, the researcher collects data and demographic profile (age, gender and profession) from Walk-in Clients and Municipal Civil Registry Office (MCRO) Staff, using the convenience sampling technique and for IT Experts, using purposive sampling technique. In the development of the application, Agile Methodology approach was used, this approach to software development interleaves program specification, design, and implementation. This study evaluates the application for its functionality, reliability, usability, efficiency, maintainability, and portability, these criteria are according to ISO 25010. ISO 25020 is an international standard that defines a framework for evaluating the quality of software and systems. It provides a structured way to define, measure, and evaluate software quality based on the above-mentioned criteria. For treating the data, frequency, percentage, rank, weighted mean is used, and t-test to determine the difference of the assessment to the system among the respondents in terms of the above-mentioned variables.

RESULTS AND DISCUSSION

Table 1
Summary of Assessment on the Application

Variables	Weighted Mean	Interpretation	Rank
Functionality	4.64	Strongly Acceptable	2.5
Reliability	4.58	Strongly Acceptable	5
Usability	4.62	Strongly Acceptable	4
Efficiency	4.56	Strongly Acceptable	6
Maintainability	4.64	Strongly Acceptable	2.5
Portability	4.67	Strongly Acceptable	1
Grand Mean	4.62	Strongly Acceptable	

Table 1 shows the summary of assessment of the evaluators on the mobile application were Portability with weighted mean of 4.67; Functionality and Maintainability with weighted mean of 4.64; Usability with weighted mean of 4.62; Reliability with weighted mean of 4.58 and Efficiency with weighted mean of 4.56 and all are Strongly Acceptable for its interpretation. The assessment illustrated that the mobile application has a high level of acceptability from the end-users. Kim (2021) stated that E-government platform offers features that may provide customers

with what they want, ranging from making online services more accessible to connecting with other agencies. This will aid in the development of "citizen-centric" services that prioritize improving access and providing critical services on a single platform.

Table 2
Difference on the Assessments of the Respondents when Grouped According to Age

Variables	p-Value	Hypothesis	Interpretation
Functionality	0.963	Accept Ho	Not Significant
Reliability	0.775	Accept Ho	Not Significant
Usability	0.625	Accept Ho	Not Significant
Efficiency	0.682	Accept Ho	Not Significant
Maintainability	0.214	Accept Ho	Not Significant
Portability	0.822	Accept Ho	Not Significant

Note: Level of significance at 0.05

Table 2 shows the difference on the assessments of the respondents on the application when grouped according to age. Data shows that there was no significant difference between the assessments of the evaluators as to functionality, reliability, usability, efficiency, maintainability, and portability supported by computed p-value of 0.963, 0.775, 0.625, 0.682, 0.214 and 0.822. Thus, the null hypotheses were all accepted.

Table 3
Difference on the Assessments of the Respondents when Grouped According to Gender

Variables	p-Value	Hypothesis	Interpretation
Functionality	0.599	Accept Ho	Not Significant
Reliability	0.791	Accept Ho	Not Significant
Usability	0.880	Accept Ho	Not Significant
Efficiency	0.505	Accept Ho	Not Significant
Maintainability	0.044	Accept Ho	Not Significant
Portability	0.459	Accept Ho	Not Significant

Note: Level of significance at 0.05

Table 3 shows the difference on the assessments of the respondents on the application when grouped according to gender. Data revealed that there was no significant difference between the assessments of the respondents on the application as to functionality, reliability, usability, efficiency and portability supported by computed p-value of 0.599, 0.791, 0.880, 0.505 and 0.459. Thus, the null hypotheses were accepted. Meanwhile, the p-value for maintainability was 0.044 which is less than the level of significance 0.05 the null hypothesis was rejected. Thus, there was significant difference on the assessments of the respondents as to application's maintainability.

Table 4
Difference on the Assessments of the Respondents when Grouped According to Profession

Variables	p-Value	Hypothesis	Interpretation
Functionality	0.772	Accept Ho	Not Significant
Reliability	0.319	Accept Ho	Not Significant
Usability	0.895	Accept Ho	Not Significant
Efficiency	0.941	Accept Ho	Not Significant
Maintainability	0.219	Accept Ho	Not Significant
Portability	0.903	Accept Ho	Not Significant

Table 4 shows the difference on the assessments of the respondents on the application when grouped according to profession. Data revealed that there was no significant difference between the assessments of the respondents on the application as to functionality, reliability, usability, efficiency, maintainability, and portability supported by computed p-value of 0.772, 0.319, 0.895, 0.941, 0.219 and 0.903. Thus, the null hypotheses were accepted.

RECOMMENDATION

Findings show a significant difference in the evaluation of the respondents for the variable maintainability when grouped by gender, the system recommends for improvements that focus on refining the mobile application maintainability features to ensure consistency and address the challenges faced by the clients. Even there are no significant differences on the respondent's assessment when grouped by age and profession, the researchers highly recommend to have a continuous evaluation and updates to maintain the strong acceptability of the application on the abovementioned variables.

Additionally, to improve the accessibility of the system, it is recommended to have an IOS version to facilitate the expansion of the platform devices. Moreover, it is highly recommended to provide MCRO staff training sessions on the use of the mobile application to maximize its benefits that will ensure the usability and satisfaction among the end-users. Furthermore, an integration with other E-government services to the mobile application for providing a more comprehensive services if applicable.

REFERENCES**A. BOOKS**

- Al-Hashmi, A., Suresha, A., & Darem, J. (2012). Maturity Assessment of Local E-government Websites in the Philippines.
- Reddick, C., & Norris, D. F. (2013) "E-participation in local governments," *Transform. Gov. People, Process Policy*, vol. 7, no. 4, pp. 453–476.

B. JOURNALS / PERIODICALS

- Abdullah, F. M., Mohammed, A. A., Maatuk, A. M., & Elberkawi, E. K. (2022). Application of Electronic Management System in Governmental Institutions: An Empirical Study on the Libyan Civil Registration. In *Proceedings of the Second International Conference on Data Science, E-Learning and Information Systems (DATA '19)*. Association for Computing Machinery, New York, NY, USA, Article 19, 1–5. Retrieved from <https://doi.org/10.1145>
- Bajar, J. (2021). E-Government in the Philippines: An Assessment. Retrieved from <https://paperscom/sol3>
- Balahadia, F., Molino, W., Bawica, J., Juanatas, I., Balmeo, H., & Ballera, M. (2017). E-Participation: Community Involvement Level Related to Different Services of Local Government Unit Officials. *International Journal of Computing Sciences Research*, 1(2), 10-20. Retrieved from stepacademic.net/ijcsr
- Bringula, R., Oliva, F., Vale, M. A., De La Serna, D. J. & Napolis, J. (2019). Towards the Development of E-Barangay Mobile Application. Retrieved from <https://doi.org/10.1145>
- Celeste, J., & Caelia, M. (2021). Civil Registration Awareness, Compliance, Purpose, and Challenges Among Municipal Residents in the Philippines. Retrieved from <https://scholar.google.com/scholar>
- Chen, J., Zhou, Q., & Zhang, T. (2022). A Novel Block Chain Method for Urban Digitization Governance in Birth Registration Field: A Case Study. Retrieved from <https://www.mdpi.com/1660-4601>
- Gupta, K.P., Bhaskar, P. and Singh, S. (2017), "Prioritization of factors influencing employee adoption of e-government using the analytic hierarchy process", *Journal of Systems and Information Technology*, Vol. 19 No. 1/2, pp. 116- Retrieved from <https://doi.org/10.1108/JSIT-04-2017-0028>
- Magno, Francisco A. (2017). "E-Government and Philippine Development" *Journal of Asia-Pacific Studies* (Waseda University). Retrieved from <https://www.jstage.jst.go.jp/article>
- Pasco, R., & Ona, S. (2017) Enabling e-Government in the Philippines: Uncovering Gaps and Opportunities in Policy Development. Retrieved <https://www.dlsu.edu.ph/wp-content>
- Prakoso, C. T. (2022). Digital Government Stage Evaluation in Population and Civil Registry Office (Disdukcapil) of Kutai Kartanegara Regency. Retrieved from <http://samarinda.lan/jba>

Ragani, S., Rompis, A. E., Hapsari, S., & Adikancana, D. (2021) Population and Civil Registration Service of Bandar Lampung City's Digital Bureaucratic System in Realizing an Effective and Efficient Government. Retrieved from <https://doaj.org/article>

Villena, L. R., Shiang, R., & Wei-Jung (2021), Analysis on Acquisition of Philippine Civil Registry Documents and Inclination Towards Paperless E-Government. IOP Conference Series: Materials Science and Engineering. Retrieved from <https://www.researchgate.net/publication>

C. THESES / DISSERTATIONS

Capistrano, E. P., PhD. (2019). Determining e-Government Trust: An Information Systems Success Model Approach to the Philippines' Government Service Insurance System (GSIS), the Social Security System (SSS), and the Bureau of Internal Revenue (BIR). University of The Philippines. Retrieved from <https://www.bsp.gov.ph>

Castillo, A.F., Diokno-Sicat, C.J., & Maddawin, R. B. (2020). Philippine Local Government Public Expenditure Review: A Survey of National Government Local Government Support Programs. Retrieved from <https://pidswebs.pids.gov.ph>

Domingo, J., & Rufino, G. (2021) A Framework in Developing a Citizen-Centered Smart City Mobile Application as a Platform for Digital Participation in Iloilo City. Retrieved from <https://www.researchgate.net/publication>

Khalid, S. A., & Lavilles, R. Q. (2019). Maturity Assessment of Local E- government Websites in the Philippines. Mindanao State University – Main, Marawi City. Retrieved from <https://www.sciencedirect.com/science>

Kim, K. (2020). Enhancing New York City's Online Service Capacity: Citizen-Centric Service Experience. Columbia University. Retrieved from <https://academiccommons.columbia.edu/doi>

Urbina, A. U., & Abe, N.(2017). Citizen-centric Perspective on the Adoption of E-Government in the Philippines, Vol. 15 No. 2. Retrieved from <https://academic-publishing.org/index.php>

ON QUARTER SQUARE SEQUENCE

Ramil L. Borres – Enrique Olanan and Associates
Rodora T. Oliveros – Eulogio “Amang” Rodriguez Institute of Science and Technology

INTRODUCTION

Mathematics is often most engaging when it takes the form of a puzzle, and this is particularly true in the study of sequences. This research delves into the concept of quarter squares—a sequence formed by repeatedly dividing a number into quarters. Quarter squares, with their unique properties, arise naturally in various mathematical contexts, including number theory, geometry, and cryptography. Utilizing descriptive and expository research methods, this study systematically explores the historical development, mathematical significance, and diverse applications of quarter squares. The findings highlight how understanding such sequences not only enhances problem-solving skills but also offers valuable insights into real-life phenomena, demonstrating the fascinating interplay between abstract mathematical concepts and practical applications.

The purpose of this study is to explore and provide detailed proofs regarding the quarter square sequence, examining its properties and relationships with other integer sequences. Specifically, the study aims to answer the following questions:

1. What is the quarter square sequence, and how is it generated?
2. What are the fundamental properties of the quarter square sequence?
3. How is the quarter square sequence related to triangular numbers, square numbers, oblong numbers, and the prime spiral?

Additionally, this research will investigate various applications of the quarter square sequence, including:

- Its – role in the square spiral of nonnegative integers.
- Determining the maximum product of two nonnegative integers whose sum is n .
- Calculating the maximum number of pieces formed by n slices of parallel or perpendicular lines.
- Identifying the number of nonempty subsets of $S=\{1,2,3,\dots\}$ containing exactly one odd and one even number.
- Finding the number of ways to represent all integers in the interval $[3,n+1]$ as the sum of two distinct natural numbers.
- Counting the number of lattice points in various geometric configurations.

METHODS

This study utilized descriptive and expository research methods to analyze the quarter square sequence and its properties. The descriptive method documented the sequence's generation, mathematical characteristics, and connections to other integer sequences, such as triangular and square numbers. In contrast, the expository method clarified complex concepts,

illustrating practical applications like determining the maximum product of two nonnegative integers whose sum is n and counting nonempty subsets containing one odd and one even number. By combining these methods, the study provided a comprehensive yet accessible exploration of the quarter square sequence, enhancing understanding of its mathematical significance and applications.

RESULTS AND DISCUSSION

The study focused on the quarter square sequence, yielding several significant results that address the specified problems. First, it established that for a square with a non-negative integer side n , the quarter of its area, rounded to the nearest integer, is defined as a quarter square, denoted by Q_n . This relationship highlights how the quarter square is derived from the area of a square, providing a tangible link between geometry and number theory.

The quarter square Q_n can be expressed mathematically as the product of the floor and ceiling of $\frac{n}{2}$, symbolically represented as $Q_n = \left\lfloor \frac{n}{2} \right\rfloor \cdot \left\lceil \frac{n}{2} \right\rceil$. This formulation underscores the mathematical structure of quarter squares and allows for easy computation. Several additional formulas were derived to determine the n th quarter square, including recursive relationships and piecewise functions, which facilitate the generation of quarter squares in a systematic manner.

Furthermore, the study established relationships between quarter squares and other well-known sequences. For instance, it was found that the quarter square Q_n is related to the triangular number T_n by the formula $Q_n = T_{n-1} + T_{n-2}$. This connection not only enriches the understanding of quarter squares but also situates them within the broader context of integer sequences.

The results also explored practical applications of quarter squares. Notably, quarter square numbers represent the maximum product of two nonnegative integers whose sum is n . Additionally, they can determine the maximum number of pieces that can be created with n slices of parallel or perpendicular lines. In combinatorial contexts, quarter square numbers indicate the count of nonempty subsets containing exactly one odd and one even element from a set $S = \{1, 2, 3, \dots\}$, as well as the ways to represent all integers within the interval $[3, n+1]$ as sums of two distinct natural numbers.

Finally, the study addressed geometric applications by identifying quarter square numbers as the number of lattice points (x, y) within a specified region of the coordinate plane, bounded by $y \leq n$ and $0 \leq y \leq \frac{n^2}{2}$. These findings collectively demonstrate the quarter square sequence's rich mathematical structure and its diverse applications across various fields, reinforcing its significance in both theoretical and practical contexts.

CONCLUSIONS

Based on the findings of the study, the following conclusions were formulated:

1. The quarter square sequence is a crucial mathematical construct, revealing rich interconnections with other integer sequences and enhancing our understanding of number theory.
2. The study established effective formulas for computing quarter squares, providing a systematic approach for generating values and emphasizing the sequence's mathematical structure.

3. Quarter squares demonstrate practical utility in various mathematical problems, such as maximizing products of integers, counting specific subsets, and representing integers as sums of distinct natural numbers, highlighting their relevance in combinatorial contexts.

4. The identification of quarter squares with lattice points in geometric configurations underscores their significance in spatial analysis, contributing valuable insights into mathematical visualization.

5. This study lays the groundwork for further exploration of quarter squares, inviting future research to investigate additional connections and applications, thereby reinforcing their importance in both theoretical and applied mathematics.

REFERENCES

- Cooper, S. B. (2008). The density of the odd quarter-squares. *The Fibonacci Quarterly*, 46(1), 53-58. <https://www.fq.math.ca/Papers/46-1/cooper.pdf>
- Conway, J. H., & Guy, R. K. (1996). *The book of numbers*. Springer. <https://doi.org/10.1007/978-1-4757-3180-1>
- Finch, S. R. (2003). Quarter-square constants. In *Mathematical constants* (pp. 242-244). Cambridge University Press. <https://doi.org/10.1017/CBO9780511755450.037>
- Finch, S. R. (2013). Quarter-square constants and congruences. *Journal of Integer Sequences*, 16, Article 13.8.7. <https://cs.uwaterloo.ca/journals/JIS/VOL16/Finch/finch18.html>
- Graham, R. L., Knuth, D. E., & Patashnik, O. (1994). *Concrete mathematics: A foundation for computer science* (2nd ed.). Addison-Wesley. <https://www-csfaculty.stanford.edu/~knuth/gkp.html>
- Guy, R. K. (2004). Quarter-squares and eighth powers. In *Unsolved problems in number theory* (3rd ed., pp. 169-172). Springer. https://doi.org/10.1007/978-0-387-24158-5_50
- Jacobsen, C. C. (2017). The sum of reciprocals of quarter-square integers. *Journal of Integer Sequences*, 20, Article 17.9.6. <https://cs.uwaterloo.ca/journals/JIS/VOL20/Jacobsen/jacobsen13.html>
- MathPages. (2005). Quarter-squares and eighth powers. Retrieved January 11, 2023, from <http://mathpages.com/home/kmath007/kmath007.html>
- Medrano, D., et al. (2023). On ruler sequence. Unpublished manuscript.
- Numberphile. (2014). Quarter-square problem. YouTube. Retrieved January 12, 2023, from <https://www.youtube.com/watch?v=XYVwKj6O7xw>
- OEIS Foundation. (2021). Quarter-squares. *The On-Line Encyclopedia of Integer Sequences*. Retrieved August 10, 2022, from <https://oeis.org/A001844>
- Rajan, C. S. (2016). Quarter square numbers and congruences. *Mathematics Newsletter*, 26(1), 16-20. https://www.tntech.edu/mcnair/images/Newsletter/Vol26No1/Quarter_Square_Numbers_and_Congruences.pdf
- Sloane, N. J. A. (2021). Quarter-squares. *The On-Line Encyclopedia of Integer Sequences*. OEIS Foundation. <https://oeis.org/A001844>
- Sloane, N. J. A. (2021). Neil Sloane's home page. Retrieved August 10, 2022, from <https://neilsloane.com/>
- Weisstein, E. W. (2021). Quarter-square. In *MathWorld--A Wolfram web resource*. Wolfram Research. <https://mathworld.wolfram.com/Quarter-Square.html>
- Wolfram Research. (2021). Quarter-square. *MathWorld--A Wolfram web resource*. Retrieved August 10, 2022, from <https://mathworld.wolfram.com/Quarter-Square.html>
- Gumaru, K., et al. (2023). On Lichtenberg sequence. Unpublished manuscript.
- Dislag, J., et al. (2023). On Riordan numbers. Unpublished manuscript.

INVESTIGATING THE CHARACTERISTICS AND RELATIONSHIPS OF THE LEIBNIZ HARMONIC NUMBER

John Martin G. Fontanilla
Joneil G. Pontejos

INTRODUCTION

Mathematics is a captivating field rich with intricate concepts and theories, and number theory is a particularly intriguing branch focusing on the properties and relationships of integers. This includes studying divisions, prime numbers, modular arithmetic, and the distribution of primes. One fascinating aspect of number theory is sequences, which are ordered lists of numbers following a specific pattern. Among these, the harmonic sequence stands out. It begins with $1/1$, followed by $1/2, 1/3, 1/4$, and so forth, where each term is the reciprocal of a positive integer. Another interesting structure in mathematics is Pascal's triangle, known for its patterns and applications in combinatorics and probability theory. Beyond Pascal's triangle, there are other intriguing structures like the Leibniz harmonic triangle.

The Leibniz harmonic triangle, introduced by the German mathematician Gottfried Wilhelm Leibniz in 1673, is a triangular array composed of unit fractions. In this array, each term can be denoted as $L_{(n,r)}$, where n indicates the row number (starting from 0) and r specifies the position within the row, ranging from 0 to n . This triangle exhibits a wealth of interesting properties and relationships, particularly with harmonic numbers, which are found along its outer diagonal.

Leibniz's triangle, also known as the Harmonic Triangle, not only reveals fascinating patterns but also connects with various integer sequences, offering deep insights into combinatorial mathematics and number theory.

This study aimed to examine the characteristics of Leibniz Harmonic Number. Specifically, it sought to answer the following questions:

1. What is Leibniz Harmonic Number?
2. What are the properties of Leibniz Harmonic Number?
3. How is Leibniz Harmonic Number related to:
 - 3.1 Central Binomial Coefficient;
 - 3.2 Catalan Number, and Triangular Number;
 - 3.3 Swinging Factorial;
 - 3.4 Apéry Number; and,
 - 3.5 Grand Dyck Path?

METHODS

Descriptive research involves recognizing and identifying a specific topic to be studied. The data were collected, organized, and analyzed so that it is descriptive. Moreover, the answers to the research questions were presented clearly and details. Expository research, on the other hand, requires researchers to examine and explore ideas, provide supporting evidence, and present particular perspectives and arguments. This can be achieved through a variety of strategies such as comparison, cause and effect analysis, and the use of examples. An expository method was used to illustrate and explain the ideas contained in Leibniz Harmonic Number.

RESULTS AND DISCUSSIONS

The researcher show that Leibniz Harmonic Number is a Central Denominator of Leibniz Harmonic Triangle denoted by L_n . Also, the $(n + 1)^{th}$ column and $(2n + 1)^{th}$ row of Leibniz Harmonic Triangle is given by the explicit formula $L_n = \frac{(2n+1)!}{n!^2}$.

This study showed some of the properties of Leibniz Harmonic Number based on the result of the study as follows;

1. The n^{th} term Leibniz Harmonic Number can be written as

$$L_n = \frac{n+1}{2} \binom{2n+2}{n+1}, n \in \mathbb{N}.$$

2. For every natural number n , Leibniz Harmonic Number can be generated in a recursive formula which is given by $L_n = 2L_{n-1} \left(2 + \frac{1}{n}\right)$, with $L_0 = 1$.

3. Every non-negative integer of Leibniz Harmonic Number can be written as

$$L_n = \frac{2^n(2n+1)!!}{n!}.$$

1. Leibniz Harmonic Number can be generated using Generating Function by

$$L(x) = (1 - 4x) - \frac{3}{2}.$$

The researchers found the relationship of Leibniz Harmonic Number to other number integer, as follows:

1. Leibniz Harmonic Number to Central Binomial Coefficients where n is a positive integer is given by $L_n = CBC_n \cdot (2n + 1)$.

2. Leibniz Harmonic Number to Catalan Number for every n is a natural number is given by $L_n = C_{n+1} \cdot T_{n+1}$.

3. Leibniz Harmonic Number to Swinging Factorial Number wherein n is integer given by $n!_{2n+1} = L_n$.

4. Leibniz Harmonic Number to Apéry Number in every n is element of positive integers is given by $L_n = \frac{A_{n+1}}{2}$.

5. Grand Dyck Path and Apéry Number to Leibniz Harmonic Number wherein n is element of natural number is given by $L_n = \frac{A_n \cdot G_{n-1}}{G_{n-1} - A_n}$.

CONCLUSIONS

Based in the following result/s of this study the researchers concluded the following;

1. Leibniz Harmonic Number is the central column value denominator of the Leibniz Harmonic Triangle. Leibniz Harmonic number can be derived using the formula of Leibniz Harmonic Triangle wherein $L_{(2m+1, n+1)}$.

2. Leibniz Harmonic Number can be derive using definition, theorems and properties.

3. The researcher explores different properties and characteristics of Leibniz Harmonic Number using various implicit formulas, recursive formula, double factorials and binomial formulas.

4. Leibniz Harmonic number can be express and expand using generating function $L(x) = (1 - 4x)^{-\frac{3}{2}}$.

5. The Leibniz Harmonic Number are related to Central Binomial Coefficient, Catalan Number, Triangular Number, Swinging Factorials, Apery Number and Grand Dyck Path.

REFERENCES

- Barcucci, E. and M.C. Verri, (1992). "Some more properties of Catalan numbers". *Discrete Mathematics*. Vol. 102, Issue 3, 229-237.
- Bicknell-Johnson, M. (1981). "Diagonal Sums in the Harmonic Triangle". *Fibonacci Quarterly*. Vol. 19, no. 3, 196-199.
- Boyadzhiev, K.N. (2012). "Series with Central Binomial Coefficients, Catalan Numbers, and Harmonic Numbers". *Journal of Integer Sequence*, Vol. 15. Article 12.1.7.
- James, L.T. (2019). "Analogues Between Leibniz's Triangle and Pascal's Arithmetic Triangle". *Electronic Theses, Projects, and Dissertations*. 835.
- Prudnikov, A. P., Brychkov Yu. A. and O.I. Marichev, (1992) "Integrals and Series", Volume 1: "Elementary Functions", Chapter 4: "Finite Sums", New York.
- Sivaraman, R. (2021). "On Some Properties of Leibniz's Triangle". *Mathematics and Statistics*. Vol. 9, No. 3, 209-217.
- Sloane, N.J.A. (2007). *The On-Line Encyclopedia of Integer Sequences*. DOI: 10.1007/978-3-540-73086-6_12

ON PROPERTIES AND RELATIONSHIPS OF THE GENERALIZED PYRAMIDAL NUMBER

*Carlos R. Avila
Larex B. Tagalog*

INTRODUCTION

Generalized pyramidal numbers are a fascinating category of figurate numbers created by arranging dots to form a pyramid with a polygonal base having K number of sides. These numbers captivate mathematicians due to their unique geometric shapes and their ties to various mathematical principles. This study focused into the properties and relationships of generalized pyramidal numbers, extending the classical notion of pyramidal numbers to higher dimensions and more complex combinatorial structures.

The study begins with an exploration of the combinatorial properties, revealing how these numbers can be interpreted through geometric configurations and lattice points. Recurrence relations are derived to describe the progression of generalized pyramidal numbers, providing a framework for their calculation and understanding their growth patterns. Additionally, generating functions are formulated, offering a powerful tool for encapsulating and manipulating these sequences. Through the generating functions, deeper insights are gained into the behavior and structure of generalized pyramidal numbers. Relationships between different classes of generalized pyramidal numbers are also examined, uncovering connections and analogies that enhance the comprehension of their intricate nature. By investigating these aspects, the research contributes to the broader field of combinatorial mathematics, providing new perspectives and methods for studying pyramidal numbers in a generalized context.

The purpose of this study is to discuss the definition of the Generalized Pyramidal Numbers. It also discusses some properties, relationships to other integer sequences, and its application.

1. What are Generalized Pyramidal numbers and how it is it generated?
2. What are the properties of K -gonal Pyramidal numbers?
3. How is Generalized Pyramidal number related to:
 - 3.1 Among K -gonal Pyramidal Numbers;
 - 3.2 Pascal Triangle; and
 - 3.3 Polygonal Number?
4. How is Generalized Pyramidal Number applied to the number of Polygonal grid?

METHODS

The research focuses on Generalized Pyramidal Numbers (GPN) through a descriptive and expository approach. It begins by explaining what GPNs are and how they are generated. This involves defining pyramidal numbers, including triangular, square, and K -gonal types, and outlining the step-by-step process of their formation.

Next, the research explores the properties of K -gonal Pyramidal Numbers, describing how different values of K influence their structure, growth patterns, and mathematical characteristics.

The study then investigates relationships between GPN and other mathematical constructs. It examines how K-gonal pyramidal numbers relate to each other, how GPN connects to Pascal's Triangle through binomial coefficients, and the link between GPN and Polygonal Numbers, showing that pyramidal numbers are sums of polygonal numbers.

Finally, the research applies the concept of GPN to counting polygonal grids, exploring how these numbers can model and organize grid systems in geometry.

RESULTS AND DISCUSSION

1. The results of the study provide a comprehensive understanding of K-gonal Pyramidal Numbers, which describe how objects can be arranged in the shape of a pyramid with a polygonal base. These numbers are represented by the formula:

$$P(K, n) = \frac{n^3(K - 2) + 3n^2 - n(K - 5)}{6}$$

where $P(K, n)$ represents the K-gonal Pyramidal Number, K refers to the number of sides of the polygonal base, and n is the height or number of levels in the pyramid. Several types of K-gonal Pyramidal Numbers are highlighted. When $K=3$ the result is the **Triangular Pyramidal Number**, also known as the **Tetrahedral Number**, representing objects arranged in a tetrahedral form. For $K=4$, the **Square Pyramidal Number** arises, describing a pyramid with a square base. Similarly, the **Pentagonal Pyramidal Number** corresponds to $K=5$, **Hexagonal Pyramidal Number** to $K=6$, and **Heptagonal Pyramidal Number** to $K=7$, each representing pyramids with increasingly complex polygonal bases. The formula provides a unified approach to calculating the number of objects in these various pyramid shapes. By changing the value of K , the base of the pyramid shifts from triangular to square, pentagonal, hexagonal, and beyond, showing the flexibility of the formula to accommodate different geometric structures. This generalization of pyramidal numbers not only provides insight into the specific cases but also establishes a clear relationship between the number of sides of the base and the structure of the pyramid.

2. Let $P(K, n)$ be a Pyramidal Number. The following are some properties of K-gonal Pyramidal Numbers.

One key property is the **recursive formula** for K-gonal Pyramidal Numbers, which allows for the calculation of $P(K, n)$ based on previous terms in the sequence:

$$P(K, n) = 4P(K, n - 1) - 6P(K, n - 2) + 4P(K, n - 3) - P(K, n - 4).$$

This recursive relation demonstrates how each pyramidal number can be derived from the preceding four numbers in the sequence, highlighting a specific pattern of progression.

The difference between consecutive K-gonal Pyramidal Numbers is given by:

$$P(K, n) - P(K, n - 1) = \frac{n}{2} [(K - 2)n - (K - 4)].$$

This expression defines how the pyramidal numbers change from one level to the next, reflecting the dependence on both the number of sides in the base K and the height n of the pyramid.

Another important result involves the **combination of binomial coefficients and arithmetic expression**, which provides an alternate method of calculating K-gonal Pyramidal Numbers: $P(K, n) = \frac{1}{3} \binom{n+1}{2} [(K-2)n - (K-5)]$.

This formula incorporates binomial coefficients, allowing for a compact expression that connects the number of levels and sides of the base.

The **generating function** for the K-gonal Pyramidal Numbers is expressed as:

$$G[P(K, n)](x) = \frac{x^{[(K-3)x+1]}}{(1-x)^4}.$$

This generating function is a powerful tool that encodes the entire sequence of K-gonal Pyramidal Numbers into a single algebraic expression, useful for studying the sequence's behavior and relationships with other mathematical structures.

Lastly, the **m-th partial sum** of the K-gonal Pyramidal Numbers is provided by:

$$\sum_{n=1}^m P(K, n) = S_m^K = \frac{1}{4} \left(\frac{m+2}{3} \right) [(K-2)m - K + 6].$$

This result gives a way to calculate the sum of the first mmm K-gonal Pyramidal Numbers, which is important in understanding cumulative patterns and trends within the sequence.

3. The relationships of K-gonal Pyramidal Numbers reveal key connections between these numbers and other mathematical structures. The general relationship among K-gonal Pyramidal Numbers is expressed by the formula:

$$P(K, n) = \frac{n^3 K - 2n^3 + 3n^2 - nK + 5n}{6}.$$

This formula demonstrates how the value of K (the number of sides of the polygonal base) and n (the number of levels in the pyramid) influence the structure and progression of these numbers.

Additionally, there is a connection between K-gonal Pyramidal Numbers and Pascal's Triangle. Both triangular numbers and tetrahedral numbers appear along the diagonals of Pascal's Triangle, establishing a direct link between these pyramidal figures and binomial coefficients.

Moreover, a specific relationship between pentagonal pyramidal numbers and triangular numbers is identified. The product of n and the n -th triangular number, denoted T_n , gives the pentagonal pyramidal number $P(5, n)$. This can be expressed symbolically as: $P(5, n) = n(T_n)$.

This relationship shows how the structure of pentagonal pyramidal numbers can be built from triangular numbers, emphasizing the interconnectedness between these different types of pyramidal and polygonal numbers.

4. K-gonal Pyramidal Numbers have practical applications in counting grid structures. For triangular grids, when $K = 3$, these numbers determine the total number of triangular units that can form a 3D triangular pyramid. Similarly, for square grids, when $K = 4$, they calculate the number of square units that can be arranged in a pyramid with a square base. These applications are valuable in areas like geometry and spatial modeling, where grid arrangements are analyzed.

CONCLUSIONS

Based on the findings of the study, the following conclusions were formulated:

1. **Generalized Formula:** The K-gonal Pyramidal Number formula provides a unified approach for calculating pyramidal numbers with various polygonal bases, demonstrating the flexibility of the structure across different values of K .
2. **Recursive Relationships:** The recursive formula for K-gonal Pyramidal Numbers reveals a clear pattern in their progression, allowing for the efficient computation of terms based on previous values.
3. **Connections with Pascal's Triangle:** There is a significant relationship between K-gonal Pyramidal Numbers and Pascal's Triangle, particularly in the case of triangular and tetrahedral numbers, which appear along its diagonals.
4. **Triangular and Pentagonal Pyramidal Numbers:** The product of $\binom{n}{k}$ and the $\binom{n}{k}$ -th triangular number generates the pentagonal pyramidal number, illustrating a strong interconnection between different types of pyramidal numbers.
5. **Applications to Grid Systems:** K-gonal Pyramidal Numbers are applicable in calculating the number of units in triangular and square grids, making them useful in geometric modeling and grid-based systems.

RECOMMENDATIONS

Based on the findings of the study, the following recommendations are proposed:

1. **Further Research on Higher Dimensions:** Future studies should explore the properties and applications of K-gonal Pyramidal Numbers in higher dimensions, potentially leading to new insights in multidimensional geometric modeling.
2. **Applications in Computer Science:** Researchers and practitioners in computer science and data structures could investigate the application of K-gonal Pyramidal Numbers in algorithm design and optimization problems, especially in grid-related computations.
3. **Educational Integration:** Incorporating K-gonal Pyramidal Numbers into educational curricula could enhance students' understanding of number theory and geometry, as they provide practical examples of mathematical concepts in action.
4. **Visualization Tools:** Developing visualization tools or software that illustrate the relationships and structures of K-gonal Pyramidal Numbers can aid in better understanding and teaching of these concepts, particularly in academic settings.
5. **Interdisciplinary Collaboration:** Encouraging collaboration between mathematicians, architects, and engineers can lead to innovative applications of K-gonal Pyramidal Numbers in real-world structural design and analysis.
6. **Exploration of Generalizations:** Researchers should examine the potential generalizations of K-gonal Pyramidal Numbers to other shapes and arrangements, expanding the theoretical framework and possible applications within mathematics.

REFERENCES

- Abramowitz, M., & Stegun, I. A. (Eds.). (1964). *Handbook of Mathematical Functions*. National Bureau of Standards, Applied Math.
- Ancora, L. (2016). *The Square Pyramidal Number and Other Figurate Numbers*.
- Beiler, A. H. (1964). *Recreations in the Theory of Numbers*. Dover.
- Benjamin, A. T., & Quinn, J. J. (2003). *Proofs That Really Count: The Art of Combinatorial Proof*. The Mathematical Association of America.
- Comtet, L. (1974). *Advanced Combinatorics*. Reidel.
- Conway, J. H., & Guy, R. K. (1996). *The Book of Numbers*.
- De Koninck, J. M., & Mercier, A. (2004). *Problèmes en Théorie Classique des Nombres, Problème*.
- Deza, M., & Deza, E. (2012). *Figurate Numbers*.
- Dickson, L. E. (1919). *History of Theory of Numbers*, Vol. 1.
- Dickson, L. E. (1920). *History of Theory of Numbers*, Vol. 2.
- Dickson, L. E. (1923). *History of Theory of Numbers*.
- Gardner, M. (1991). *Fractal Music, Hypercards, and More*. Freeman.
- Goldoni, G. (2002). A Visual Proof for the Sum of the First n Squares and for the Sum of the First n Factorials of Order Two.
- Holt, M. (1977). *Math Puzzles and Games*.
- Kazarinoff, N. D. (2009). Geometric Series and the Pyramidal Numbers. *Mathematics Magazine*, 82(4), 294-299. doi: 10.1080/00255700903106582
- Piskorz, P. J. (2016). *Square Pyramidal Numbers and the Multiplication Table*.
- Ray, P., Saha, S., & Biswas, A. (2014). On the Generalized K-gonal Pyramidal Numbers. *Journal of the Indian Mathematical Society*, 81(1-4), 197-216.
- Singh, R. K., & Agrawal, S. (2017). On K-gonal Pyramidal Numbers. *International Journal of Mathematics and its Applications*, 5(3-C), 185-190.
- Singmaster, D. (1982). *Sum of Squares and Pyramidal Numbers*.
- Sloane, N. J. A., & Plouffe, S. (1995). *The Encyclopedia of Integer Sequences*. Academic Press.
- Sloane, N. J. A. (1973). *A Handbook of Integer Sequences*. Academic Press.
- Williams, S. L. (1970). *A Bibliography of Recreational Mathematics (Vol. 2)*.

ONLINE SOURCES

Weisstein, E. W. (n.d.). Pyramidal Numbers. In MathWorld--A Wolfram Web Resource. Retrieved from <http://mathworld.wolfram.com/PyramidalNumber.html>

Cut-the-Knot. (n.d.). Geometric and Figurate Numbers. Retrieved from <https://www.cut-the-knot.org/Curriculum/Numbers/GeometricFigurate.shtml>

MathWorld. Square Pyramidal Number. Retrieved from <https://mathworld.wolfram.com/SquarePyramidalNumber>

OEIS Foundation Inc. Sequence A000330 (Square Pyramidal Numbers). Retrieved from <https://oeis.org/A000330>

ON DISMAL ARITHMETIC BOARD GAME

*Enrico P. Zara
Larex B. Tagalog*

INTRODUCTION

The oldest and most fundamental area of mathematics is arithmetic. It entails the study of numbers, particularly the characteristics of the standard operations—addition, subtraction, multiplication, and division—between them. Number theory, along with algebra, geometry, and analysis, is thought to be one of the top levels of modern mathematics. Arithmetic is a fundamental component of number theory. Prior to the 20th century, number theory was referred to as arithmetic and higher arithmetic, and these words are occasionally still used to designate a broader area of number theory. The earliest evidence of addition and subtraction is found in a tiny handful of artifacts, the best known of which is the Ishangobone from Central Africa, which dates from between 20,000 and 10,000 B.C. but whose interpretation is debatable. Although it developed considerably later than the Babylonian and Egyptian examples, modern arithmetic can be traced back to the Hellenistic civilization of ancient Greece. We suggest a "dismal arithmetic" that will be simpler to learn than the standard version in order to improve the pathetic state of arithmetic skills held by today's children. It is more straightforward since there are no carry digits, no need to add or multiply digits, and no need to perform any tasks that are more difficult than comparing. The partition function, the number of divisors, the sum of divisors, the prime analogs, and the comparison of the standard form of arithmetic are all covered in this paper's study of fundamental number theory in this universe. The researcher is eager to create this study in order to improve our analytical thinking for various study properties. We carry out this research 3 to assist our other students in learning more about the depressing operation and to encourage them to look for more novelties in the area of mathematics.

The purpose of this study is to discuss and give some details of proof about dismal sum and dismal product. It also discusses some properties of dismal sum and product in comparison to usual arithmetic.

1. What is Dismal Arithmetic?
2. What are the properties of Dismal Arithmetic?
3. How is Dismal Arithmetic related to Prime Numbers?
4. How is Dismal Sum and Product applied to D.A. Math Board Game?

METHODS

The study employed descriptive and expository methods to explore the properties and applications of Dismal Arithmetic. It began by defining and analyzing Dismal Addition and Multiplication, where each digit of the sum is the maximum, and each digit of the product is the minimum of the corresponding digits. These unique operations were compared to traditional arithmetic and applied to number-theoretic concepts like prime numbers and divisors. Additionally, a board game was developed to illustrate the practical use of Dismal Arithmetic, enhancing players' mathematical reasoning and logical deduction through strategic challenges. The methods effectively demonstrated the distinct nature and educational potential of Dismal Arithmetic.

RESULTS AND DISCUSSION

The study focused on exploring the unique characteristics of Dismal Arithmetic, specifically Dismal Addition and Dismal Multiplication. Dismal Addition, also known as the Dismal Sum, is defined as the operation where, for each corresponding digit of two numbers, the maximum value is taken. Conversely, Dismal Multiplication, or Dismal Product, selects the minimum value for each digit pair. This distinct arithmetic system challenges traditional concepts and introduces an alternative approach to numerical operations.

The research also examined various properties of Dismal Arithmetic. The concept of reversing was investigated, showing that reversing the order of digits in Dismal Arithmetic does not alter the result of addition or multiplication. The study also introduced the concept of length, where the number of digits in the sum or product depends on the maximum length of the addends or the combined lengths of the factors, respectively. Additionally, the notion of dominance was defined, where one number is considered to dominate another if each of its digits is less than or equal to the corresponding digits of the other number.

The study further confirmed that Dismal Arithmetic satisfies fundamental algebraic properties, such as commutative and associative laws, for both addition and multiplication. It also identified the existence of a Dismal Additive and Multiplicative Identity, although there are no Dismal Additive or Multiplicative Inverses. Notably, the Dismal system adheres to the distributive property of multiplication over addition, similar to traditional arithmetic.

Moreover, specific characteristics were observed for two-digit base 10 numbers in Dismal Arithmetic. For example, the square of such numbers follows a unique pattern depending on the relationship between the digits. These findings underscore the distinct nature of Dismal Arithmetic and its potential as an alternative mathematical framework.

CONCLUSIONS

Based on the findings of the study, the following conclusions were formulated:

1. **Unique Operations in Dismal Arithmetic:** Dismal Addition and Dismal Multiplication present an unconventional approach to arithmetic operations, where the maximum and minimum values of corresponding digits are taken, respectively. This system deviates from traditional arithmetic, offering a unique perspective on how numerical operations can be defined and executed.
2. **Properties Resembling Classical Arithmetic:** Despite its distinct methods, Dismal Arithmetic satisfies several fundamental algebraic properties, including the commutative and associative laws for both addition and multiplication. It also adheres to the distributive property of multiplication over addition, indicating a structured and systematic nature akin to classical arithmetic.
3. **Absence of Inverses:** Unlike standard arithmetic, Dismal Arithmetic lacks both additive and multiplicative inverses, which limits its application in solving equations that require these properties. However, it does possess unique additive and multiplicative identities, reinforcing its internal consistency.
4. **Reversal and Dominance Characteristics:** The study established that reversing the order of digits in Dismal Arithmetic does not alter the result of operations, and it introduced the concept of dominance, where one number can dominate another based on its digits. These findings highlight the innovative aspects of Dismal Arithmetic and its potential for further mathematical exploration.

REFERENCES

Sloane, N.J.A. Carryless Arithmetic. California, USA, 2012.

Sloane, N.J.A. Dismal Arithmetic. California, USA, 2011.

Frosini, A., & Rinaldi, S. "On the Sequence A079500 and Its Combinatorial Interpretations." *Journal of Integer Sequences*, 9 (2006), Article 06.3.1.

Brek, S., Frosini, A., Rinaldi, S., & Vuillon, L. "Tilings by Translation: Enumeration by a Rational Language Approach." *Electronic Journal of Combinatorics*, 13 (2006), Research Paper 15.

Goulden, I., & Jackson, D.M. *Combinatorial Enumeration*. Wiley, NY, 1983.

Stanley, R.P. *Enumerative Combinatorics*, Vol. 1. Wadsworth, Monterey, CA, 1986.

Pasola, S.H. *Game of the Generals (Salpakan)*. 1970.

ANALYSIS AND ASSESSMENT ON THE SOCIAL AMELIORATION PROGRAM BENEFICIARIES IN BARANGAY 130 AND BARANGAY 131, CALOOCAN CITY USING NATURAL LANGUAGE PROGRAMMING

Ador G. Utulo

INTRODUCTION

Social Amelioration Program is the governments' initiative to provide emergency subsidy to marginalized sectors -the poor households, indigent elderly, and informal sector workers and daily wage laborers -during the COVID19 pandemic under RA11469 Sec4(x). Emergency cash subsidy is given to beneficiaries to aid their financial needs during enhanced community quarantine through the Department of Social Welfare and Development in coordination with each barangay and local government units. In Caloocan City alone, a total of 367, 496 are beneficiaries of SAP from its 188 Barangays of which 1,277 are residents of Barangays 130 and 131. To qualify in the program, the beneficiary must be classified based on the given guidelines given by the DSWD. Several issues have been raised on who are qualified to receive social assistance especially information on how beneficiaries are selected and evaluated by the local government representatives. Some evaluators are also listing multiple individuals in a single household that are being considered as head of the family displaced due to the quarantine status. Based on the implementing guidelines in the distribution of cash assistance, each qualified beneficiary shall receive an amount ranging from 5,000 to 8,000 pesos. The amount allotted and indicated on the guideline to be given for each qualified beneficiary has also been reduced due to the increase in the number of target recipients. This study aims to validate the consistency on the implementation of the guidelines on the beneficiaries of the SAP program based on the list of names provided by the city government of Caloocan by analyzing the data using natural language processing.

METHODOLOGY

Data analysis involves loading, organizing, manipulating, modelling analyzing the data regardless of its origin. The list of beneficiaries of the Social Amelioration Program in Caloocan City is made available through its website www.caloocancity.gov.ph. The beneficiaries particularly for Barangay 130 and 131 have been extracted from the list provided. Based on demography, the total number of beneficiaries comprises of 1,277 individuals that represents 27% of its combined population of the two barangay and 0.35% of the total beneficiaries of the city.

Table 1
Demography

Barangay	Population*				SAP Beneficiaries**	
	Year 2015		Year 2020			
130	3,055	0.19%	2,527	0.15%	582	23%
131	2,286	0.14%	2,187	0.13%	695	32%
	5,341		4,714		1277	27%
Caloocan City	1,583,978		1,661,584		367,496	22%

Source: [*www.philatlas.com](http://www.philatlas.com)

[**caloocancity.gov.ph](http://caloocancity.gov.ph)

Using natural language processing, organizing, filtering and sorting of all the entities can be done by classifying the data into *data frames*. Data analysis using *pandas* library for python is applied to import the data from external sources such as excel file and the process of creating new table based on sorted *data frames*.

```
In [21]: df = pd.read_excel("sapbeneficiary.xlsx")

In [22]: df = df.sort_values(by='Lastname', ascending= True )

In [23]: print(df.head(10))
```

	Lastname	Firstname	Middle Name	Suffix	Barangay	Sex
582	ABADINES	RACHELLE	LUMINARIO	NaN	131	F
583	ABARQUEZ	REYNALDO	RODELAS	NaN	131	M
584	ABASTAS	GERALD	SARMIENTO	NaN	131	M
585	ABAYAN	STEPHANIE ANN	RUIZ	NaN	131	F
586	ACAYLAR	ROWELL	OROZCO	NaN	131	M
587	ADLAWAN	MARY JOY	CHAVEZ	NaN	131	F
0	ADOBAS	ERWIN	TORRES	NaN	130	M
1	ADOBAS	CHARIE	TORRES	NaN	130	F
2	ADOBAS	EDILBERTO	PALERO	NaN	130	M
588	ADOR DIONISIO	CATHERINE	PERELLO	NaN	131	F

```
In [24]: print(df.tail(10))
```

	Lastname	Firstname	Middle Name	Suffix	Barangay	Sex
1268	ZAPATA	JEN JEN	ROMERO	NaN	131	F
581	ZAPATA	ROMERO	RELOZA	NaN	130	M
1266	ZAPATA	FELICISIMO	PATAWARAN	JR	131	M
1265	ZAPATA	EDWARD	VALDERRAMA	NaN	131	M
1264	ZAPATA	ALEX	PANCHO	NaN	131	M
579	ZAPATA	AGNES	NALIAN	NaN	130	F
580	ZAPATA	ROMEO	RELOZA	NaN	130	M
1267	ZAPATA	ISABELA	MARIANO	NaN	131	F
1275	ZARATE	RONALYN	MAÑALAC	NaN	131	F
1276	ZIPATAN	CARIE	BALBUENA	NaN	131	F

Figure 1. Data Sorting Using Pandas

If the data entries having the same *lastname* belong to the same *barangay*, it is assumed that they belong to the same household and considered as one entity.

Table 2
Classification by Gender

SAP Beneficiaries			
Barangay	Male	Female	
130	254	328	582
131	311	384	695
Total	565	712	1277

RESULTS AND DISCUSSION

Based on classification by gender, the beneficiaries of the social amelioration program in barangays 130 and 131, 55.76% are female and 44.24% are female. Aggregating the data on beneficiaries *lastname* living in the same barangay will reduce the number of beneficiaries per household.

Lastname	Firstname
ADOBAS	ERWIN, CHARIE, EDILBERTO
ADRES	CLARK
AGDAMAG	EMMA
AGONCILLO	JUNELYN
AGUILAR	MARK ANTONLY
...	...
VILLOZA	RICHARD
WONG	MICHAEL
YU	MARIETA
YUZON	JESSICA
ZAPATA	AGNES, ROMEO, ROMERO

[320 rows x 1 columns]

Figure 2. Aggregate List for Barangay 130

Aggregating the list of the beneficiaries for barangay 130 by lastname will result to reducing the number from 582 to 320 recipients who will be receiving cash assistance from the program.

Lastname	Firstname
ABADINES	RACHELLE
ABARQUEZ	REYNALDO
ABASTAS	GERALD
ABAYAN	STEPHANIE ANN
ACAYLAR	ROWELL
...	...
VILLONES	RAYMONG PAUL
VISDA	JAYSON, LEONORA
ZAPATA	ALEX, EDWARD, FELICISIMO, ISABELA, JEN JEN, JE...
ZARATE	RONALYN
ZIPATAN	CARIE

[389 rows x 1 columns]

Figure 3. Aggregate List for Barangay 131

Aggregating the list of the beneficiaries for barangay 131 by *lastname* will result to reducing the number from 695 to 389 recipients who will be receiving cash assistance from the program.

Table 3
Qualified Beneficiaries, If Filtered by “Lastname” and “Barangay” as Subset Index

Barangay		Lastname
130	582	320
131	695	389
Total Beneficiary	1277	709

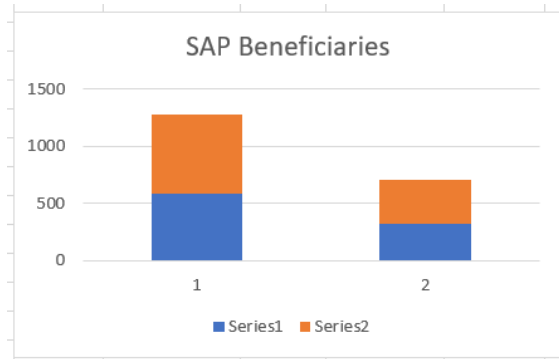

Figure 4. Graph Showing the Reduce Number of Beneficiaries

If filtered or aggregated by *lastname* and *barangay* as subset index, the total number of beneficiaries will be reduced to 709. This result can be applied since we can assume that in every household beneficiary from the same barangay having the same lastname are considered to be living in a single household.

Table 4
Qualified Beneficiaries, If Filtered by “Lastname” as Subset Index

Barangay 130 & 131	Lastname	
Total Beneficiary	1277	635

If filtered or aggregated by *lastname* as subset index alone, the total number of beneficiaries will be reduced to 635 which is not ideal since we cannot assume the relativity of the individuals having the same *lastname* living on different barangays.

CONCLUSION

The implementation of the government’s social amelioration program is its first step towards poverty alleviation and hunger reduction during the COVID-19 pandemic crisis. Success in any government program is always gauge based on transparency in the delivery of goods and services as performed by its officials who are implementing the program. Each government programs also requires financial funding and allotment. Guidelines in the implementation of the program with regards to selection and verification of beneficiaries should be followed to properly disseminate the funds allotted in the program. The most common problem identified is listing multiple number of recipients in each household even if the other person is not qualified in the program. Natural language processing or machine learning may be adapted in verifying list of beneficiaries to minimize redundancy in listing the qualified individuals or household in the program. The list provided by the city government should be updated indicating the category of the individual whom they identified to be qualified in the social amelioration program for evaluation and validation processes. Data analysis using natural language programming can enhance the process of evaluating and validating list of submitted beneficiaries to qualify in implementing the governments’ social amelioration program.

REFERENCES

- [1] G-Watch Philippines, *Result and Analysis of G-Watch's Online Survey on the State of the Social Amelioration Program (SAP) Implementation*. June 2020
- [2] National Budget Memorandum No. 136, May 2020, Published on the NEDA website, May 21, 2020
- [3] DSWD Memorandum Circular No. 04 Series of 2020
- [4] Republic Act No. 11469, Section 4(x) page 10, *Bayanihan to Heal as One Act*
- [5] <https://caloocancity.gov.ph/programs-and-projects/news/1194-list-of-beneficiaries-of-social-amelioration-program>
- [6] <https://www.youtube.com/channel/UCJHs6RO1CSM85e8jIMmCySw>, Sherril, Derrick
- [7] <https://www.philatlas.com>
- [8] <https://car.dswd.gov.ph/programs-services/social-amelioration-program/.com>

PC – BASED SECURITY CAMERA WITH ALARM SYSTEM USING IMAGE PROCESSING

Ador G. Utulo

INTRODUCTION

The idea of an intelligent life system has emerged due to people's desire for safety and a higher quality of living, which has occurred concurrently with the fast advancements in modern automation technology. In this approach peoples' sense of security increases. Security is an issue both to an individual, and even in a community. Traditional security like alarm systems and roaming barangay officers can provide some amount of security, but they may not be considered enough and cost-effective. Varieties of advanced technologies have been developed and a lot of organizations are pouring in support to several ongoing researches that is being done in the security field. It may be utilized to carry out several tasks that save human life. Employing advanced motion detectors, for instance, add to home and property security. By incorporating sensors and cameras to monitor various tasks carried out on a regular basis, real-time with artificial intelligence, can bring ease to human life; make the environment more safe and secure.

In this study, in order to improve the security of a location. This proposed system is a potential option that combines the powers of a computer, webcam or IP camera, and advanced image processing software. This cutting-edge technology makes use of computer vision and artificial intelligence to quickly identify possible threats and suspicious activity. This security camera system may access the computing power necessary for challenging image analysis tasks by using a PC or laptop as the central processing unit. The system is made to take video frames from an IP camera or webcam attached to it, process those using specialized algorithms, and produce alerts or set off alarms when certain events or objects as found. The integration of an alert system is one of the main characteristics of this PC-Based Security Camera with Alarm System using Image Processing. The system may examine video frames that have been processed and find predetermined triggers for sounding the alert by using current or custom-made alarm system software. These triggers offer a versatile and scalable security solution since they may be based on motions, specific objects or other predefined criteria.

METHODOLOGY

To attain the objectives of the study, the following were performed:

Research Locale

This study is conducted in Barangay 635, Sta. Mesa, Manila that serves as the specific area of focus for this research project. Situated within the city of Manila, this barangay is a diverse community and experiences various security challenges. By conducting the research in this specific locale, valuable insights can be gained into the needs of barangay. The study will assess the system's ability to detect fire, cigarette smoking and playing cards within its vicinity.

Research Design

The researcher used the Design and Development Research Methods which entails: addressing an acknowledged problem, building upon existing literature, and making an original contribution to the body of knowledge (). Identification of the problem motivating the study was the first step in design and development research (Preffers et al., 2007). Literature support is vital for all research as a means of placing the study in the context of the existing body of knowledge

(Levy & Ellis, 2006) and establishing the presence, importance, and nature of the problem driving the research (Ellis and Levy 2008). This study researched and recognized fire, smoking cigarette, and playing cards as the issue in today's society. Specific to design and development types of studies, a number of design decisions were made throughout the process; the theoretical basis for the decisions reached is likewise supported through the literature (van den Akker, 2000) which resulted in the PC-based security camera with alarm system using image processing design by the researcher. The five major steps in Design and Development Research are: 1) Construct the conceptual framework; 2) Develop the PC-based security camera with alarm system using image processing system architecture. 3) Analyse and design the PC-based security camera with alarm system using image processing. 4) Build the PC-based security camera with alarm system using image processing; and 5) Test the PC-based security camera with alarm system using image processing and have it assessed by the respondents. Descriptive research design was also used due to the quantifiable information gathered and used for statistical inference from the respondents. It was used as a method to reveal, define, and measure the strength of the respondents' opinion, attitude, or behavior with regards to the significance of this study.

Respondents of the Study

The users of this system are barangay officials that handle operations of the CCTV. Barangay chairman, seven (7) barangay council, secretary and treasurer used and evaluated the system based on functionality, reliability, usability, security, operability and maintainability. (Evaluated ISO we use the following characteristics).

Research Instrument

The following instruments are used to supply the data needed for this study: Data gathering. The researcher personally conducted interviews with barangay officials in order to gain accurate insight and observations on the process of treatment. Furthermore, the requirements for the development, establishment, and improvement of PC-based security camera with alarm system using image processing was enumerated and reiterated to target respondents. Validation of instrument. It is the process by which any data collection instrument, including questionnaires, is assessed for its dependability. The researcher used the five-point Likert scale in order to rate the answers, from less of something to more of something on a continuum. It provides a numeric representation of a descriptive interpretation. Indicators for project evaluation. PC-based security camera with alarm system using image processing was assessed based on ISO 9126 using the following indicators for evaluation: Functionality. It refers to the capabilities and features of the PC-based security camera with alarm system using image interact with and operate the PC-based security camera with alarm system using image processing. Security. It focuses on protecting the PC-based security camera with alarm system using image processing from unauthorized access, data breaches, and tampering. Operability. It refers to the ease with which the PC-based security camera with alarm system using image processing can be operated, controlled, and managed by authorized personnel. Maintainability. It relates to the ease with which the PC-based security camera with alarm system using image processing can be maintained, updated, and repaired.

Statistical Treatment of Data

The purpose of statistical treatment in this research study is to analyze and interpret the data collected from the PC-based Security Camera with Alarm System using Image Processing.

Block Diagram

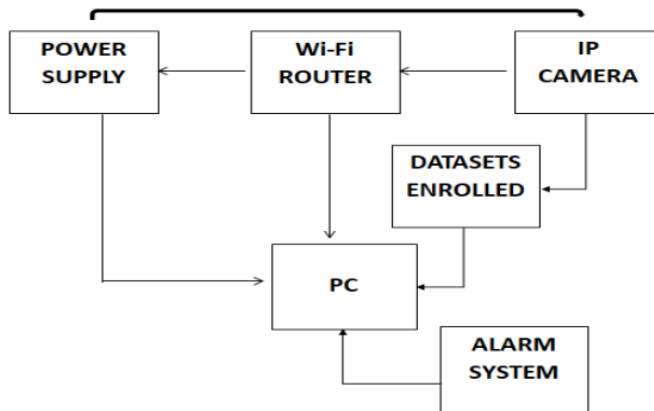

Figure 1. Block Diagram of the System

1. The Power Supply is the source of electrical power for the devices e.g. Wi-Fi Router, PC, and IP Camera.

2. The PC is a personal computer, likely used for monitoring and managing the IP cameras and alarm system. It can also serve as a data storage and processing unit.

3. IP Camera: These are cameras that can capture and transmit video over the network, using the Internet Protocol (IP). They can be connected to the PC and the Wi-Fi router.

4. The Wi-Fi router is responsible for creating a local wireless network, allowing devices like the PC and IP cameras to connect wirelessly to each other.

5. Wi-Fi router>PC>IP Camera: This connection sequence indicates that the IP camera is connected wirelessly to the Wi-Fi router, and the PC is also connected to the same Wi-Fi router. The PC can communicate with the IP camera and access its video feed and settings over the wireless network.

6. Data sets, this is the data used to train the machine learning algorithm. It contains a large number of labelled examples, where the correct target or output is known.

7. Alarm: This represents an alarm system that might be triggered by objects, such as Playing cards, Cigarette Smoke and Fire from the IP camera.

8. The PC seems to be responsible for sending signals or commands to the alarm system based on the data it receives from the IP camera. For example, if the camera detects objects, the PC may trigger the alarm. The diagram illustrates configurations for connecting and utilizing IP cameras, a PC, Wi-Fi router, and an alarm system. The IP cameras can capture and transmit data to the PC, which serves as the central processing and control unit. The PC can then use the data for monitoring, analysis, and activating the alarm system as needed. The Wi-Fi router enables wireless connectivity among the devices in the setup.

RESULTS AND DISCUSSION

This section presents the result and findings of data gathered in the development and design of the PC-based Security Camera with Alarm System using Image Processing.

The respondent's evaluation of the PC-based Security Camera with Alarm System using Image Processing Project. The following are the respondent's evaluation of PC-based Security Camera with Alarm System using Image Processing based on the following indicators: functionality, reliability, usability, security, operability and maintainability.

Presentation of Objective No. 1

Create a PC-based application that can be used by the system user to monitor the events within the Barangay.

This PC- Based Application monitor events or activities in the Barangay and is designed that comprises of the user interface and camera layer of the application for the purpose of displaying the information from the user that runs from the web browser of the desktop application as GUI developed using (front end) Python.

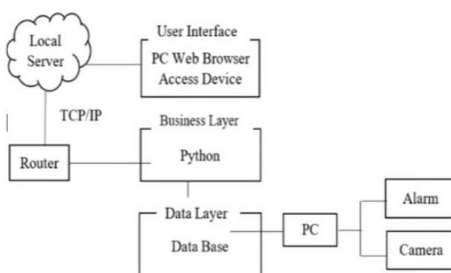

Figure 2. Integration Diagram of the System

The figure shows the business layer for processing the business rule and it was developed using python to communicate using the system API cells. The data tier processed more the stored information and communicate with the business layer or to the application tier for the server and programs that access the database.

Presentation of Objective No. 2

Design a security system that can detect activities or event such as fire, cigarette smoking and playing cards.

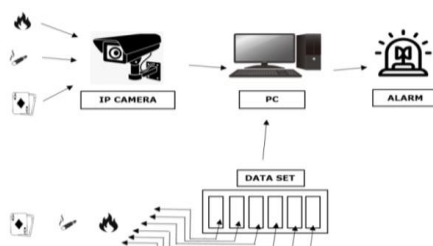

Figure 3. Architecture Diagram of the System

Presentation of Objective No. 3

Design an image processing application that can notify the system user if certain events happen.

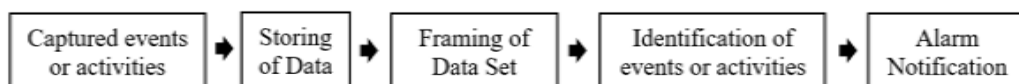

Figure 4. Activity Diagram of the Security System of the System

The image processing capability of the application used open source library. It used machine learning with built in function to perform the complex operation on images. The activity diagram of the proposed system is presented to demonstrate the objective no.3 of its logic process or workflow between the users and the system. The demonstration shows the start point to details the paths that containing the activity and to detail the parallel processing in the execution of the activities of the system.

Presentation of Objective No. 4

Improve the barangay system in using the surveillance camera in identifying events or activities.

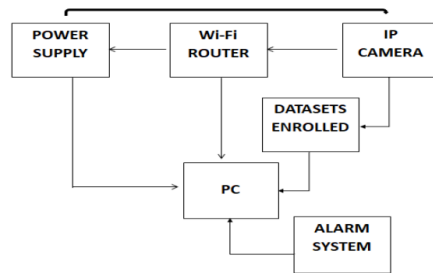

Figure 5. Functional Diagram of the PC-based Security Camera with Alarm System Using Image Processing Techniques

The enhancement of the infrastructure of the organization is to deliver the value and streamline the organization operation in decision making. This demonstration presented of this objective is presented to visualized the functionality of the system and understand the flow used to model the sequential work flow steps of the proposed application as shown in the figure as innovation of their existing system.

Presentation of Objective No. 5

Integrate an alarm system that can notify or warn the system user if an activity or event occurred or exists.

The alarm system design incorporate to the architecture of the proposed system is to provide early warning to detect intrusion and manage time to respond. Figure 5, shows the local alarm output that can be used to audible or for visual indication to alert the operator of the system in the PC vicinity as well as the other relay. In the main alarm selection, the user allows to choose which relay can be for the alarm, with in K0 TO K7 of the relay output and the USB interface device is plugged to any available USB port for power operation.

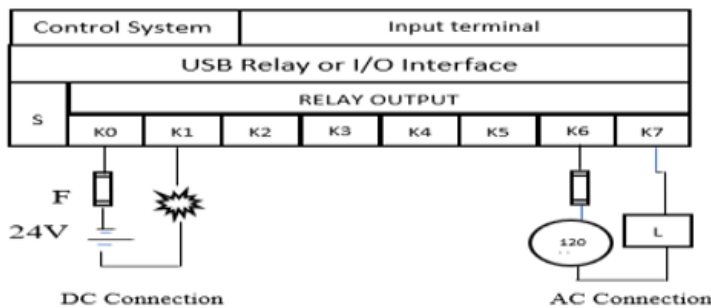

Figure 5. AC DC Connection of the Alarm System of the PC-based Security Camera with Alarm System Using Image Processing

Presentation of Objective No. 6

Evaluate the proposed system's characteristics in terms of its performance based on ISO 9126 model characteristics.

The interpretation of statistical results helps researchers communicate the significance and relevance of their findings to the broader field of study. For functionality as gleaned from Table 2, the data show that among the indicators pertinent to rank 1 is "The specified events or activities stated by the proposed project that can be captured are performed" with weighted of mean 4.40 of which is verbally interpreted as excellent. The ranked two indicator "The application's performance of the project task required achieve." Has weighted mean of 4.20 which is verbally interpreted as very satisfactory. The ranked three indicator "The output of results of the present project's performance is satisfactory." has weighted mean of 3.70 which is verbally interpreted as very satisfactory. The functionality of the proposed project, as indicated by the average weighted mean of 4.10, is classified as very satisfactory. These findings highlight the strong functionality of the PC-based Security Camera with Alarm System using Image Processing, indicating its effectiveness in performing the desired tasks and meeting the project objectives.

For reliability as gleaned from Table 3, the data show that among the indicators pertinent to rank 1 is "The responsiveness in sending alerts and notifications to relevant authorities" with weighted of mean 4.50 of which is verbally interpreted as excellent. The ranked two indicator "The consistency in terms of detecting incidents and triggering appropriate alarms" has weighted mean of 3.90 which is verbally interpreted as very satisfactory. The ranked three indicator "The system's uptime and availability" has weighted mean of 3.60 which is verbally interpreted as very satisfactory. The reliability of the proposed project, as indicated by the average weighted mean of 4.00, is classified as very satisfactory. These findings highlight the system's high usability, suggesting that the PC-based Security Camera with Alarm System using Image Processing effectively meets user needs and requirements.

For usability as gleaned from Table 4, the data show that among the indicators pertinent to rank 1 is "Easy to navigate the system's user interface" with weighted of mean 4.60 of which is verbally interpreted as excellent. The ranked two indicators "Easy to understand the system's basic functions" has weighted mean of 4.50 which is verbally interpreted as excellent. The ranked three indicator "The system's capability to detect and identify incidents" has weighted mean 4.00 of which is verbally interpreted as very satisfactory. The usability of the proposed project, as indicated by the average weighted mean of 4.37, is classified as excellent. These findings highlight the system's high usability, suggesting that the PC-based Security Camera with Alarm System using Image Processing effectively meets user needs and requirements.

For security as gleaned from Table 5, the data show that among the indicators pertinent to rank 1 is "The physical component such as system unit is secured from unauthorized personnel" with weighted of mean of 4.60 which is verbally interpreted as excellent. The ranked two indicator "The windows security is updated for virus and threat protection" has weighted mean of 4.30 which is verbally interpreted as excellent. The ranked three indicator "The system is password protected" has weighted mean of 4.00 which is verbally interpreted as very satisfactory. The security of the proposed project, as indicated by the average weighted mean of 4.30, is classified as excellent.

These findings highlight the system's strong security features, emphasizing its capability to ensure the confidentiality, integrity, and availability of the PC-based Security Camera with Alarm System using Image Processing.

For operability as gleaned from Table 6, the data show that among the indicators pertinent to rank 1 is “Ease of initiating system operation” with weighted of mean of 4.00 which is verbally interpreted as very satisfactory. The ranked two indicator “Easy to set up, and configure the system, network connectivity, and alarm settings” has weighted mean of 3.90 which is verbally interpreted as very satisfactory. The ranked three indicator “Easy to grasp the basic functionalities of the system and understand how to operate” has weighted mean of 3.60 which is verbally interpreted as very satisfactory. The operability of the proposed project, as indicated by the average weighted mean of 3.87, is classified as very satisfactory. These findings demonstrate the high operability of the PC-based Security Camera with Alarm System using Image Processing, indicating that it effectively facilitates user interactions and operations within the system.

For maintainability as gleaned from Table 7, the data show that among the indicators pertinent to rank 1 is “Easy to perform routine such as updating software” with weighted of mean of 4.00 which is verbally interpreted as very satisfactory. The ranked two indicator “The system incorporates remote capabilities, allowing authorized personnel to remotely access and diagnose the system for troubleshooting purposes” has weighted mean of 3.60 which is verbally interpreted as very satisfactory. The ranked three indicator “Easy to replace defective or upgrade the system's components” has weighted mean of 3.40 which is verbally interpreted as satisfactory. The maintainability of the proposed project, as indicated by the average weighted mean of 3.67, is classified as very satisfactory. These findings highlight the system's strong maintainability features, emphasizing its ability to be easily serviced and upgraded as needed.

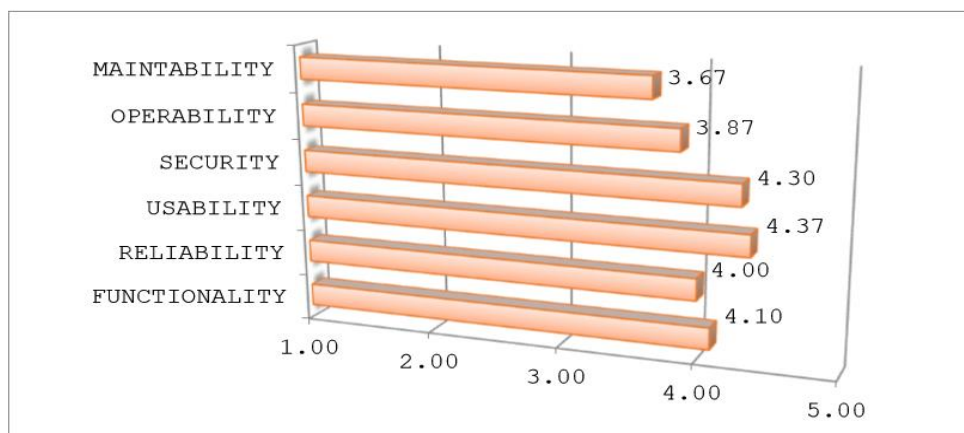

Figure 6. Data Visualization of the Result

SUMMARY AND CONCLUSION

Summary of Findings

That based on the foregoing objectives of the study, the following salient findings were drawn from the evaluation as follows: The proposed system was able to provide and demonstrate to the respondents its needed features and functionalities. The evaluation of the respondents in terms of the system's functionality, reliability, usability, security, operability and maintainability and garnered with the stated weighted mean ranging from 3.6 to 4.3 and with interpretation of “Very Satisfactory” and “Excellent”.

Conclusions

This section presents the researcher's drawn conclusions based on the results of the summary of findings and their alignment with the research objectives. That based on the results, the conclusion obtained and interpreted the data, the researchers found that PC-based Security Camera with Alarm System using Image Processing in enhancing security and surveillance measures in Barangay 635, Sta. Mesa, Manila. It can address and achieves its intended purpose and contributes to incident detection and response capabilities for security in the area. The system user is the expert that can positively demonstrate and assess the proposed system results to an average of excellent rating to make the system very helpful and efficient tool in assisting the process of monitoring for security measures. Therefore, based on the results of the interpreted data, the researchers successfully attained the project objectives of the study.

REFERENCES:

- [1] Baballe, M. A., Abdullahi, A., Muhammad, A. S., & Saleh, Y. The Various Types of sensors used in the Security Alarm system. (2020)
- [2] Byrne, J., & Marx, G.. Technological Innovations in Crime Prevention and Policing. A Review of the Research on Implementation and Impact. (2023)
- [3] Cavas, M., & Baballe, M. A. A Review Advancement of Security Alarm System Using Internet of Things (IoT). (2019)
- [4] Chen, Q., Xu, J., & Koltun, V. Fast Image Processing with Fully-Convolutional Networks. (n.d.). Dequiros, R. A., Catacutan, C. L., Cruz, J. V., Ziganay, K. D., & Guarin, B. M. TRENDSAFE: Intrusion Alarm System for Smart Home Protection and Security Using Arduino with SMS Notification. (2022).
- [5] Guillermo, M., Tobias, R. R., Jesus, L. C., Billiones, R. K., Sybingco, E., Dadios, E. P., & Fillone, A. Detection and Classification of Public Security Threats in the Philippines Using Neural Networks. (2020).
- [6] Habal, B. G., Malasaga, E. V., & Magpantay, A. T.. An Experimental Approach on Detecting and Measuring Waterbody through Image Processing Techniques. (2021)
- [7] Jost, D. What is a Motion Sensor? (2019, October 14).
- [8] Jr., M. G., & Festijo, E. D. Vehicle Tracking and Monitoring: A Security System for Exclusive Subdivision. (2023).
- [9] Laufs, J., & Borrior, H.. Technological Innovation in Policing and Crime Prevention: Practitioner Perspectives From London. (2021)
- [10] Macrotrends. Philippines Crime Rate & Statistics 1990-2023. (2019)
- [11] Malbog, M. A., Grimaldo, H. D., Lacatan, L. L., Delloso, R. M., & Austria, Y. D. LPG Leakage and Flame Detection with SMS Notification and Alarm System: Rule-Based Method. (2020)
- [12] Militante, S. Fruit Grading of Garcinia Binucao (Batuan) using Image Processing. (2019).
- [13] Moen, E., Bannon, D., Kudo, T., Graf, W., Covert, M., & Valen, D. V. Deep Learning For Cellular Image Analysis. (2019)
- [14] Ocampo, Y. AI to Boost Public Safety, Security in the Philippines. (2022)
- [15] Piza, E. L., Welsh, B. C., Farrington, D. P., & Thomas, A. L. CCTV Surveillance for Crime Prevention. A 40-year Systematic Review with Meta-Analysis (2019).



Behavioral Research

HEALTH CARE
TREATMENT
MEDICAL CARE
PREVENTION
DIAGNOSIS

RESEARCH
INNOVATION
TECHNOLOGY
IDEA
SOLUTION
INSPIRATION

QUALITY MANAGEMENT SYSTEM PRACTICES, ORGANIZATIONAL PERFORMANCE, AND EMPLOYEE ENGAGEMENT OF STATE UNIVERSITIES AND COLLEGES IN THE CALABARZON REGION: BASIS FOR A PROPOSED INTERVENTION PROGRAM

Rommuel E. Abanto

Introduction

State Universities and Colleges (SUCs) serve as vital pillars in the Philippine education system, tasked with the dual responsibility of delivering high-quality education and managing resources efficiently. These institutions play a critical role in meeting the diverse expectations of stakeholders, including students, faculty, government bodies, and the wider community. However, SUCs often grapple with numerous challenges such as resource limitations, bureaucratic complexities, and evolving educational policies that can hinder their operational effectiveness (Felix Jr et al., 2020).

To address these pressing challenges, the implementation of a robust Quality Management System (QMS) emerges as an essential strategy. A well-structured QMS facilitates the establishment of high standards of quality in educational processes and operations, ensuring that institutional goals align with stakeholder needs and comply with regulatory requirements (Garcia, 2013). Furthermore, QMS fosters a culture of continuous improvement, promoting operational efficiencies and enhancing the overall educational experience.

In parallel, employee engagement stands out as a critical factor influencing organizational performance. Engaged employees, especially in educational settings, demonstrate heightened levels of motivation, commitment, and job satisfaction, leading to improved outcomes in teaching and administrative functions (Marmar, 2020). However, fostering employee engagement within SUCs can be particularly challenging due to factors such as workload pressures, ineffective communication channels, and hierarchical complexities that may alienate staff (Harivelle Ligaya & Zalamea, 2015).

Previous research underscores the dynamic and mutually reinforcing relationship among QMS practices, organizational performance, and employee engagement. An effectively implemented QMS streamlines processes, reduces operational errors, and enhances stakeholder satisfaction (Koskela et al., 2019). Moreover, a culture of continuous improvement, underpinned by strong leadership and strategic planning, drives elevated levels of organizational performance and employee engagement (Andres, 2019). Against this backdrop, the present study seeks to evaluate the current state of QMS practices, organizational performance, and employee engagement in SUCs within the CALABARZON Region. The goal is to provide a comprehensive foundation for a proposed intervention program designed to enhance institutional effectiveness.

METHODS

The study employed a descriptive research design, utilizing a researcher-made questionnaire validated by field experts to gather data from selected respondents. Conducted from November 2022 to April 2023, the research encompassed five prominent SUCs in the CALABARZON region: Cavite State University (CaVSU), Laguna State Polytechnic University (LSPU), University of Rizal System (URS), Eulogio Amang Rodriguez Institute of Science and Technology (EARIST), and Technological University of the Philippines – Cavite (TUPC). A total of 255 respondents were selected through purposive and total sampling methods, comprising 55 school administrators, 125 faculty members, and 75 non-teaching personnel.

The data collection instrument focused on three primary areas: assessment of QMS practices, evaluation of employee engagement, and determination of organizational performance. The QMS assessment included dimensions such as leadership commitment, planning processes, support mechanisms, operational processes, and performance evaluation practices. Employee engagement was examined in terms of job satisfaction, motivation, participation in institutional decision-making, and recognition of contributions. Organizational performance was evaluated based on a range of indicators including service quality, employee productivity, stakeholder satisfaction, and institutional growth.

Data analysis involved the use of various statistical tools, including weighted mean calculations, t-tests to assess group differences, and Pearson correlation coefficients to determine relationships among the variables. This comprehensive analytical approach enabled a nuanced understanding of the interplay between QMS practices, employee engagement, and organizational performance across the selected SUCs.

Table 1
Distribution of Respondents

Group	Sample Size
Administrators	55
Faculty	125
Non-Teaching Staff	75
Total	255

RESULTS AND DISCUSSION

Overview of Findings

The study's results indicated that QMS practices within the selected SUCs were moderately implemented across various operational and managerial dimensions. The overall weighted mean for QMS practices was 4.17, suggesting that while institutions maintain foundational quality management systems, several areas, particularly performance evaluation and support for continuous improvement initiatives, require further enhancement to realize their full potential.

QMS Practices Assessment

Analysis of QMS practices revealed that respondents from all three groups (administrators, faculty, and non-teaching personnel) reported moderate engagement with key QMS components. Essential elements such as leadership commitment, effective planning processes, and operational support were moderately practiced. However, areas like performance evaluation and feedback mechanisms were identified as less robustly implemented, indicating a critical need for a more data-driven approach to decision-making and continuous process evaluation.

Furthermore, respondents expressed a pressing need for enhanced communication and targeted training to facilitate QMS implementation, particularly in areas demanding specialized knowledge and resource management (Andres, 2019). This highlights the importance of building capacity within institutions to ensure all staff members are equipped to contribute effectively to QMS initiatives.

Employee Engagement

The study also assessed employee engagement levels, which were found to be moderate across the respondent groups. While there were varying degrees of satisfaction and involvement in institutional decision-making processes, notable concerns emerged. Faculty members raised issues regarding limited opportunities for professional development and recognition of their contributions, while non-teaching staff pointed to challenges related to heavy workloads and communication breakdowns.

Despite these challenges, the positive correlation between employee engagement and organizational performance suggests that initiatives aimed at improving engagement levels could yield significant improvements in institutional efficiency and service quality (Lobo, 2023). Therefore, it is imperative for SUCs to prioritize strategies that enhance employee participation in decision-making, foster a culture of recognition, and create pathways for professional growth.

Organizational Performance

Organizational performance of SUCs in the CALABARZON region received high ratings from a majority of respondents, with an overall weighted mean of 4.19. Key performance indicators, including productivity, teamwork, and employee satisfaction, were closely aligned with the implementation of QMS practices, reinforcing the notion that effective quality management systems directly contribute to institutional success (Harivelle Ligaya & Zalamea, 2015). However, respondents also identified critical areas for improvement, such as enhancing infrastructure, updating institutional policies, and ensuring that all personnel receive adequate training in QMS procedures.

The findings suggest that while the institutions are performing well overall, sustained efforts in improving infrastructure and policies, alongside a commitment to ongoing training, will be essential for maintaining and enhancing organizational performance in the future.

Correlational Analysis

The Pearson correlation analysis revealed significant positive relationships between QMS practices and organizational performance ($r = 0.76$, $p < 0.05$), as well as between organizational performance and employee engagement ($r = 0.71$, $p < 0.05$). These findings underscore the importance of improving QMS practices—particularly in leadership, operational efficiency, and performance evaluation—as these enhancements are likely to positively impact both employee engagement and overall institutional performance.

CONCLUSIONS AND RECOMMENDATIONS

The study concludes that while QMS practices are moderately implemented across SUCs in the CALABARZON region, there is a clear need for targeted enhancements in specific areas, such as performance evaluation, communication, and employee engagement. The significant positive correlations identified between QMS, organizational performance, and employee engagement highlight the importance of adopting a more integrated and holistic approach to quality management in educational institutions.

In light of these findings, the researcher proposes the "School Management Program," a comprehensive intervention designed to enhance process quality and ensure institutional sustainability. The key components of this program include:

1. Leadership Development: Focusing on enhancing leadership commitment to QMS through regular training sessions, strategic planning initiatives, and performance monitoring practices. This development will empower leaders to effectively champion quality management efforts within their institutions.

2. Process Improvement: Implementing data-driven strategies for continuous improvement, including the establishment of regular performance evaluations, feedback mechanisms, and stakeholder consultations. These strategies will ensure that institutions remain responsive to changing needs and can adapt their processes accordingly.

3. Employee Engagement Initiatives: Introducing targeted programs aimed at increasing employee participation in decision-making processes, providing professional development opportunities, and establishing robust recognition systems. Such initiatives will not only improve engagement levels but also foster a more inclusive and collaborative organizational culture.

Future research should consider expanding this model to other regions in the Philippines, thereby gaining a broader understanding of the challenges and opportunities associated with QMS implementation in higher education. Such research will contribute to the ongoing development of effective quality management practices, ensuring that educational institutions can thrive in an increasingly competitive landscape.

REFERENCES

- Felix Jr, T., et al. (2020). The role of quality management systems in educational institutions. *Philippine Journal of Education*.
- Garcia, L. (2013). Leadership in quality management. *Journal of Educational Leadership*.
- Marmar, J. (2020). Employee engagement and quality control: A review. *Management Insights*.
- Koskela, L., et al. (2019). Value generation theory in quality management. *International Journal of Quality Studies*.
- Andres, R. (2019). Assessing QMS practices in educational institutions. *Journal of Institutional Management*.
- Barbadia, P., & Haguisan, R. (2020). The impact of QMS on employee engagement. *Journal of Quality Assurance*.
- Harivelle Ligaya, C., & Zalamea, M. (2015). Employee engagement in Philippine SUCs. *Philippine Education Review*.
- Dasig Jr, D., et al. (2017). Monitoring and evaluation of QMS in SUCs. *Asian Journal of Quality Studies*.
- Silva, P., et al. (2021). Leadership in quality management: A systematic review. *Journal of Leadership and Quality*.
- Lobo, A. (2023). The future of employee engagement in higher education. *International Journal of Human Resources*.
- Hussein, S., et al. (2018). Implementation challenges of ISO 9001 in higher education. *Journal of Educational Standards*.
- Amabile, T. (2021). Enhancing employee engagement through recognition. *Journal of Management Development*.
- Kahn, R. (2020). Cross-cultural studies in employee engagement. *International Journal of Business Research*.
- Edralin, D. (2021). The mediating role of employee engagement in performance. *Organizational Psychology Review*.
- Chandra, T., et al. (2019). Client feedback mining in educational institutions. *Educational Technology Journal*.

PENOMENOLOHIKAL NA PAGSUSURI SA INTERKULTURAL NA DANAS NG MGA FILIPINO VIRTUAL ASSISTANT SA INTERNATIONAL COMPANY: BASEHAN SA PAGBUO NG INTERCULTURAL COMMUNICATION TRAINING PROGRAM

Joseph C. Anggot

KALIGIRAN NG PAG-AARAL

Kasabay ng pag-usad ng panahon ang kaliwa't kanang pagsulputan ng mga *digital business*. Bunsod ito ng globalisasyon na kung saan napadali at napabilis ang kalakalan gamit ang mga *digital technology* (Libai et. al, 2020). Kaugnay nito, sa pamamayagpag ng nasabing negosyo, nagluwal naman ito sa pangangailangan ng *human virtual assistant*.

Ang human virtual assistant (HVA) ay isang *remote self-employed worker* na nagtatrabaho upang magbigay ng serbisyo sa mga kliyente. Siya ang namamahala sa iba't ibang mga Gawain tulad ng pag-aayos ng mga *appointment*, pagsagot ng tawag sa telepono o pagtugon sa email ng kustomer, pagi-iskedyul ng biyahe, pangangasiwa sa mga *social media account* at iba pa (Wastermorelan, 2023).

Ayon kay Uelson (2020), isa sa pinakabenepisyo ng pagkakaroon ng HVA ay ang pagbibigay daan sa mga kumpanya na mapataas ang produktibidad ng kanilang negosyo sa pamamagitan nang pagbibigay rito ng mga gawaing paulit-ulit at nangangailangan nang mahabang oras sa paggawa. Sa pagpasa ng mga nasabing gawain sa HVA, nagagawang makapokos ng mga kompanya sa mahahalagang proyekto na makatutulong upang mapalago at mapalawak pa ang kanilang negosyo.

Ang Pilipinas ang isa sa mga nangungunang probayder ng HVA sa *outsourcing industry*. Tinuturong dahilan ni Batilong (2022) ay ang pagiging matatas sa Ingles ng karamihan sa mga Pilipino. Noong 2023, ang Pilipinas ay nasa ikalabing-walong (18th) pwesto sa mga bansa sa mundo at pangalawa (2nd) naman sa Asya pagdating sa English Proficiency Index. Maliban sa kahusayan sa nasabing wika, tinuturo ding dahilan ni Batilan ang mataas na literacy rate ng mga Pilipino. Sa tala ng PSA (2023), 97.0% ang naitalang literacy rate sa bansa. Nangangahulugan ito na kapag tumanggap ka ng Filipino HVA, makatitiyak na makakakuha ka ng empleyadong maalam at may mahusay na kasanayan sa pakikipatalastasan. Ayon kay Batilan, karagdagan bonus pa sa nabanggit ang pagkakaroon ng kaalaman ng mga HVA sa Pilipinas hinggil sa daynamiks ng *outsourcing*, bagay na malaking tulong sapagkat may ideya na sila sa kalikasan ng trabahong ipapagawa sa kanila.

Hindi matatawaran ang husay ng mga HVA sa ating bansa. Kaya naman nakababahala ayon kay Linog (2023) na sa mundo ng *virtual assistance*, nagkakaroon ng penomenon ng biglang pagkunti ng mga Pilipinong HVA. Tinuturong dahilan ni Linog ang mga sumusunod: 1) komitment sa pamilya; 2) pagkakaiba ng time zone; at 3) alok ng magandang oportunidad.

Sa ginawang pag-aaral ni Simoy (2022), binanggit nito na ang interkultural na salik ang siyang pangunahing dahilan ng pag-iba ng karera ng karamihan sa mga Pilipinong HVA. Sa tesis ni Simoy, natuklasan nito na ang kaibahan ng kultura o balyus ng mga Pilipino HVA sa kanilang kliyente ay nagiging mitsa ng hindi pagkakaunawaan, na madalas mauwi sa paghinto nila sa ganitong trabaho. Kaugnay nito, sa ganitong tagpo pumapasok ang pag-aaral na ito. Layunin nitong masuri ang interkultural na danas ng mga Pilipino sa pagiging HVA sa international company. Mula rito, bubuo ang mananaliksik ng *intercultural communication training program* na makatutulong sa mga Filipino na nagbabalak maging HVA, lalo na sa international company.

Mga Layunin

Pangunahing layunin ng pananaliksik na ito na makabuo ng *intercultural communication training program* para sa mga Pilipinong nagnanais maging HVA. Kaugnay nito, layon ng pananaliksik na sagutin ang mga sumusunod na tanong:

- 1) Ano-ano ang mga karanasang nagsasalarawan sa interkultural na danas ng mga Pilipino HVA sa pakikipagtransaksyon sa mga dayuhang kliyente?
- 2) Ano ang *intercultural communication training program* ang maaaring imungkahi sa mga Pilipinong nagnanais maging HVA sa international company?

PAMAMARAAN

Isang kwalitatibong pananaliksik ang ginamit ng mananaliksik sa kanyang pag-aaral. Binanggit nina Corbin at Strauss (na binanggit sa pag-aaral ni Khan, 2014) na sa paggawa ng ganitong uri ng pananaliksik, nangangahulugan ito ng pagpasok sa mundo ng mga kalahok at suriin ito mula sa kanilang perspektibo. Kaugnay nito, penomenolohikal naman ang uri ng kwalitatibong disenyong ginamit ng mananaliksik. Transidental (Transcedental) ito na kung saan ang mananaliksik ay sinuri ang karanasan ng mga kalahok ng walang halong pagkiling. Isinakatuparan ito sa pamamagitan ng pagsasagawa ng *epoche* o *bracketing*. Ayon kay Moustakas (1994), isa itong pamamaraan ng pagsantabi sa paunang opinyon o saloobin sa isang penomena. Sa pananaliksik na ito, may sapantaha ang mananaliksik na mahirap magtrabaho bilang HVA sa international company. Ang sapantahang ito'y nagmula sa mga literaturang nabasa niya hinggil sa HVA. Ganunpaman, tiniyak niyang hindi makaapekto ito sa kanyang pangangalap ng datos. Naisakatuparan ito sa pamamagitan ng pagdisenyo ng mga tanong na neutral. Halimbawa, imbes na itanong na- *Gaano kahirap maging HVA sa mga dayuhang kliyente?* Nirebisa ito at naging- *Anong naging karanasan mo sa pagiging HVA sa mga dayuhang kliyente?*

Sa pangangalap naman ng mga kalahok ng pag-aaral na ito, binigyang imibitasyon (via e-mail) ang mga kasalukuyang mag-aaral ng mananaliksik na nagtatrabaho bilang HVA sa *international company*. *Convenience sampling* ang pamamaraang ginamit sa pagpili ng kalahok. Ayon kina Ochave et al. (1998), angkop na gamitin ang *sampling* na ito sa ganitong sitwasyon sapagkat nagiging kumbyente ito sa panig ng mananaliksik. Hindi niya na kailangang maghagilap pa ng mga kalahok sapagkat may mga mag-aaral naman siyang pasok sa krayteryang hinahanap niya. Kaugnay nito, limang (5) kasalukuyang mag-aaral ng mananaliksik ang siyang nagging kalahok.

Sa pagtatangkang tuklasin ang danas ng mga kalahok bilang HVA sa international company, gumamit ang mananaliksik ng Focus Group Discussion (FGD). Angkop itong gamitin upang makakalap ng datos sa iba't ibang indibidwal na kung saan tinatalakay ang perspektibo, opinyon, paniniwala at atityud ng mga kalahok (Onwuegbuzle, Dickinson, Leech & Zoran, 2009). Kaugnay nito, ang mga tanong sa FGD na siyang magsisilbing lunsaran sa pagtatanong ay hinati sa dalawa. Una, ang *introductory questions* na ang layunin ay magtaguyod ng magandang relasyon sa pagitan ng mga kalahok at mananaliksik. Halimbawa nito ay ang: 1) *Anong account ang hawak mo?* At 2) *Ilang taon ka ng HVA sa kumpanyang iyong pinapasukan?* At ang huli, ang *exploratory questions* na ang layunin naman ay bigyang kalayaan ang mga kalahok na ibahagi ang kanilang danas bilang HVA sa international company na kanilang pinapasukan. Binubuo naman ito ng mga sumusunod na tanong: 1) *Anong interkultural na danas mo sa pakikipagtransaksyon sa mga dayuhang kliyente?* 2) *Ano ang kaibahan ng pagiging HVA sa local*

na kliyente sa dayuhang kliyente? At 3) Anong interkultural na kahandaan ang maipapayo mo sa mga nagnanais pasukin ang pagiging HVA sa international company?

Ang mga datos na nakalap ay lalagumin sa pamamagitan ng pagbuo ng tema (theme). Ito ang magsisilbing interpretasyon hinggil sa naging danas ng mga kalahok. Ito rin ang magiging batayan sa pagbuo ng balangkas ng mungkahing *intercultural communication training program*.

RESULTA AT DISKUSYON

Inilalahad sa bahaging ito ang resulta at interpretasyon ng mga datos batay sa ginawang pagsagot sa mga inilalahad na layunin.

Ano ang interkultural na danas mo sa pakikipagtransaksyon sa mga dayuhang kliyente?

Sa naganap na FGD, naitala ang naging tugon ng mga kalahok na siyang nagsasalarawan sa kanilang naging paglalakbay sa mundo ng HVA. Batay rito, lumitaw ang ilang mga temang tumutukoy sa kanilang naging karanasan.

Talahanayan 1 Pagsasalarawan sa Danas ng Pagiging HVA sa International Company

Tema	Tugon ng Kalahok
Fleksibol ang gawain	<p>“Kumportable kasi naka-work from home ang set up ko. Iwas traffic. Kahit saan pwede ako magwork.”</p> <p>“Nakakapili ako ng isked na swak sa schedule ng klase ko.”</p> <p>“Magaan naman kasi iyong administrative task, kaya naman naiisingit pa rin naman ang bebe time sa gabi, hehehe!”</p>
Mahusay na Komyunikeytor	<p>“Ang mga foreign client ay direct to the point. Kapag may pinagawa sila, isang bagsakan nilang ibibigay sa iyo ‘yon. Compare sa dati kong local company, pasundot-sundot ang mga task. Iyong tipong malapit na matapos ang shift mo, may biglaang ipapagawa”</p> <p>“Malinaw ang instruction ng mga task na pinapagawa ng mga foreign client. Step by step kasi nilang ipapaliwanag sa’yo.”</p>
Mapaghamong Kultura	<p>“Karamihan sa mga kliyente ko ay may iba’t ibang cultural background, kaya challenging minsan ang makipagtransaksyon sa kanila. Partikular na ang mga client na hindi masyadong fluent sa Ingles. Kaya ang advice ko, it’s important to make time to understand your client’s language and culture.”</p> <p>“Batay sa karanasan ko, demanding na client ang mga Pilipino. Iyong tipong di pa nga deadline, kukulitin ka para sa update. Wala naman sanang problema roon, kaso, magri-request ng mga rebisyon, buti sana minor, eh ang madalas, major revision. Sa current boss ko ngayon na Australian, di sila makulit. Ginagalang nila ang deadline na napagkasunduan.”</p> <p>“Strict sa deadline ang mga foreign client. Attention to details din sila kaya marapat maging busisi sa gawa. Kailangan ding you are willing to learn new skills, kasi ini-expect nila na multi-tasker ka. Pero mataas naman sila magpasahod kaya oks lang din.”</p>

Makikita sa Talahanayan 1 na karamihan sa mga kalahok ay nagpakita ng positibong opinyon hinggil sa pagiging HVA sa *international company*. Ayon sa ilang kalahok, ito ay dahil na rin sa magandang naging karanasan nila sa pakikipagtrabaho sa kanilang *foreign client*. Pagbabahagi ni Kalahok 1, “*Ang mga foreign client ay direct to the point. Kapag may pinagawa sila, isang bagsakan nilang ibibigay sa iyo ‘yon.*” Ito ang dahilan kung bakit maaga nilang natatapos ang kanilang gawain. Dagdag naman dito ni Kalahok 2, “*Malinaw ang instruction ng mga task na pinapagawa ng mga foreign client. Step by step kasi nilang ipapaliwanag sa’yo.*” Ayon kay Plasschaert (2024), ang kalinawan ng instruksyon ay lubhang nakatutulong upang matapos ang gawain nang tama, konsistent, at mabawasan ang tsansa na magkaroon ng mali. Sa madaling salita, pinapabilis nito ang proseso ng paggawa dahil na rin sa *step-by-step instructions*.

Tinuran naman ni Kalahok 3 na ang pagiging “fleksibol ng gawain” ang siyang agustuhan niya sa pagiging HVA sa *international company*. Pagbibida niya, “*Kumportable kasi naka-work from home ang set up ko. Iwas traffic. Kahit saan pwede ako mag-work.*” Ayon naman kay Kalahok 2, ang pagiging maluwag sa iskedyul ang siyang nagustuhan niya sa trabahong ito. Aniya, “*Nakakapili ako ng isked na swak sa schedule ng klase ko.*” Kaugnay nito, sinabi ni Stich (2020) na ang pagiging fleksibol ng trabaho ay nagdudulot ng atraksyon sa mga *job seeker*. Pinatotohanan ito mismo ng kanyang pag-aaral na pinamagatang “*Flexible working and applicant attraction: a person-job fit approach*”.

Sa naging panayam ng mananaliksik sa mga kalahok, ang pagiging mapaghamon ng kultura ang siyang nakitang pangunahing hamon sa pagiging HVA sa *international company*. Paliwanag ni Kalahok 4, “*Karamihan sa mga kliyente ko ay may iba’t ibang cultural background, kaya challenging minsan ang makipagtransaksyon sa kanila.*” Mungkahi naman ni Kalahok 4 sa bagay na ito, kinakailangang maglaan ng oras na pag-aralan ang kultura ng kilyente, lalo na pagdating sa paggawa. Tinuran naman ni Kalahok 5 na maigi kung *muliti-tasker* ka nang sa gayon ay magustuhan ka ng mga *foreign client*. May mga pagkakataon kasi na nagpapagawa sila na labas na sa kasanayang mayroon sa isang HVA. Ayon kay Kalahok 5, “*Kailangan ding you are willing to learn new skills.*” Ang pahayag na ito ay sinusuportahan ni Calanas (2023). Aniya, “*Sa kasalukuyan, ang role ng isang human virtual assistant ay hindi lamang tungkol sa paggawa mga admin support task- pag-schedule ng appointment at pagsagot sa mga email. Kinakailangan maalam din siya kahit dalawa o tatlo sa mga sumusunod na role: project coordinator, social media manager, basic graphic designer, customer-relationship manager, at research and data analyst.*”

Ano ang intercultural communication training program ang maaaring imungkahi sa mga Pilipinong nagnanais maging HVA sa international company?

Isang *intercultural communication training program* ang iminungkahi ng mananaliksik upang matulungan ang mga mag-aaral ng Eulogio Amang Rodriguez Institute of Science and Technology (EARIST) na nagnanais pasukin ang larang na ito. Nakabatay ang nasabing programa sa naging karanasan ng mga kalahok na lumitaw sa mga sumusunod na tema: fleksibol na gawain, mahusay na komyunikeytor, at mapaghamong kultura.

Sa pagdisenyo ng *intercultural training program*, isinaalang-alang ng mananaliksik ang henerasyong kinabibilangan ng mga target na kalahok ng training na ito. Sila ay nabibilang sa Gen Z. Ang ganitong uri ng mga kalahok ay higit na natuto kung inuugnay ng guro sa tunay na buhay ang mga kasanayang itinuturo (Novotney, 2004). Ayon kay Price (2009), ang mga ganitong uri ng mga kalahok ay ayaw ng *lecture discussion* sa *training*. Mas gusto nila ang *experiential learning*. Kaugnay nito, tinuran ni Fink (2013) na ang paglahok ng *activity* o gawain sa *training* ay hindi lamang nakababawas ng kanilang pagkabagot bagkus nakakapagpataas din

ng kalidad ng kanilang pagkatuto. Dahil dito, sa dinisenyong *intercultural communication training program*, inilakip niya ang *workshop* at *job shadowing* bilang gawain. Makikita sa ibaba ang kabuoang disenyo ng *training program* ng mananaliksik.

Mungkahing Intercultural Training Program: Paghahanda sa Pagiging Human Virtual Assistant sa International Company

Deskripsyon ng Program

Ang *training program* na ito ay hinango mula sa konsepto ng *experiential learning theory* na kung saan binigyang kahulugan nito na ang pagsasanay ay isang proseso at ang kaalaman ay nabubuo sa pamamagitan ng pagbabago ng karanasan (Kolb, 2015). Ito ay binubuo ng mga aktibidad na iminungkahi ng mga eksperto: *seminar*, *workshop*, *job shadowing* at *leadership training*. Makikita sa Talahanayan 2 ang *activity matrix* ng *training program* na naglalaman ng mga impormasyon hinggil sa mga gawain maghahanda sa mga mag-aaral na maging epektibong *human virtual assistant* sa *international company*.

Talahanayan 2
Activity Matrix ng Intercultural Training Program

Mga Layunin	Gawain	Kagamitan	Saklaw ng Oras	Nga Taong Kasangkot	Inaasahang Awtput
Magbahagi ng mga kwento ng danas sa pagiging HVA sa <i>international company</i> .	<i>Seminar</i>	<i>Microphone at laptop</i>	4 oras	3 HVA speaker Mag-aaral ng EARIST	Magkakaroon ng malawak na kaalaman ang mga mag-aaral hinggil sa mundo ng pagiging HVA.
Magawang mamuno at makipaguganayan sa iba't ibang uri ng tao o lahi.	<i>Leadership training</i>	<i>Laptop</i>	1 araw / 8 oras	<i>Resource Speaker</i> <i>Guidance Counselor</i> Mag-aaral ng EARIST	Malaman ang mga epektibong pamamaraan sa pamumuno at pakikipagugnayan sa tao. Mabatid kung paano lalagpasan ang mga mahihirap na sitwasyon.
Malinang ang mga sumusunod na kasanayan- <i>administrative, marketing, sales, customer support, design at finance</i>	<i>Workshop</i>	<i>Laptop</i>	1 araw / 8 oras	3 HVA speaker Mag-aaral ng EARIST	Matagumpay na maisakatuparan ang mga gawaing may kaugnayan sa <i>administrative, marketing, sales, customer support, design, at finance</i> .
Maranasan ng aktwal ang pagiging HVA sa <i>foreign client</i> .	<i>Job shadowing</i>	<i>Laptop</i>	1 araw / 8 oras	HVA mentor Mag-aaral ng EARIST	Magkaroon ng karanasan sa pagiging HVA sa <i>international company</i> .

KONGKLUSYON

Kaugnay sa naging resulta ng pananaliksik, nabuo ang mga sumusunod na kongklusyon:

1. Lumalabas na ang mga kalahok ay nagpakita ng positibong atityud sa pagiging HVA. Ito ay dahil sa kanilang naging magandang karanasan sa pakikipagtrabaho sa mga *foreign client*. Nariyan na nagustuhan nila ang mga sumusunod: pagiging fleksibol ng gawain, *direct to the point* ng kilyente, at pagbibigay nito ng malinaw na *instruction* at mataas na sahod.
2. Ang mungkahing gawain sa *intercultural training program* ay hinalaw naging tema ng tugon ng mga kalahok. Ito ay binubuo ng mga sumusunod: fleksibol na gawain, mahusay na komyunikeytor, at mapaghamong kultura. Mapapansin na ang gawaing ito ay naglalayong matutunan ng mga mag-aaral ang aktwal na kalakaran ng pagiging HVA sa *international company*.

REKOMENDASYON

Kaugnay sa naging resulta at onklusyon ng pananaliksik, nabuo ang mga sumusunod na rekomendasyon:

1. Maaaring gumamit ng iba pang disenyo ng pananaliksik sa pagtukoy sa danas ng mga Pilipino sa pagiging HVA sa mga *foreign client*.
2. Maaring gamitin ang balangkas ng *intercultural training program* na ito bilang gabay sa pagbuo ng katulad din nitong programa.
3. Maaring palawigin pa ang pananaliksik na ito sa pamamagitan ng pagsuri naman sa intercultural na danas ng mga foreign client sa pagkakaroon ng Pilipinong HVA.

SANGGUNIAN

- Batlong, J. (2019). *Why you should hire a filipino virtual assistant*. Linked in. https://www.linkedin.com/pulse/why-should-you-hire-filipino-virtual-assistant-jaloubati-long?trk=public_profile_article_view.
- Calanas, A. (2023). *10 must have the skills of a virtual assistant*. Outsourcing Angel. <https://outsourcingangel.com/10-must-have-skills-of-a-virtual-assistant/>.
- Fink, L. D. (2013). *Creating significant learning experiences: An integrated approach to designing college courses*. John Wiley & Sons.
- Khan, S. (2014). *Qualitative research method: Grounded Theory*. International Journal of Business and Management, 2 (14), 45-61.
- Kolb, D. (2015). *Experiential learning theory*. Pearson Education Inc.
- Libai, B. et. al. (2020). *Brave new world? On ai and the management of customer relationships*. Journal of Interactive Marketing, 51, 44-56.
- Linog, A. (2023). *Why do filipino virtual assistants disappear? Unveiling the challenges and solutions*. Medium. <https://medium.com/@albert.linog/why-do-filipino-virtual-assistants-disappear-unveiling-the-challenges-and-solutions-47d0c30e49a5>.
- Novotney, A. (2014). *Engaging the millennial learner*. American Psychological Association.
- Onwuegbuzie, A. et. al. (2009). *A qualitative framework for collecting and analyzing data in focus group research*. International Journal of Qualitative, 2 (31), 34-41.
- Plasschaert, B. (2024). *The importance of work instructions*. Azumuta. <https://www.azumuta.com/resources/blog/the-importance-of-work-instructions-and-howto-write-them/>.
- Price, C. (2009). *Why don't my students think I'm groovy? The new "R"s for engaging millennial learners*. The Teaching Professors.
- Simoy, L (2022). *Dramaturgical framing of 'va hyping' as impression management: An autoethnographic study of filipino virtual assistant practitioner*. University of The Philippines Press. <https://api.repository.upou.edu.ph/api/core/bitstreams/0669d88f-5ec1-4269-83e4-f6204c57e4b7/content>.
- Stitch, J. (2020). *Flexible working and applicant attraction: A person job fit approach*. Emerald Publishing. 50 (1), 358-378. https://www.researchgate.net/publication/342899664_Flexible_working_and_applicant_attraction_a_person-job_fit_approach.
- Wastemoreland, A. (2023). *The rise of human virtual assistant: How they are transforming business and everyday life*. Linked in. <https://www.linkedin.com/pulse/rise-human-virtualassistants-how-transforming-life-westmoreland>.

EXPLORING THE INFLUENCE OF STEM EDUCATION ON COLLEGE STUDENTS: AN ACTION RESEARCH

Daisy Mae R. Bongtiwon

Benjamin G. Haboc

Elsa R. Cagatan

Eleonor T. Salvador

INTRODUCTION

In recent years, there has been a growing emphasis on the enhancement of STEM (Science, Technology, Engineering, and Mathematics) education, driven by the need to prepare students for the challenges of an increasingly technology-driven society. STEM education not only fosters critical thinking and problem-solving skills but also nurtures innovation and creativity. Recognizing its significance, various initiatives and programs have been implemented to integrate STEM into both formal and informal learning settings.

The emphasis on STEM education has grown significantly in recent years, driven by the need to prepare students for an increasingly technology-driven society. STEM education integrates science, technology, engineering, and mathematics, emphasizing hands-on, inquiry-based learning to develop critical thinking, problem-solving, and collaboration skills. However, many college students face challenges in STEM-related courses, leading to low enrollment rates and hindered academic success. Several studies in the Philippines have highlighted obstacles such as course difficulty, socio-cultural factors, and individual mindsets affecting STEM education.

Many college students are having difficulty in their STEM-related courses. The challenges posed by the perceived difficulty of STEM courses and subsequent low enrollment rates represent significant hurdles in higher education (Sithole, 2017). Several studies have shed light on the multifaceted challenges within STEM education in the Philippines. Jr. (2021) outlined course-related, individual, and socio-cultural obstacles encountered by high school students, while Sidek (2023) delved into the reasons behind course mismatches among former STEM students, citing the perceived difficulty of STEM subjects. Alinsunurin (2021) emphasized the influence of socioeconomic backgrounds and learning mindsets on academic achievement, particularly in science and mathematics. Additionally, Toma (2020) highlighted the correlation between the perceived difficulty of school science and the advancement of cost in STEM education.

With numerous challenges hindering the success of students in STEM-related courses, there is a pressing need to address these obstacles and cultivate an environment conducive to learning success in STEM fields. The proposed integration of AI into classroom instruction offers promising opportunities to overcome these challenges by providing personalized learning experiences and enhancing student engagement and comprehension.

By implementing this approach in Philippine schools, the project aims to contribute to the advancement of STEM education and ultimately support the development of a highly skilled workforce capable of meeting the demands of a rapidly evolving global economy. Additionally, the emphasis on practical implementation ensures that the project's findings translate into tangible benefits for students, educators, and educational institutions, thereby fostering a culture of innovation and excellence in STEM education in the Philippines.

METHODOLOGY

The study aimed to qualitatively explore the perspectives of college students on STEM education. A total of 173 freshmen college students under BSIT and BSE Programs of EARIST-Manila, comprising both STEM and Non-STEM SHS graduates, participated in the survey. The survey sought to assess the level of awareness among students regarding STEM education and its associated benefits.

Ten (10) questions about STEM education were posed during interviews and focus group discussions (FGD) among college students. Subsequently, the results are translated into themes for interpretation. The discussion of results utilized thematic analysis to extract information from the answers provided by the students.

RESULTS & DISCUSSION

The findings of the survey highlighted various initiatives aimed at promoting STEM education. These initiatives included extension activities in local communities, seminars for pre-service teachers, and webinars to raise awareness about the significance of STEM. These efforts aimed to engage both students and educators, emphasizing the practical applications and societal relevance of STEM disciplines. Collectively, these findings underscore the necessity for targeted interventions to address the challenges and bolster enrollment rates in STEM courses across the Philippines.

Definition of STEM education According to College Students

STEM education encompasses an interdisciplinary approach to learning, integrating science, technology, engineering, and mathematics. It emphasizes real-world applications and critical thinking skills, preparing students for careers in these fields. The curriculum typically includes complex mathematical and scientific concepts and fosters skills essential for various fields. STEM education is challenging but beneficial, offering opportunities for students to develop problem-solving abilities and delve into subjects like chemistry and physics.

The responses highlight different aspects of STEM education, with a common understanding that it revolves around science and mathematics. Participants acknowledge the challenging nature of STEM subjects, noting the emphasis on critical thinking and problem-solving skills. Some express the belief that STEM education is important for preparing students for future careers and for understanding the world around them.

The findings underscore the interdisciplinary nature and importance of STEM education in preparing students for future careers and tackling real-world challenges, aligning with previous research. Gonzalez (2012) highlights college students' perception of STEM education involving science and mathematics instruction across various academic levels and educational settings. Similarly, Popa (2017) corroborates this perspective by noting students' early interest in STEM disciplines and their reliance on educators' guidance when selecting majors.

Importance of STEM Education for Philippine Development

The importance of STEM education for the overall development of a country like the Philippines is widely recognized among respondents. STEM education is seen as crucial for fostering innovation, technological advancement, economic growth, and global competitiveness. It equips individuals with essential skills in science, technology, engineering, and mathematics, promoting critical thinking, problem-solving, and decision-making abilities.

Moreover, STEM education is viewed as instrumental in addressing societal challenges, preparing a future-ready workforce, and strengthening connections with countries with robust economies.

Responses overwhelmingly emphasize the significance of STEM education in driving the overall development of the Philippines. Many highlight its role in fostering innovation, economic growth, and global competitiveness, stressing the importance of a skilled STEM workforce in today's competitive landscape. Additionally, STEM education is viewed as essential for addressing societal challenges and preparing individuals for the rapidly evolving demands of the future. The sentiment is that investing in STEM education is crucial for the country's prosperity and sustainability, positioning it as a leader in innovation and development. Overall, respondents believe that prioritizing STEM education is essential for the advancement and progress of the Philippines.

Both the results of this study and Silva (2020) stress the vital role of STEM education in the Philippines' development, emphasizing its contribution to innovation, economic growth, and global competitiveness. While the responses focus on broader societal and economic impacts, Silva specifically highlights skills like problem-solving, teamwork, and presentation abilities as outcomes of STEM education. Additionally, Silva notes a research gap concerning STEM education's specific impact on the Philippines' educational system and overall development, indicating the need for further exploration. Overall, both perspectives align in advocating for the prioritization of STEM education to advance the Philippines' progress.

The Level of Emphasis on STEM education in the Philippines

Opinions vary regarding whether there is currently enough emphasis on STEM education in the Philippines. Some respondents believe that STEM education is receiving adequate attention, citing the government's recognition of its importance and the increase in STEM-related initiatives in recent years.

However, challenges such as limited resources, infrastructure, and teacher expertise still exist, suggesting that more emphasis is needed. Others highlight the crucial role of STEM in national development, emphasizing the need for stronger connections between science, industry, and technology. However, concerns remain about the accessibility of STEM education, especially in rural areas and provinces, where schools may not offer STEM strands.

Responses reflect a mixed perspective on the emphasis placed on STEM education in the Philippines. While some acknowledge the efforts made by the government and the increasing recognition of STEM's importance, others highlight persistent challenges such as resource limitations and unequal access to STEM education. There is a consensus among respondents about the crucial role of STEM in national development, particularly in advancing industry, technology, and the economy. However, concerns about the accessibility and quality of STEM education persist, indicating a need for further improvement and investment in this area. Overall, respondents suggest that while progress has been made, more attention and resources are required to ensure that STEM education adequately prepares students for the challenges of the future.

Both the results of this study and the studies by Liu (2014), Maltese (2011), Kennedy (2014), and Xie (2015) underscore the significance of STEM education in the Philippines, highlighting its role in national development. While respondents acknowledge government efforts in STEM education, echoing global concerns raised by Liu (2014), Maltese (2011) and Kennedy (2014) stress the pivotal influence of early interest in mathematics and science on students' decisions to pursue STEM degrees, emphasizing the need for robust curriculum and teacher

training. Additionally, Xie (2015) sheds light on persistent disparities in STEM education due to social and psychological factors.

Together, these sources advocate for a holistic approach to STEM education, integrating curriculum improvements with socio-psychological interventions to ensure equitable access and quality education.

Potential benefits of STEM education to society

STEM education offers various benefits to individuals and society, including fostering critical thinking, problem-solving skills, and technological literacy. It provides a foundation for personal and societal advancement by preparing individuals for diverse career opportunities and driving innovation and economic growth. STEM education encourages active analysis and evaluation of knowledge to solve complex problems, contributing to individual growth and societal progress.

The responses highlight the multifaceted benefits of STEM education for both individuals and society. They emphasize the development of critical thinking

skills, problem-solving abilities, and technological literacy essential for navigating today's complex world. Additionally, STEM education is recognized for its role in driving innovation, economic growth, and societal progress. By equipping individuals with knowledge and skills in STEM fields, it enables them to contribute to solving real-world challenges and advancing society as a whole. Overall, the consensus among respondents is that STEM education brings significant benefits to both individuals and society, making it a crucial component of education.

While the study provides a broad overview of STEM's benefits, Walker (2013) focuses on its impact on worker productivity and income levels, Mildenhall (2021) on its relevance for global challenges, Widya (2019) on its significance for competitiveness, and Drew (2020) on its role in economic productivity and social justice, particularly in the digital era. Together, they underscore STEM education's transformative potential, albeit from varying angles.

Challenges of promoting and implementing effective STEM education in the Philippines

The Philippines faces various challenges in promoting effective STEM (Science, Technology, Engineering, and Mathematics) education, including inadequate funding, infrastructure limitations, teacher shortages, and a lack of engagement from students and communities. These challenges impact both STEM and non-STEM perspectives, highlighting the need for collaborative efforts to address the gaps in resources, curriculum development, and teacher training. Despite the importance of STEM education for societal progress, hurdles such as financial constraints, outdated facilities, and limited access to technology hinder its effective implementation.

The responses underscore the multifaceted challenges hindering the promotion and implementation of effective STEM education in the Philippines. These challenges include inadequate funding, infrastructure limitations, teacher shortages, and a lack of interest and engagement from students. Moreover, there are concerns about outdated facilities, limited access to technology, and the need for collaborative efforts from various stakeholders to address these issues. The responses also highlight the importance of practical, hands-on learning experiences and the need for a curriculum that is relevant to students' lives and future careers.

The present study highlights the complex challenges in effective STEM education in the Philippines. Similarly, Jr. (2021) identifies course difficulty, individual mindsets, and socio-cultural factors as hurdles faced by high school students, proposing policy changes. Talaue (2014) stresses social equity and private sector partnerships, while Mustafa (2016) suggests project-based learning. Chong (2019) provides insights from Malaysia, applicable to the Philippine context. Overall, both the study and the references call for diverse strategies to effectively address the challenges in STEM education.

Specific challenges related to gender and socioeconomic status in STEM Education

Gender disparities, socioeconomic inequalities, and regional discrepancies pose significant challenges to achieving equitable access and participation in STEM (Science, Technology, Engineering, and Mathematics) education in the Philippines. Women and girls are often underrepresented in STEM fields due to gender biases and stereotypes, while students from lower socioeconomic backgrounds may face barriers such as limited access to resources and quality education.

Additionally, regional differences can result in unequal distribution of STEM resources and opportunities, particularly in rural and remote areas. Addressing these challenges requires inclusive policies, targeted support, and efforts to promote representation and diversity in STEM education.

The responses highlight the multifaceted challenges related to gender, socioeconomic status, and regional disparities in STEM education in the Philippines. Gender biases and stereotypes contribute to the underrepresentation of women in STEM fields, while socioeconomic inequalities create barriers to accessing quality STEM education for students from disadvantaged backgrounds.

Moreover, regional differences in infrastructure and resources further exacerbate these disparities, particularly in rural areas. Efforts to address these challenges include implementing inclusive policies, providing equal opportunities, and fostering a supportive and diverse learning environment.

Both the study's responses and some studies highlight challenges in gender, socioeconomic status, and regional disparities in STEM education. They note stereotypes and biases perpetuating women's underrepresentation in STEM, echoing Botella (2019) and Pathak (2022). Chavatzia (2017) underscores sociocultural and economic factors affecting girls' participation, while Casad (2020) emphasizes the need for inclusive policies and supportive environments. Both sources advocate for promoting female role models and implementing organizational changes to address these disparities comprehensively.

The role of the government in promoting STEM education, and how might this differ between

STEM and non-STEM fields.

The government plays a significant role in promoting STEM (Science, Technology, Engineering, and Mathematics) education, especially in allocating resources, shaping policies, and fostering an environment conducive to STEM learning. In STEM fields, this involvement often includes funding for specialized programs, partnerships with industry, and initiatives to enhance infrastructure. Conversely, in non-STEM fields, the focus may be more on general education policies and workforce development, with less emphasis on specialized technical skills. The goal is to ensure a well-rounded education that meets the demands of a diverse job market while recognizing the unique requirements of STEM disciplines.

The responses provide various perspectives on the role of the government in promoting STEM education and how it may differ between STEM and non-STEM fields. Many acknowledge the government's crucial role in allocating resources, developing curriculum standards, and supporting research initiatives to advance STEM education. There's also recognition of the government's focus on encouraging young people to pursue STEM through scientifically grounded promotion. However, some express concerns about the disparity in attention between STEM and non-STEM fields, emphasizing the need for comprehensive career seminars and equal support for all educational disciplines. Overall, the responses highlight the complexity of promoting STEM education effectively while ensuring inclusivity and addressing the diverse needs of students.

Both the results of the study and some studies highlight the pivotal role of the government in promoting STEM education, emphasizing resource allocation, curriculum development, and support for research initiatives. While the responses acknowledge the government's efforts in encouraging STEM pursuits among youth through scientifically grounded promotion, concerns are raised regarding the disparity in attention between STEM and non-STEM fields, advocating for comprehensive career seminars and equal support across educational disciplines.

Similarly, Liu (2014) underscores the government's role in advancing STEM education through multidisciplinary projects and teacher training, aligning with the recognition of STEM's importance for national development highlighted by Freeman (2019). However, Wong (2016) suggests a need for further clarification and debate on the meaning and compatibility of STEM education, while Kuenzi (2013) discusses legislative proposals in the United States aimed at enhancing STEM preparedness. Both the responses and the referenced studies emphasize the nuanced approach required in promoting STEM education effectively while addressing diverse student needs and ensuring inclusivity.

Initiatives or policies of the government that enhance STEM education in the Philippines, considering both STEM and non-STEM contexts

Enhancing STEM education in the Philippines requires a multifaceted approach involving government agencies, educational institutions, industries, and the community. Initiatives and policies should prioritize equitable resource allocation, robust teacher training programs, interdisciplinary curriculum development, and promotion of inclusivity and diversity in STEM.

Moreover, public awareness campaigns, partnerships with industry and research institutions, scholarships for disadvantaged students, and supportive government policies are essential for fostering a conducive environment for STEM education.

The responses suggest various initiatives and policies that the government and educational institutions should implement to enhance STEM education in the Philippines. These include curriculum integration, teacher training, infrastructure development, partnerships with industry and research institutions, promotion of inclusivity and diversity, public awareness campaigns, and scholarships for disadvantaged students. There's recognition of the need for equitable resource allocation and support for both STEM and non-STEM fields to ensure holistic skill development and address the diverse needs of students. The responses also emphasize the importance of government support and collaboration among stakeholders to effectively promote STEM education in the country. Overall, the suggestions provide a comprehensive framework for enhancing STEM education and fostering a conducive learning environment for all students.

Comparatively, the study extracts from Patalinghug (2001), Talaue (2014), Wu (2015), and Labov (2009) offer specific insights into the efforts and challenges faced by the Philippines in enhancing STEM education. Patalinghug (2001) focuses on improving science and technology

policies, while Talaue (2014) highlights the government's initiatives to address social equity through the establishment of STEM high schools and scholarships. Wu (2015) emphasizes the integration of technology in STEM education, and Labov (2009) stresses the need for more effective practices in undergraduate STEM education.

Impact of STEM education in the Philippines

Responses vary in terms of personal experiences with STEM education in the Philippines. Some individuals, particularly STEM students, share stories of how STEM education has positively impacted their academic and career aspirations. They mention developing critical thinking, problem-solving skills, and a passion for science and technology. Others, however, express a lack of personal experience with STEM education or share anecdotes about friends or relatives who have benefited from STEM programs. Despite the diverse perspectives, there is a common recognition of the importance of STEM education in fostering skills and opportunities for individuals in the Philippines.

The responses reflect a range of personal experiences and perspectives on the impact of STEM education in the Philippines. Some individuals, particularly those with a background in STEM education, share stories of how it has positively influenced their academic and career paths, citing improved critical thinking skills, passion for science, and access to opportunities in STEM-related fields. Others, who may not have direct experience with STEM education, provide examples of friends or relatives who have benefited from it, highlighting the importance of STEM in driving innovation and providing opportunities for individuals to pursue their passions. Overall, the responses underscore the significance of STEM education in shaping the academic and professional trajectories of individuals in the Philippines.

Comparatively, Jr. (2021) focuses on the challenges faced by high school students in STEM learning, including course-related, individual, and socio-cultural obstacles. Talaue (2014) emphasizes the importance of social equity and access to STEM education, especially for underprivileged students, and advocates for partnerships with the private sector. Añar (2017) provides insights into the learning experiences of Filipino pre-service teachers in a STEM program abroad, highlighting the value of exposure to multicultural classrooms. Vanoy (2022) discusses the role of STEM education in developing 21st-century competencies, particularly through project-based and problem-based learning.

While the first response presents personal anecdotes and perspectives, the subsequent studies offer empirical evidence and analyses of the challenges and opportunities in STEM education in the Philippines. Together, they underscore the multifaceted nature of the impact of STEM education and advocate for a more inclusive and innovative approach to address the identified challenges and capitalize on the opportunities.

CONCLUSION

In conclusion, the findings of this study shed light on the landscape of STEM education in the Philippines, drawing attention to both the challenges and potential avenues for improvement. By examining the experiences of freshmen college students in Senior High School (SHS), we have identified barriers such as course difficulty, gender disparities, and socioeconomic factors that hinder enrollment and success in STEM fields. Moreover, the study highlights the importance of addressing these challenges to create a conducive environment for STEM education.

One notable recommendation emerging from this research is the integration of technology, particularly artificial intelligence (AI), into classroom instruction through the proposed "STEMified Instruction" approach. This underscores the significance of leveraging innovative teaching strategies to enhance STEM learning experiences. Additionally, the study emphasizes

the crucial role of government support and collaborative efforts in advancing STEM education, with proposals for equitable admissions processes, teacher training, and technology integration.

Overall, this research serves as a benchmark for advancing STEM education in the Philippines. By addressing the identified barriers and implementing the recommended initiatives, we can support the success of STEM students and promote broader participation in STEM studies across all educational levels. As we navigate towards a technology-driven future, investing in STEM education is paramount for equipping the next generation with the skills and knowledge necessary to thrive in an increasingly complex world.

RECOMMENDATIONS

The challenges faced by Filipino high school students in STEM learning, encompassing course-related, individual, and socio-cultural obstacles, necessitate a reassessment of educational processes and policies (Jr. 2021). To bridge the gap in access to quality science education, the government has instituted legislative reforms, such as regionalization of admissions and the establishment of a network of science high schools (Talaue 2014). Insights from Filipino pre-service teachers participating in a STEM program in Thailand underscore the significance of experiential, pedagogical, social, multicultural, personal, professional, and technological learning (Añar 2017). Effective practices in undergraduate STEM education, including enhancements in teaching methodologies, learning approaches, assessment strategies, and institutional frameworks, have been developed and implemented in the United States (Labov 2009).

The recommendations from the respondents provided offer a comprehensive strategy for enhancing STEM education in the Philippines, considering the diverse perspectives of both STEM and non-STEM students. They underscore the importance of fairness in entrance exams, advocating for a balanced assessment that considers a range of skills beyond just mathematical proficiency.

Additionally, the significance of inclusivity is emphasized, aiming to cultivate well-rounded individuals equipped to tackle future challenges. Proposed actions include engaging students through outreach programs, bolstering teacher training, investing in STEM resources, and fostering interdisciplinary learning. Priorities also encompass addressing gender and socioeconomic disparities offering career guidance, and harnessing technology, including artificial intelligence.

Moreover, the recommendations focus on curriculum and teacher development, fostering collaboration, and utilizing digital resources and Artificial Intelligence to create a vibrant STEM education ecosystem. Further emphasis is placed on balancing academic and physical activities, conducting seminars for STEM educators, ensuring a supportive learning environment, providing ample resources, and enhancing teaching methodologies.

REFERENCES

- Alinsunurin, J. (2021). Unpacking Underperformance: Learning Mindsets and the Challenge of Academic Achievement Among Filipino Students. *Development Economics: Microeconomic Issues in Developing Economies eJournal*.
- Albarracín Vanoy, R.J. (2022). STEM Education as a Teaching Method for the Development of XXI Century Competencies. *Metaverse Basic and Applied Research*.
- Añar, L.E., Petersen, R., & Villanca, A. (2017). The Learning Experiences of Filipino Pre-service Teachers in the Science, Technology, Engineering and Mathematics (STEM) Program of a Thai Elementary School. *Asia Pacific Journal of Social and Behavioral Sciences*.
- Botella, C., Rueda, S., López-Iñesta, E., & Marzal, P. (2019). Gender Diversity in STEM Disciplines: A Multiple Factor Problem. *Entropy*, 21.
- Casad, B.J., Franks, J., Garasky, C.E., Kittleman, M.M., Roesler, A.C., Hall, D.Y., & Petzel, Z.W. (2020). Gender inequality in academia: Problems and solutions for women faculty in STEM. *Journal of Neuroscience Research*, 99, 13 - 23.
- Chavatzia, T. (2017). Cracking the code: girls' and women's education in science, technology, engineering and mathematics (STEM).
- Chong, C.J. (2019). Preliminary Review On Preparations In Malaysia To Improve Stem Education.
- Drew, D.E. (2020). STEM Education, Economic Productivity, and Social Justice. *Oxford Research Encyclopedia of Education*.
- Freeman, B., Marginson, S., & Tytler, R. (2019). An International View of STEM Education. *STEM Education 2.0*.
- Gonzalez, H.B., & Kuenzi, J.J. (2012). Science, Technology, Engineering, and Mathematics (STEM) Education: A Primer [August 1, 2012].
- Rogayan Jr., D.V., Rafanan, R.J., & De Guzman, C.Y. (2021). Challenges in STEM Learning: A Case of Filipino High School Students. *Jurnal Penelitian dan Pembelajaran IPA*.
- Kennedy, T., & Odell, M.R. (2014). Engaging Students In STEM Education. *Science education international*, 25, 246-258.
- Kuenzi, J.J., Matthews, C.M., & Mangan, B.F. (2013). Science, Technology, Engineering, and Mathematics (Stem) Education Issues and Legislative Options.
- Labov, J.B., Singer, S.R., George, M.D., Schweingruber, H.A., & Hilton, M.L. (2009). Effective practices in undergraduate STEM education part 1: examining the evidence. *CBE life sciences education*, 8 3, 157-61 .
- Liu, J., Feenstra, W., Otero, A.S., & Magrane, K. (2014). STEM Education. *Teaching Elementary STEM Education*.
- Maltese, A.V., & Tai, R.H. (2011). Pipeline persistence: Examining the association of educational experiences with earned degrees in STEM among U.S. students. *Science Education*, 95, 877-907.

- Mildenhall, P., & Cowie, B. (2021). The potential of involving communities to enhance STEM education. *Teachers and Curriculum*.
- Mustafa, N., Ismail, Z.B., Tasir, Z., & Said, M.N. (2016). A meta-analysis on effective strategies for integrated STEM education. *Advanced Science Letters*, 22, 4225-4228.
- Patalinghug, E.E. (2001). An assessment of science and technology policies in the Philippines. *Int. J. Technol. Manag.*, 22, 599-616.
- Pathak, B. (2022). Gender Differences in STEM Education : A Review Study. *Sotang, Yearly Peer Reviewed Journal*.
- Popa, R.A., & Ciascai, L. (2017). S TUDENTS ' A TTITUDE TOWARDS STEM E DUCATION.
- Sidek, M.R., Impil, J.A., Marcos, M.J., Punzalan, E.E., Ramos, J.T., & Ador, Z.I. (2023). Exploring Course Mismatch among Former STEM Students: A Narrative Research. *Cognizance Journal of Multidisciplinary Studies*.
- Mendezcarlo Silva, V., Hernández Peña, S., & Beltrán Saucedo, M. (2020). STEM Education as a Strategy to Move from the New Structural Economy to the Endogenous and Sustainable Growth Model in Latin America. *Labor et Educatio*.
- Sithole, A., Chiyaka, E.T., McCarthy, P., Mupinga, D.M., Bucklein, B.K., & Kibirige, J.S. (2017). Student Attraction, Persistence and Retention in STEM Programs: Successes and Continuing Challenges. *Higher Education Studies*, 7, 46-59.
- Talau, F.T. (2014). Social Equity and Access to a Philippine STEM School. *Theory Into Practice*, 53, 33 - 40.
- Toma, R.B. (2020). Perceived Difficulty of School Science and Cost Appraisals: a Valuable Relationship for the STEM Pipeline? *Research in Science Education*, 52, 553 - 565.
- Walker, I., & Zhu, Y. (2013). The Benefit of STEM Skills to Individuals , Society , and the Economy Report.
- Widya, Rifandi, R., & Laila Rahmi, Y. (2019). STEM education to fulfil the 21st century demand: a literature review. *Journal of Physics: Conference Series*, 1317.
- Wong, V., Dillon, J., & King, H. (2016). STEM in England: meanings and motivations in the policy arena. *International Journal of Science Education*, 38, 2346 - 2366.
- Xie, Y., Fang, M., & Shauman, K.A. (2015). STEM Education. *Annual review of sociology*, 41, 331-357 .
- Стоянова, И., Мавродиева-Кючукова, Д., & Владимирова, И. (2023). STEM ПОДХОДЪТ В ОБУЧЕНИЕТО ПО РЕЛИГИЯ. *Годишник на Шуменския университет. Факултет по хуманитарни науки*.

PRACTICE-TEACHERS' MOTIVATIONAL APPROACH TO STUDENT ENGAGEMENT IN TECHNOLOGY AND LIVELIHOOD EDUCATION

Michael N. Buligan

Shirley P. De Leon

Michael M. Borja

INTRODUCTION

A Practice/student-teacher is a student undergoing pre-service teaching [1][3][4][5][6][13] in a college or university completing their degree in education by teaching under the guidance of a certified teacher. They are learning the basics of teaching through hands-on experience in elementary or secondary schools, observing classroom dynamics, and delivering lessons under close supervision. Practice/Student teachers [5],[13] are expected to engage students with creative activities, assignments, and effective pacing to capture their interest. They practice communication techniques that promote student participation and learning [7] One of the greatest challenges they face is maintaining students' motivation [6][7][13], which is vital to the learning process. Student teachers are encouraged to inspire students through praise and positive reinforcement, fostering open discussions, and stimulating creative thinking. Enthusiasm, praise, and involving students in classroom activities help students feel valued and connect classroom lessons to real-life experience.

The increasing significance of technical-vocational education reflects the need for skilled labor in today's economy. Within this framework, practice teachers play a pivotal role in assessing how engaged students are in their learning processes. Their analyses can uncover key factors on the motivational approach [6][12] that influence engagement, such as teaching methods, curriculum relevance, and students' engagement [5][7]. Understanding these elements is essential for optimizing educational practices and ultimately enhancing student outcomes in technical-vocational livelihood tracks. This study aims to delve into practice-teachers' insights to identify strategies that can elevate student engagement and success in these vital programs.

However, student teachers also encounter difficulties [11][13], such as trying to apply teaching strategies they have not yet mastered. The gap between academic theory and real-world teaching can create psychological and emotional pressures, impacting their performance. They may also struggle with the uncertainty of how students will respond to them. Feelings of doubt, lack of confidence, and tension are common among new student teachers. Managing student behavior [3] is another challenge, requiring consistency, fairness, and an encouraging approach. Establishing clear classroom rules, getting to know the students, and making learning enjoyable are all strategies for fostering positive behavior.

This study aims to evaluate student teachers' motivational approach to learners' engagement in the classroom and what kind of intervention programs can be developed. The researchers, as future educators, seek to understand how to effectively assess and maintain student motivation, which will guide them as they transition into their roles as student teachers.

Framework of the Study

This study is grounded in the Self-Determination Theory by Edward L. Deci and Richard M. Ryan.(1980), which highlights the importance of intrinsic motivation—engaging in activities for personal satisfaction. Intrinsic motivation is driven by three core needs: autonomy, competence, and relatedness. When these are met, motivation, engagement, and performance improve. Extrinsic motivation, based on external rewards, can be effective short-term but may undermine intrinsic drive if overused. In classrooms, fostering autonomy, competence, and positive

relationships can enhance motivation and engagement. This theory provides a framework for understanding how student teachers assess learners' motivation and guide the development of supportive learning environments [4].

Research Aims

This study aims to evaluate student teachers' assessment of learners' motivation in the classroom as a basis for an intervention program. Specifically, it seeks to address the following questions in determining the respondents' profile regarding age, school year level, and General Weighted Average (GWA). It also seeks to understand how respondents assess learners' motivation, focusing on both extrinsic and intrinsic factors as well as their assessment of learners' classroom engagement in terms of performance tasks and discussions. Furthermore, the study will investigate whether there is a significant relationship between the profile variables and both learners' motivation and classroom engagement. Based on these findings, the study will propose an appropriate intervention program.

METHODOLOGY

This study uses a descriptive method to assess student teachers' evaluations of learners' motivation. Data was gathered through surveys, focusing on current conditions and potential causes. Purposive sampling targeted 84 BTLE graduates (17 males, 67 females) from EARIST-Cavite Campus, batch 2021-2022, ensuring relevant and reliable data from experienced participants. The survey consists of two sections: the first gathers demographic details (age, academic year, GWA), while the second assesses learners' motivation, covering extrinsic, and intrinsic motivation, performance tasks, and discussions. A five-point Likert scale, ranging from "Highly Engaged/Motivated" to "Not Engaged/Motivated," was used to measure responses, providing clear insights into the student-teachers motivational approach to learners' engagement. This approach facilitates a statistical understanding of how motivation [6][12] influences learning.

RESULTS AND DISCUSSIONS

1. Profile of the respondents in terms of their age and GWA ranged from 21 to over 51, with the majority being young adults. Of the 49 respondents, 43 were between 21-25 years old, 3 were 26-30, 1 was 31-35, and 2 were over 51. Regarding the General Weighted Average (GWA), 45% (22 students) had a GWA of 1.75, making it the most common score. This was followed by 31% (15 students) with a GWA of 1.50, 16% (8 students) with 1.25, and 8% (4 students) with 2.00. Overall, the data shows that most BTLEd students are performing well, with a GWA of 1.75 being the most frequent.

As to the respondents' assessment of the learners' motivation in terms of extrinsic and intrinsic motivation the data reveals respondents' high satisfaction with extrinsic motivation. Students are most driven by praise from teachers, parents, and peers (WM = 4.75), followed by public recognition (WM = 4.64) and financial incentives like scholarships (WM = 4.60). Secure financial assistance also plays a significant role (WM = 4.49). Rewards and recognition foster a sense of achievement (WM = 4.36), with classroom competitions also enhancing motivation (WM = 4.36) all interpreted as "**Highly Engaged**", while the Fear of negative consequences (WM = 4.09) also acts as a motivator [6][12], interpreted as "**Engaged**". Overall, extrinsic motivation is recognized as crucial for sustaining classroom engagement.

The data also shows learners are **Highly Motivated** by personal interest and passion for specific topics (WM = 4.74), enthusiasm for exploring subjects (WM = 4.66), Intellectual stimulation (WM = 4.62), a sense of accomplishment (WM = 4.55), and curiosity (WM = 4.51)

were key drivers. Students value autonomy (WM = 4.49) and freedom in choosing learning methods (WM = 4.47) and are further motivated by intellectual challenges (WM = 4.47) and overcoming obstacles (WM = 4.45). Intrinsic motivation is crucial for maintaining engagement in the classroom [13][14][15].

The respondents assessed learners' classroom engagement in terms of performance tasks and discussion shows that Performance tasks significantly boost student engagement, Real-life case studies (WM = 4.83) and classroom visuals (WM = 4.75) are highly motivating. Discussions (WM = 4.66), problem presentations (WM = 4.57), and collaborative case studies (WM = 4.55) also enhance participation. Open-ended questions (WM = 4.45), debates (WM = 4.36), and jigsaw tasks (WM = 4.34) further drive motivation all interpreted as Highly Motivated. Tasks promoting critical thinking, collaboration, and self-reflection (WM = 4.72–4.70) are valued, with group presentations (WM = 4.68) and simulations (WM = 4.60) increasing engagement. Discussions and real-world issues (WM = 4.49–4.36) foster curiosity and participation [9][11].

The significant relationship between the profile variables such as Learners' Motivation data shows that the General Weighted Average (GWA) does not significantly relate to intrinsic or extrinsic motivation, with p-values of 0.159 and 0.429, both exceeding the 0.05 significance level. Therefore, **the null hypotheses are accepted**, indicating **no significant relationship between GWA and learners' motivation**. The GWA reflects a student's average grades across all subjects, indicating overall academic performance for the year [5].

Learners' Classroom Engagement data shows **no significant relationship** between the General Weighted Average (GWA) and classroom engagement, with p-values of 0.731 and 0.145, both above the 0.05 significance level. Thus, **the null hypotheses are accepted**, indicating GWA does not affect classroom engagement. found that school engagement mediates the link between a resourceful environment and academic competence,[9] with resources impacting academic performance through behavioral and emotional engagement [11].

Based on the findings, the proposed intervention program, titled "**Empowering Motivation in Overcoming Anxiety**," aims to: (1) cultivate a genuine interest in learning beyond external pressures; (2) provide students with practical strategies to manage and overcome their fears, thereby boosting their confidence in studying; and (3) develop students' resilience and positive mindset throughout their learning journey.

CONCLUSIONS

The study leads to the following conclusions:

1. Most respondents, aged 21 to 25, were cooperative and had a 1.75 GWA.
2. Students are extrinsically motivated by praise and public recognition of achievements.
3. Student teachers' interests enhance intrinsic motivation in learners.
4. Engagement increases when students work on real-life cases related to the subject, promoting critical thinking and problem-solving.
5. An intervention program, "**Empowering Motivation in Overcoming Anxiety**," addresses the lowest intrinsic motivation scores, particularly fears of negative consequences in studies.

RECOMMENDATIONS

Based on the study's findings, the following recommendations are made:

- 1) Investigate how young adult student-teachers' academic achievements influence learner motivation and classroom environment.
- 2) Provide personalized feedback during class, focus on improving assignments, expand assessment opportunities, re-teach where necessary, and view grades as learning reflections rather than punishment.
- 3) Encourage student teachers to develop their interests, as this can enhance intrinsic motivation and classroom engagement.
- 4) Integrate real-life case topics into the curriculum to boost student engagement, critical thinking, and problem-solving skills.
- 5) Implement the "Empowering Motivation in Overcoming Anxiety" program to address intrinsic motivation related to academic fears.
- 6) Conduct interviews with student-teachers and learners to gain deeper insights into factors influencing motivation.
- 7) Have student-teachers seek feedback from peers or mentors on their assessment methods to improve performance evaluation.
- 8) Perform a follow-up study with different year levels and larger populations in various locations to further explore the same variables.

REFERENCES

- [1] Ali E, Waleed E, Fahad A., (2020). Challenges in Teaching Practice at the College of Education based on the Perceptions of Pre-Service Teachers: The Case for Kuwait University). <https://www.researchgate.net/publication/321697353>
- [2] C., S. M., & Arevalo, M. J. (2020). *Motivation in relation to teachers' performance*. <https://www.researchgate.net/publication/352130830>
- [3] Collantes, L. M. (2021). *Unveiling the problems of student teachers during practice teaching in Nueva Ecija, Region III, Philippines*. <https://onlinejournal.unja.ac.id/irje>
- [4] De Borja, J. M. A. (2020). *A literature review towards pre-service science education policy*. <https://papers.ssrn.com/sol3/papers.cfm?abstractid=3681312>
- [5] Diocos, Christine B. PhD, (2022). Learning issues encountered and motivation of teacher education students in online learning of positive school psychology. <https://www.utt Tyler.edu/elps/practitioner>
- [6] D'Shaban A., (2020). Challenges Encountered by Student Teachers in Practicing Teaching. <https://www.eajournals>.
- [7] Edward L. Deci and Richard M. Ryan, (2016.) *Self- Determination Theory: Basic Psychological Needs in Motivation, Development, and Wellness*
- [8] Ekmekci, A., & Serrano, D. M. (2022). The impact of teacher quality on student motivation, achievement, and persistence in science and mathematics. *Education Sciences*, 12(10), 649. <https://doi.org/10.3390/educsci12100649>
- [9] Feliciano H., Dianna V., (2020.) *Student's Engagement in School*. <https://files.eric.ed.gov/fulltext/EJ1222588.pdf>
- [10] Ganal, N. N., Andaya, O. J. F., & Guiab, M. R. (2018). *Problems and difficulties encountered by student teachers of Philippine Normal University campus*. <https://www.semanticscholar.org>
- [11] Gray, J. A., & D., M. (2021). *The effects of student engagement, student satisfaction, and perceived learning in online learning environments*. <https://files.eric.ed.gov/fulltext/EJ1103654.pdf>
- [12] Hamdi S., (2021). The use of Extrinsic and Intrinsic motivations to enhance student Achievement in Educational setting. <https://www.researchgate.net/publication/328429109>
- [13] Mahmood N., Iqba Z., 2018. Challenges faced by perspectives teachers during teaching Practice: Connecting Theory to Practice. <https://www.semanticscholar>.
- [14] Masatoshi Sato, Francisca Fernandez C. Juan Carlos O., 2022. Teacher motivation and burnout of English as a foreign language teacher: demotivators really demotivate them. <https://www.frontiersin.org/articles/10.3389/fpsyg>.
- [15] Toriano, J. P., Agayon, A. K. R., & Agayon, A. J. D. (2022). *Teachers in the new normal: Challenges and coping mechanisms in secondary schools*.

RESPONSIBLE CONSUMPTION AND PRODUCTION IN THE PHILIPPINES POST-COVID-19 PANDEMIC: A QUALITATIVE EXPLORATION

Emerson G. Cabudol

INTRODUCTION

The COVID-19 pandemic has engendered profound disruptions across various facets of life, compelling a reassessment of established norms and behaviors, particularly in the realms of consumption and production. This period of unprecedented upheaval has spurred an escalating interest in responsible consumption and production as individuals and businesses alike grapple with the pandemic's economic, social, and environmental ramifications. Responsible Consumption and Production (RCP), a cornerstone of sustainable development, advocates for minimizing environmental impact while promoting social well-being throughout the life cycle of goods and services (United Nations Environment Programme [UNEP], 2018).

The pandemic's disruptive force has exposed the vulnerabilities of linear economic models characterized by resource depletion and excessive waste generation. In response, a growing chorus of voices advocates for a transition towards circular economy principles, emphasizing resource efficiency, waste reduction, and closed-loop systems. This shift aligns with the core tenets of RCP, underscoring the interconnectedness of environmental sustainability, economic resilience, and social equity.

In the Philippines, a nation facing with the pandemic's multifaceted challenges, understanding the evolving landscape of consumption and production practices is paramount. The country's vulnerability to climate change, coupled with existing socioeconomic disparities, necessitates a nuanced understanding of how RCP is being shaped and embraced within this specific context. However, there is limited research exploring how the pandemic has specifically altered RCP behaviors within the Philippine context. This research gap is significant as understanding these shifts is crucial for developing effective policies and strategies to promote sustainable practices in a post-pandemic world.

Objectives

This research explored into the transformations occurring within the Philippine context, examined the shift towards responsible behaviors post-COVID-19. By employing a qualitative approach, this study aimed to unravel the intricate interplay of factors shaping RCP in the Philippines. Through in-depth interviews with consumers, producers, and experts, the research sought to:

1. Identify the key drivers and barriers to responsible consumption and production in the post-pandemic context.
2. Analyze how consumer behavior has evolved concerning sustainability, ethical sourcing, and waste reduction.
3. Examine the strategies adopted by businesses to align with responsible production principles.

This exploration hopes to shed light on the emerging trends, opportunities, and challenges inherent in the pursuit of RCP in the Philippines, contributing valuable insights to both academic discourse and policy formulation.

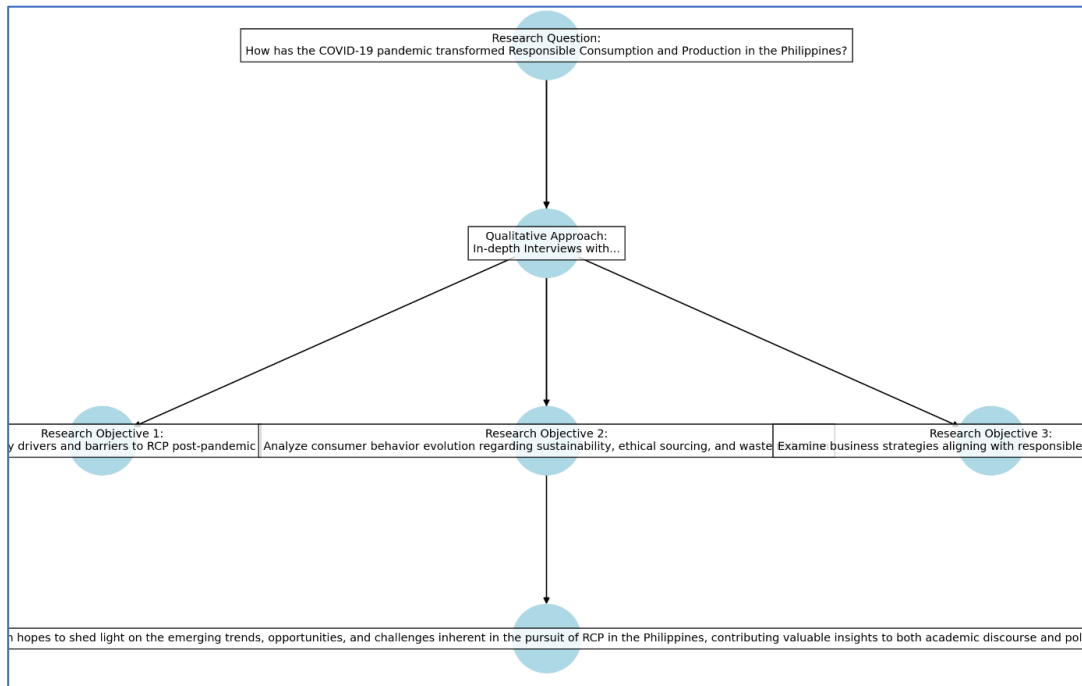

Figure 1. Research Paradigm

METHODOLOGY

This study adopted a qualitative approach to gain an in-depth understanding of the transformations in consumption and production practices in the Philippines post-COVID-19, with a specific focus on the shift towards responsible behaviors. Qualitative research is deemed most appropriate for this study as it allows for a nuanced exploration of individual experiences, perceptions, and motivations related to RCP, a multifaceted concept deeply intertwined with social and cultural contexts.

Research Design

The study employed a case study design, focusing specifically on the Philippines as a representative case of a developing country navigating the complexities of RCP in a post-pandemic world. This approach allowed for a holistic examination of the phenomenon within its real-life context, considering the interplay of various social, economic, and environmental factors.

Data Collection

Participants and Sampling

The study involved three key participant groups:

Consumers. Individuals residing in the Philippines with diverse demographic backgrounds and consumption patterns.

Producers. Representatives from businesses operating in the Philippines, ranging from small enterprises to larger corporations, with a focus on those engaged in efforts towards responsible production.

Experts. Individuals with specialized knowledge and experience in sustainable development, circular economy, consumer behavior, or related fields relevant to RCP in the Philippine context.

Purposive sampling was employed to select participants who can provide rich and diverse perspectives on the research topic. This involved identifying potential participants through relevant organizations, networks, and snowball sampling techniques.

Data Collection Methods

In-depth Interviews. Semi-structured interviews were conducted with individual participants from each group. This method allowed for flexibility in exploring emerging themes and probing deeper into participants' experiences and perspectives. Interview guides were developed for each participant group, focusing on their specific roles and experiences related to RCP.

Document Analysis. Relevant documents, such as company sustainability reports, government policies, and industry publications, were collected and analyzed to provide contextual information and triangulate findings from the interviews.

Data Analysis

Thematic analysis was employed to analyze the qualitative data collected. This involved a systematic process of:

Familiarization. Transcribing interviews and immersing oneself in the data.

Coding. Identifying and labeling meaningful patterns and themes within the data.

Generating themes. Grouping codes into broader themes that capture the essence of the data.

Reviewing themes. Ensuring the themes accurately reflect the data and refining them as needed.

Defining and naming themes. Clearly defining and naming the final themes that will be presented in the findings.

Writing up. Presenting the findings in a clear and engaging manner, supported by illustrative quotes from the data.

Ethical Considerations

Informed Consent. All participants were fully informed about the study's purpose, procedures, and potential risks and benefits before participation. Written consent was obtained from all participants.

Confidentiality and Anonymity. All data collected will be kept confidential and anonymous. Participants were assigned pseudonyms, and any identifying information were removed from transcripts and reports.

Voluntary Participation. Participants were informed that they were free to withdraw from the study at any time without penalty.

Limitations

The qualitative nature of this study means that findings cannot be generalized to the entire population of the Philippines. However, the rich, in-depth data collected provided valuable insights into the experiences and perspectives of the selected participants.

The study's focus on the post-COVID-19 context means that findings evolved as the situation continues to unfold (Tilstra, et al, 2024).

This methodology outlined a rigorous and ethical approach to exploring the complex and evolving landscape of RCP in the Philippines post-COVID-19. The qualitative approach, coupled with a robust data collection and analysis plan, generated meaningful insights into the drivers, barriers, and emerging trends shaping responsible consumption and production practices in this crucial context.

RESULTS AND DISCUSSION

This section presents the findings from the qualitative analysis of in-depth interviews and document review, exploring the transformations in consumption and production practices in the Philippines post-COVID-19, with a particular emphasis on the shift towards responsible behaviors.

Drivers and Barriers to Responsible Consumption and Production

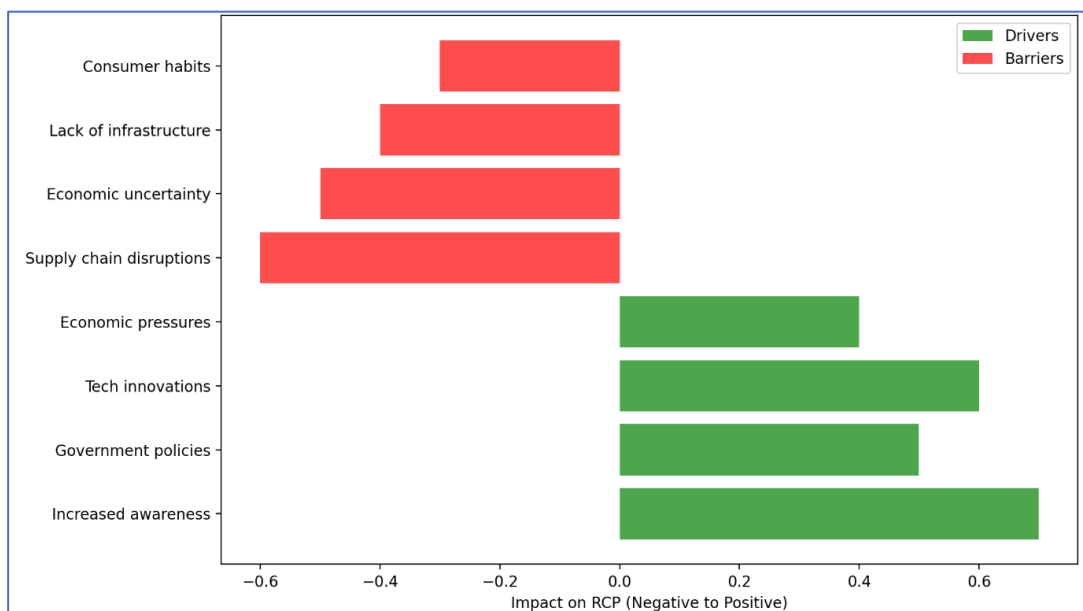

Figure 2. Key Drivers and Barriers to RCP post-pandemic

Emerging Consumer Consciousness

The interviews revealed a heightened awareness among Filipino consumers regarding the environmental and social impacts of their consumption choices. This awareness was often linked to personal experiences during the pandemic, such as supply chain disruptions and increased waste generation.

Sample Quote: "Before, I didn't think much about where my food came from. But during the lockdown, when imported goods became scarce, I realized the importance of supporting local farmers and businesses." - Consumer, Manila.

Economic Constraints

While many consumers expressed a desire to engage in more responsible consumption, economic constraints emerged as a significant barrier. The rising cost of living and limited access to affordable, sustainable alternatives posed challenges.

Sample Quote: "I want to buy eco-friendly products, but they are often more expensive. It's difficult to justify the extra cost when you're on a tight budget." - Consumer, Iloilo City.

Business Adaptations and Challenges

Businesses demonstrated varying degrees of commitment to responsible production principles. While some companies viewed sustainability as a core value and actively sought to integrate it into their operations, others faced challenges in balancing sustainability goals with economic viability.

Sample Quote: "The pandemic forced us to rethink our supply chain and explore more local sourcing options. It's not only good for the environment but also makes us more resilient to future disruptions." – Producer, Davao City.

Evolving Consumer Behavior

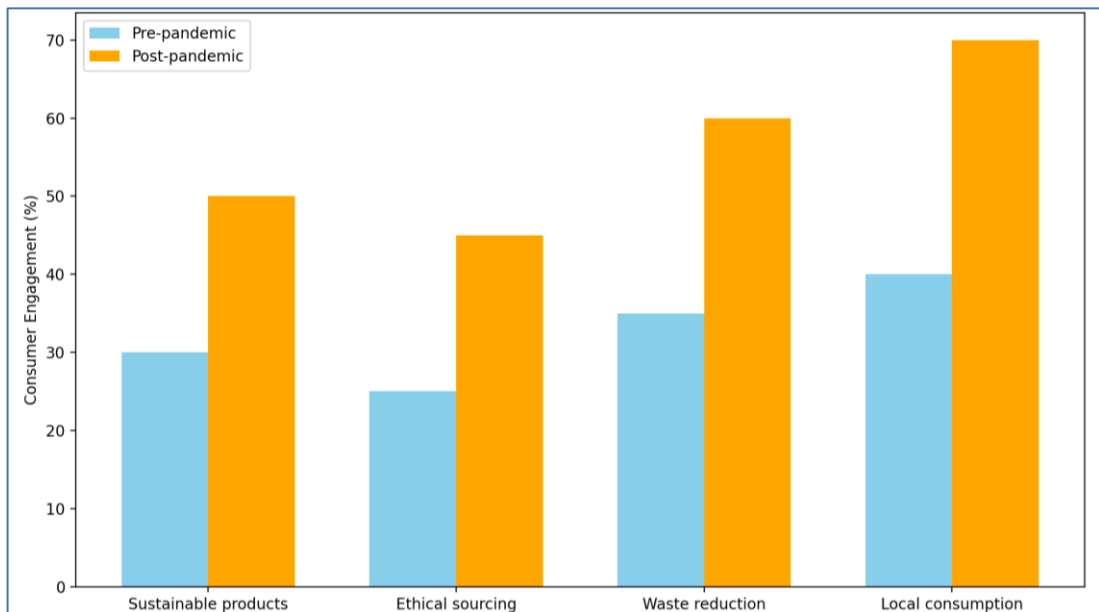

Figure 3. Consumer Behavior Evolution

Prioritizing Local and Sustainable Products

A notable shift towards supporting local businesses and seeking out sustainably produced goods was observed. This trend was driven by a desire to boost the local economy, reduce environmental impact, and promote ethical sourcing.

Sample Quote: "I'm more conscious about buying products made in the Philippines now. It's about supporting our own and knowing that the people who made them were treated fairly." - Consumer, Quezon City.

Embracing Digital Platforms and E-commerce

The pandemic accelerated the adoption of digital platforms for both consumption and production. Consumers increasingly turned to e-commerce for convenience and access to a wider range of products, while businesses leveraged online platforms to reach new markets and promote their sustainability initiatives.

Waste Reduction and Recycling Efforts

Increased awareness of waste-related issues during the pandemic prompted some consumers to adopt more conscious waste management practices, such as reducing single-use plastics and participating in community recycling programs.

Strategies for Aligning with Responsible Production

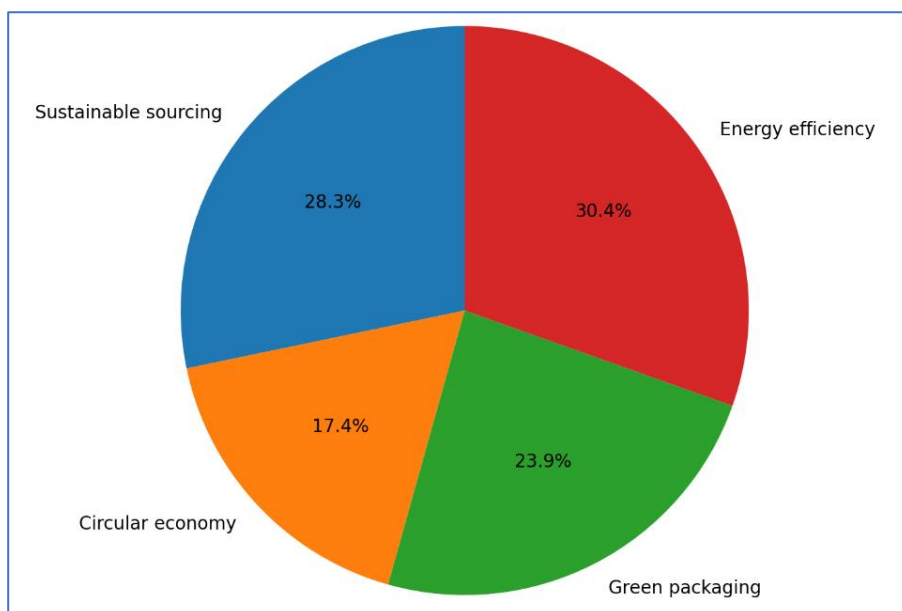

Figure 4. Business Strategies Alignment with RCP

Integrating Circular Economy Principles

Businesses demonstrated a growing interest in adopting circular economy models, such as reducing waste through upcycling and recycling, implementing closed-loop systems, and extending product lifecycles.

Enhancing Supply Chain Transparency

Companies recognized the importance of transparency in building trust with consumers. Some businesses implemented traceability systems to provide information about the origin and ethical sourcing of their products.

Collaborating for Impact

Partnerships between businesses, government agencies, and non-profit organizations emerged as crucial for driving systemic change towards more responsible consumption and production practices.

IMPLICATIONS AND FUTURE DIRECTIONS***Policy Interventions and Support***

The findings highlight the need for supportive policies and regulations to incentivize businesses to adopt sustainable practices and make responsible choices more accessible to consumers.

Consumer Education and Empowerment

Continued efforts to educate consumers about responsible consumption and empower them to make informed choices are essential.

Further Research

This study provides a valuable snapshot of the evolving landscape of RCP in the Philippines post-COVID-19. Further research is needed to track long-term trends, explore the effectiveness of interventions, and delve deeper into specific aspects of consumer and producer behavior.

REFERENCES

- Babia, E A D J P. (2021, April 14). EDUCATION SUSTAINABLE DEVELOPMENT-COMMUNITY BASED PROJECTS OF THE PHILIPPINES. , 58(3), 3998-4007. <https://doi.org/10.17762/pae.v58i3.4605>
- Biondi, C N A. (2023, February 7). Covid-19 has emphasized the importance of brand transparency. <https://www.voguebusiness.com/sustainability/fashion-revolution-transparency-index-2020-covid-19>
- By, T A W P. (2023, February 27). Managing COVID-19: How the pandemic disrupts global value chains. <https://www.weforum.org/agenda/2020/04/covid-19-pandemic-disrupts-global-value-chains/>
- Calvo-Porrá, C., & Lévy-Mangín, J. (2020, May 2). The Circular Economy Business Model: Examining Consumers' Acceptance of Recycled Goods. Multidisciplinary Digital Publishing Institute, 10(2), 28-28. <https://doi.org/10.3390/admsci10020028>
- Correia, E. M. d. F. (2023). Supply Chain Sustainability: Towards a Maturity Model (Order No. 30724668). Available from ProQuest Dissertations & Theses A&I. (2913079982). <https://www.proquest.com/dissertations-theses/supply-chain-sustainability-towards-maturity/docview/2913079982/se-2>

- COVID-19 and global value chains: Policy options to build more resilient production networks. (2023, February 7). <https://www.oecd.org/coronavirus/policy-responses/covid-19-and-global-value-chains-policy-options-to-build-more-resilient-production-networks-04934ef4/>
- Das, D I A. (2023, February 23). Coronavirus (COVID-19/SARS-CoV-2) and supply chain resilience: a research note. <https://www.inderscienceonline.com/doi/abs/10.1504/IJISM.2020.107780>
- Devenyns, J. (2023, February 23). Consumers still care about sustainability amid pandemic, report finds. <https://www.fooddive.com/news/consumers-still-care-about-sustainability-amid-pandemic-report-finds/576682/>
- Fhumspv@ku.ac.th, N V K U 1 B T. (2023, November 10). Investigation and recommendations on the promotion of sustainable consumption behavior among young consumers in Thailand. <https://www.sciencedirect.com/science/article/pii/S2452315118300444>
- Girard, M B T A S A B P. (2023, April 14). Tips for extending material responsibility in supply chains | Greenbiz. <https://www.greenbiz.com/article/tips-extending-material-responsibility-supply-chains>
- Greening Manufacturing - Securing The Future of Philippine Industries. (2023, February 7). <https://industry.gov.ph/greening-manufacturing/>
- Gue, I H V., Promentilla, M A B., Tan, R R., & Ubando, A T. (2020, December 1). Sector perception of circular economy driver interrelationships. Elsevier BV, 276, 123204-123204. <https://doi.org/10.1016/j.jclepro.2020.123204>
- Güngör, D Ö., Sharma, M., Dhir, A., & Daim, T. (2022, February 1). Supply chain resilience during the COVID-19 pandemic. Elsevier BV, 68, 101847-101847. <https://doi.org/10.1016/j.techsoc.2021.101847>
- Hub, I S K. (2023, February 7). Goal 12 - Responsible Consumption & Production | SDGs | SDG Knowledge Hub | IISD. <https://sdg.iisd.org/sdgs/goal-12-responsible-consumption-production/>
- ISO 59020:2024. (2024, May 22). https://www.iso.org/standard/80650.html?utm_source=twitter&utm_medium=organic_social&utm_campaign=circular-stds-launch
- Ivanov, D., & Mouchère, H. (2021, May 29). Stress testing supply chains and creating viable ecosystems. Springer Science+Business Media, 15(1-2), 475-486. <https://doi.org/10.1007/s12063-021-00194-z>
- Kim, N., & Lee, K. (2023, March 29). Environmental Consciousness, Purchase Intention, and Actual Purchase Behavior of Eco-Friendly Products: The Moderating Impact of Situational Context. Multidisciplinary Digital Publishing Institute, 20(7), 5312-5312. <https://doi.org/10.3390/ijerph20075312>
- Kingdom, A P M V U O L L 9 L U K A P P U O L L 9 L U. (2023, November 10). Principles for a sustainable circular economy. <https://www.sciencedirect.com/science/article/pii/S2352550921000567>
- Latest research shows that sustainability is surviving COVID-19. (2023, February 7). <https://non-gmoreport.com/latest-research-shows-that-sustainability-is-surviving-covid-19/>

- Li, X., Wang, H., Lu, Y., & Li, W. (2021, July 30). A Critical Survey on Renewable Energy Applications in the Philippines and China: Present Challenges and Perspectives. *Frontiers Media*, 9. <https://doi.org/10.3389/fenrg.2021.724892>
- Lim, K., Lim, S., & Yoo, S. (2014, February 21). Oil Consumption, CO2 Emission, and Economic Growth: Evidence from the Philippines. *Multidisciplinary Digital Publishing Institute*, 6(2), 967-979. <https://doi.org/10.3390/su6020967>
- Monsod, T M C., Ahmed, S., & Hilario, G P. (2021, August 30). (DP 2021-05) Accelerating Resilience and Climate Change Adaptation: Strengthening the Philippines' Contribution to Limit Global Warming and Cope with its Impacts. Federal Reserve Bank of St. Louis. <https://econ.upd.edu.ph/dp/index.php/dp/article/view/1541>
- Mureşan, I., Harun, R., Brata, A M., Brata, V D., Chiciudean, D., Tirpe, O P., Poruţiu, A., & Dumitraş, D E. (2022, July 29). Factors Affecting Food Consumers' Behavior during COVID-19 in Romania. *Multidisciplinary Digital Publishing Institute*, 11(15), 2275-2275. <https://doi.org/10.3390/foods11152275>
- Myers, N. (1988, January 1). Environmental Degradation and Some Economic Consequences in the Philippines. *Cambridge University Press*, 15(3), 205-214. <https://doi.org/10.1017/s0376892900029337>
- News, A. (2023, February 23). PH shoppers among world's most socially conscious - study. <https://news.abs-cbn.com/business/06/17/14/ph-shoppers-among-worlds-most-socially-conscious-study>
- Philippines, A S F C D L S U M P A L D L U L T N Y G S J T U 2 S C C R U O T P L B P E T D L S U M. (2023, November 10). Philippine resource efficiency in Asian context: Status, trends and driving forces of Philippine material flows from 1980 to 2008. <https://www.sciencedirect.com/science/article/pii/S095965261730611X>
- Plastic Ban and Regulation. (2023, February 27). <https://climate.gov.ph/our-programs/anti-single-use-plastic-campaign/plastic-ban-and-regulation>
- Raman, R., Lathabai, H. H., & Nedungadi, P. (2024). Sustainable development goal 12 and its synergies with other SDGs: identification of key research contributions and policy insights. *Discover Sustainability*, 5(1), 150. <https://doi.org/10.1007/s43621-024-00289-0>
- REPUBLIC OF THE PHILIPPINES SUSTAINABLE FRAMEWORK - Department of Finance. (2023, February 27). <https://www.dof.gov.ph/issuances/sustainable-finance-framework/>
- Rincón, A G., Barbosa, R L C., Álamo, E M., & Cánovas, B R. (2021, January 15). Sustainable Consumption Behaviour in Colombia: An Exploratory Analysis. *Multidisciplinary Digital Publishing Institute*, 13(2), 802-802. <https://doi.org/10.3390/su13020802>
- Risk, resilience, and rebalancing in global value chains. (2023, February 6). <https://www.mckinsey.com/capabilities/operations/our-insights/risk-resilience-and-rebalancing-in-global-value-chains>
- Sabado, J R F., Albutra, J M B., Centino, S M P., & Yap, W B C. (2022, September 10). DETERMINANTS OF ENERGY CONSUMPTION: A REVIEW OF THE PHILIPPINE ENERGY SECTOR. , 6(3). <https://doi.org/10.46827/ejefr.v6i3.1323>

- Saculsan, P G. (2018, June 1). Analysis of the Constraints in the Renewable Energy Sector within a Multi-level Energy Transition Perspective (MLP): The Case of the Philippines. IOP Publishing, 159, 012025-012025. <https://doi.org/10.1088/1755-1315/159/1/012025>
- Santos, K E S. (2017, January 1). Purchasing habits of students toward Green Marketing in Nueva Ecija, Philippines. Infogain Publication, 2(5), 2770-2774. <https://doi.org/10.22161/ijeab/2.5.63>
- Setijaningrum, A K A K. (2023, October 27). Behavioral Intention and The Influence of Demographic Factors in Purchasing Environmentally Sustainable Products among Residents in Petaling. https://hrmars.com/papers_submitted/18024/behavioral-intention-and-the-influence-of-demographic-factors-in-purchasing-environmentally-sustainable-products-among-residents-in-petaling.pdf
- Shifting sands: How consumer behaviour is embracing sustainability. (2023, February 6). <https://www2.deloitte.com/ch/en/pages/consumer-business/articles/shifting-sands-sustainable-consumer.html>
- Sustainability & Consumer Behaviour 2022. (2023, April 13). <https://www2.deloitte.com/uk/en/pages/consumer-business/articles/sustainable-consumer.html>
- Sustainable consumption and production ∴ Sustainable Development Knowledge Platform. (2023, February 6)
- Sustainable Development Goal 12: Responsible Consumption and Production. (2023, February 27). <https://vietnam.un.org/en/sdgs/12>
- Tilstra, A. M., Polizzi, A., Wagner, S., & Akimova, E. T. (2024). Projecting the long-term effects of the COVID-19 pandemic on U.S. population structure. *Nature Communications*, 15(1), 2409. <https://doi.org/10.1038/s41467-024-46582-4>
- What Supply Chain Transparency Really Means. (2023, February 6). <https://hbr.org/2019/08/what-supply-chain-transparency-really-means>
- Xu, Z., Elomri, A., Kerbache, L., & Omri, A E. (2020, September 1). Impacts of COVID-19 on Global Supply Chains: Facts and Perspectives. *Institute of Electrical and Electronics Engineers*, 48(3), 153-166. <https://doi.org/10.1109/emr.2020.3018420>

SOCIAL SUPPORT AND WELL-BEING OF PERSONS WITH DISABILITIES (PWD) OF GENERAL MARIANO ALVAREZ CAVITE: BASIS FOR INTERVENTION PROGRAM

*Nancy G. Liwanag
Mark Joseph A. Viado*

INTRODUCTION

Social support encompasses feeling loved and valued. Many studies highlight its protective role in mental health. Yet it impacts mental well-being. Fostering the well-being of all students is a top priority in today's varied and inclusive educational environment. People with disabilities (PWD) are ranked as a prominent and frequently ignored segment among the student groups needing particular attention. The quest for happiness is a common human activity that cuts across age, gender, and physical limitations. However, this goal can be challenging and diverse journey for PWD students, where the availability of strong social support can make a significant impact. In addition to the absence of illness, the idea of well-being also includes the presence of favourable psychological traits and experiences that enhance a person's general quality of life. This idea assumes special significance for PWD students as they negotiate not just the standard academic difficulties but also challenges brought on by their disability. The essential tenet of well-being known as social is crucial to the lives of students with disabilities. It includes the support services offered by educational institutions and by friend, family, teachers, classmates, and other who provide emotional, informational, and practical help. This assistance is not just a nicety; it is an essential tool that can have a big impact on a PWD students' academic success, self-worth, mental health, and general sense of well-being. Low support relates to higher depression, anxiety, and self-harm. (Bedaso et al., 2021). Those with weaker support face difficulties in depression recovery and social functioning (Wang et al., 2018). Anxiety among informal carer sows a negative link with perceived support (Priego-Cubero et al., 2023). Although the value of social support in fostering PWD students' well-being is widely accepted, there is a significant knowledge gap about the precise kinds, origins, and efficacy of these support systems in educational environments. There is still much to learn about the subtleties of how different types of social support affect the well-being of PWD students, as well as how well the current support systems meet their particular requirements. In effort to address the knowledge gap, this study investigated the social support and well-being of PWD students. This study sought to contribute not only to the academic discourse on social support and well-being but also to the practical realm.

MATERIALS AND METHODS

The descriptive method was used to examine social support and the well-being of PWD students in GMA Cavite. Fluet (2021) defines the descriptive survey approach as the systematic collection of data to characterize a certain phenomenon, circumstance, or population. It is a reliable quantitative research technique used to assess certain hypotheses and characterize characteristics or functions. Additionally, Chaudhari (2021) cited that a descriptive survey design includes questions important to the research topic. The survey questions are then made available to the respondents in an effort to get honest responses. Further, the study used the convenience sampling technique to collect information from participants. This method allows researchers to make decisions based on their understanding of the research context and scientific structure of PWD students. Hirschauer et al. (2020) states that convenience samples allow researchers to avoid non-coverage and obtain a sampling frame with a randomly selected subject pool. However, self-selection is frequently unachievable because individuals choose whether or not to complete the questionnaires or take part in the examination. According to Alvi (2016), the

populations that are targeted categories are sufficiently broad to allow for the creation of an infinite number of subcategories within them that are essentially distinct from one another and are hence insufficiently representative of one another. Additionally, it is possible to measure or adjust the sample’s participant variability. In order to collate data, the self-made survey questionnaire was utilized and validated by a professional psychometrician. The draft questionnaire was toned to match the respondents’ knowledge readiness. This study analysed and interpreted the results using the Pearson r correlation and Chi-square.

RESULTS AND DISCUSSION

Table 1 presents the relationship between the profile variables in terms of gender, socio-economic status, and type of disabilities, and the level of social support.

Table 1
Relationship between Profile Variables and Level of Social Support

Profile Variables	p-value	Interpretation	Hypothesis
Gender vs Emotional Support	.032	Reject Ho	Significant
Gender vs Companionship Support	.035	Reject Ho	Significant
Socio-economic status vs Tangible Support	.001	Reject Ho	Significant
Socio-economic status vs Companionship Support	.002	Reject Ho	Significant
Type of Disabilities vs Emotional Support	.000	Reject Ho	Significant

Note: Level of significance at .05

Data reveals that there is association between the profile variable as to gender and level of social support as to emotional support and companionship support supported by computed p-value of .032 and .035 respectively. Meanwhile, the socio-economic status and level of social support in terms of tangible and companionship support also associated based on the computed p-values of .001 and .002. Moreover, the type of disabilities of the participants was also found associated to the level of social support in terms of emotional support based on the computed p-value of .000. Thus, the null hypotheses are rejected. This implies that differences in gender have different means of emotional, companionship and tangible support. This study proves that gender has relationship with level of social support as to informational support, and tangible support. It means that the intersection of gender and disability difficulties for women impeding their rights and societal inclusion more than men.

Further, there is association between socio-economic status and the respondent’s level of social support as to tangible support and companionship supported by computed p-values of .001 and .002 respectively. Hence, the null hypotheses are rejected. This means that the level of social support as to tangible and companionship support were affected by the respondents’ socio-economic status. This proves that socio-economic status has relationship with level of social support. It means that people with disabilities have a labor force participation markedly less than the rate for those without disabilities, affecting the overall socio-economic status of families.

Moreover, the type of disabilities and emotional support was found associated based on the computed p-value of .000. It means that students experiencing chronic health issues, who indicated that their activities and social interactions were affected, demonstrated notably elevated levels of depressive symptoms compared to their counterparts without such conditions.

Table 2
Relationship between Profile Variables and Level of Well-being

Profile Variables	p-value	Interpretation	Hypothesis
Age vs Self-Acceptance	.006	Reject Ho	Significant
Age vs Personal Growth	.034	Reject Ho	Significant
Age vs Autonomy	.003	Reject Ho	Significant
Gender vs Positive Relations	.002	Reject Ho	Significant
Gender vs Personal Growth	.004	Reject Ho	Significant
Socio-economic status vs Self-Acceptance	.000	Reject Ho	Significant
Socio-economic status vs Personal growth	.011	Reject Ho	Significant
Socio-economic status vs Autonomy	.001	Reject Ho	Significant
Socio-economic status vs Positive Relations	.006	Reject Ho	Significant
Type of disabilities vs Self-Acceptance	.009	Reject Ho	Significant
Type of disabilities vs Personal Growth	.001	Reject Ho	Significant

Note: Level of significance at .05

As shown in Table 2 is the relationship between age and level of well-being as to self-acceptance, personal growth and autonomy. Results reveals that the profile variable-age is significantly associated to self-acceptance, personal growth and autonomy supported by computed p-values of .006, .034 and .003 respectively. This implies that age has relationship with the participants well-being. Canha et al. (2010) stated that adolescents with disabilities often reported that they felt unhappy, and had a poorer perception of their health.

Further, the socio-economic status has also relationship with the well-being of the participants as to self-acceptance, personal growth, positive relations and autonomy supported by computed p-values of .000, .011, .001 and .006 respectively. This means that the well-being of the participants was affected by their level of socio-economic status. According to Reyes et al. (2014) stating the common reasons for the students with disabilities not to continue their education is due to poverty.

Meanwhile, the type of disabilities is also found associated to well-being as to self-acceptance and personal growth supported by computed p-values of .009 and .001. According to Emerson et al. (2020) there is evolving body of knowledge suggesting that disability-related inequalities in well-being do not reflect a direct negative impact of impairment, but rather that demographic characteristics and exposure to social determinants of poor health play a major role in the negative association between disability and well-being.

Table 3
Relationship between Social-Support and Level of Well-being

Variables	p-value	Interpretation	Hypothesis
Socio-economic status vs Self- Acceptance	.000	Reject Ho	Significant
Socio-economic status vs Positive Relations	.011	Reject Ho	Significant
Socio-economic status vs Personal Growth	.001	Reject Ho	Significant
Socio-economic status vs Purpose in life	.148	Fail to Reject Ho	Not Significant
Socio-economic status vs Environmental Mastery	.249	Fail to Reject Ho	Not Significant
Socio-economic status vs Autonomy	.006	Reject Ho	Significant

Table 3 shows that there is association between socio-economic status and well-being of the respondents as to self-acceptance, positive relations, personal growth and autonomy supported by computed p-value of .000, .011, .001, and .006 which are less than the .05 level of significance. Hence, the null hypotheses are rejected. Meanwhile, there is no association between socio-economic status and well-being of the respondents as to purpose in life and environmental mastery supported by computed p-values of .148 and .249 are all greater than .05 level of significance, hence, the null hypotheses are accepted. This means that there is no significant relationship between the PWD students' socio-economic status and well-being as to purpose of life, environmental mastery.

According to the survey conducted by Reyes et al. (2014), the common reasons for persons with disabilities, not finishing their education are due to poverty. Also, three (3) out of 10 respondents are aware of the policies intended to improve their well-being.

This study proves that socio-economic status has no relationship with level of well-being as to self-acceptance, positive relations, personal growth, and autonomy. However, there is association between socio-economic and well-being of the respondents as to self-acceptance, positive relations, personal growth and autonomy. It means that lack of financial resources hinders the education completion of individuals with disabilities, and only 30% of respondents are familiar with policies aimed at enhancing their well-being.

CONCLUSION

The results of evaluation on social support in relation to emotional, informative, tangible, and companionship aspects show a favourable impression, with ratings showing agreement in feeling supported in these areas. The findings on well-being indicate that students generally have a slightly lower level of agreement with regards to self-acceptance and purpose in life, though still within the "agree" range. They expressed agreement with the following aspects of well-being namely autonomy, growth as an individual, positive relationships with others, and environmental mastery. The study found that different demographic profiles have different level of connection with respondents' social support and well-being. Most characteristics of social support and well-being have no significant connection with age, educational attainment, and kind of disability. However, sex and socio-economic level have significant connections with various types of social

support and well-being. These findings illustrate the complex relationship between demographic characteristics and people's sense of social support and well-being. Further, the findings show an association between social support and respondents' well-being leading to the rejection of the null hypothesis and confirming the idea that social support is related to participant well-being. Centering on the domain of well-being, self-acceptance, purpose in life, and social support, the intervention initiative will discuss the following: In self-acceptance domain, the goal is to aid students with disabilities by employing reflective counselling to nurture self-acceptance, increase awareness of hidden disabilities, and devise personalized approaches for confidently embracing their identities. Activities include self-reflection exercises, open discussions on concealing disabilities, and encouraging contemplation of personal strengths, with success gauged by noticeable improvements in students' self-esteem during these exercises. In the purpose in life domain, program seeks to formulate strategies for individuals with disabilities to overcome obstacles and pursue aspirations. Activities encompass goal setting, action planning, discussions on common challenges, brainstorming strategies, breaking down long-term goals, and creating tailored action plans. Success is measured by enhanced resilience and adaptability, facilitating the successful pursuit of aspirations despite disabilities; and in the social support and well-being realm, the program emphasizes fostering the exchange of personal stories to evoke empathy, empowerment, and the establishment of robust support networks for students with disabilities. Story-sharing exercises involve narrative sharing circles, discussions, the provision of empowering information, activities to deepen participants' understanding, and encouragement to reflect on shared experiences. Success indicators include heightened empathy, improved mutual understanding, and reinforced social connections leading to a strengthened support system and enhanced well-being for students with disabilities.

REFERENCES

- Bedaso, A., Adams, J., Peng, W., and Sibbritt, D. (2021). The relationship between social support and mental health problems during pregnancy: a systematic review and meta-analysis. *Reprod Health* 18, 1-23.
- Chaudhari, A. (2021). Research design. <https://www.scirp.org>
- Hirschauer, N., Gruner, S., Musshoff, O. & Becker, C. (2020). Can p-values be meaningfully interpreted without random sampling? *Statistics Surveys* 14, 71-91.
- Priego-Cubero, E., Ortega, V., Lopez-Martinez, C., and del Pino Casado, R. (2023). The relationship between social support and anxiety symptoms in informal carers: a systematic review and meta-analysis. *J. clinic Med* 12:1244
- Reyes, M. L. & Yujico, I. C. (2014). Psychological distress among college youth as a function of family SES: The mediating effect of senses of poverty and the mitigating role of family resources. *Journal of Pacific Rim Psychology* 8, 95-104.
- Ryff, C.D. & Reyes, C. (1995). The "Six-Factor Model of Psychological Well-being". Retrieved from: https://www.researchgate.net/publication/234709528_The_Scales_of_Psychological_WellBeing_A_Study_of_Validity_and_ReliabilitySciences. 9(1), 21-28.
- Wang, D., Zhu, F., Xi, S., Niu, L., Tebes, J.K., Xiao, S., et al (2021). Psychometric properties of the Multidimensional Scale of Perceived Social Support (MSPSS) among family caregivers of people with schizophrenia in China. *Psychology Research Behavior Management* 14, 1201-1209. doi:10.2147/PRBM.S320126

POSTMILLENNIAL LEVEL OF COMMITMENT: A CASE OF WORKING STUDENTS IN BPO INDUSTRY

Hernan M. Oliveros

INTRODUCTION

Post-millennials or Generation Z refer to individuals born from the mid-1990s to the early 2010s. They are often considered the first generation to grow up with widespread access to technology from a young age. They are highly comfortable with digital devices, social media, and online communication. Majority of them are reported to have a strong entrepreneurial spirit. They often seek alternative paths to success and are interested in creating their own opportunities, whether through starting their own businesses or engaging in freelance work. Post-millennials are often characterized as socially conscious and concerned about global issues. They are more likely to engage in activism and express their opinions on social and political matters. This generation tends to embrace diversity and inclusion. They are more likely to appreciate and advocate for equality and representation across various aspects of life, including race, gender, and sexual orientation. Post-millennials are known for valuing individuality and authenticity. They often seek to express their unique identities and are less inclined to conform to traditional societal expectations. There is a trend toward valuing practical skills and experiences. Post-millennials are often interested in gaining relevant skills through various means, including online courses and self-directed learning. Due to the internet and social media, post-millennials have a strong sense of global connectivity. They are more likely to have friends and influences from around the world, which can shape their perspectives.

Business Process Outsourcing (BPO) is a business operation to a third-party seller or service provider who caters customer technical or inquiry concerns for other businesses. The call center agents play a part in achieving satisfaction among users, that's why they handle client concerns from different companies. The Philippines is a prioritized destination by the investor to put up this industry. This is due to excellent communication skills of Filipinos in the English language, young labor force, and also due to low salary.

Business Processing Outsourcing (BPO) provides outsourcing services to a particular business that performs specific tasks and operations according to the client's wants. It is one of the fastest growing and strong sectors in the Philippines, producing well-paying jobs for the Filipino people. The Philippines is one of the world's top destinations for outsourcing services, as it's estimated that 1.3 million Filipinos have been employed in over 1,000 BPO companies in the country in the year 2019, showing that it contributes 8-10% growth every year. With a high literacy rate, and a hospitable and polite culture, the Philippines is suited to the demands and understanding of being one of the most popular outsourcing countries.

In this industry, the root source of quality and productivity gain is the employee itself. It's veritably important for the company to see workers as the fundamental source of enhancement, growth, and job satisfaction wherein it not just motivates the employee but also increases their performance as a whole. Job satisfaction pertains to the overall attitudes and feelings of employees in relation to work (Kaur et al., 2020). Job Satisfaction is the continuance of the organizational commitment because it is considered as one of the most important components of work motivation (Lai-Bennejean & Beitelspacher, 2020). A satisfied employee may have a high level of commitment, which benefits both the company and employee. There are several determinants of job satisfaction; salaries and benefits, promotion, rewards and working environments (workplace, clients, colleagues and superior) are some of them.

In today's modern age, commitment is more looked at in new-generation employees. As strong and vibrant characters associated with postmillennialism, during the pandemic, most of them explore the BPO industry while taking up online classes. This move is attributed to attractive compensation and the workplace in BPO (Thompson, 2020). As new to the industry, most of them are experiencing hardship due to the differences in cultural, ethnicity, and time zones of customers. One of the common problems that a call center agent encounters is rude and arrogant customers. No matter how untoward behavior they treat the agent, they always insist that the customer is always right. So, a specific set of hard and soft skills for effective communication with customers is essential for the agent to convince and receive positive feedback from the customer.

Dysfunctions in role performances have an impact on employee's well-being and an organization's ability to function. Conflicts can also be one that decrease worker's performance and have been suggested as determining factors of employee's job satisfaction and organizational commitment. The time constraints require the agent to work based on the customer timeframe. This altered the usual body clock, leading to change the usual daily routine of the agent. Adding the mental stress, they regularly receive from their customer, this affects mental and physical health which results in influencing their productivity and commitment. Navas, 2022 stated that, working students in a BPO industry prioritized job or school over health.

This study investigated the level of work commitment of students of Eulogio Amang Rodriguez Institute of Science and Technology (EARIST) working in BPO Industry. This study also aimed to determine problems encountered by the students from their workplace and academics.

METHODS

This study utilized a descriptive research design to investigate and establish the correlation between the level of work commitment among working students serving as respondents and the challenges they face. Employing a quantitative approach, the collected data underwent systematic analysis to facilitate a straightforward interpretation of the results.

The choice of a descriptive research methodology was instrumental in offering a comprehensive outlook of the perceived work commitment levels of the participating working students. This approach allowed for the identification and documentation of specific problems encountered by these individuals, contributing to a nuanced understanding of the relationship between work commitment and challenges faced during their academic pursuits.

The quantitative approach employed in the data analysis phase involved the use of statistical tools to quantify and interpret the collected information. This method not only facilitated a systematic examination of the data but also enabled the derivation of numerical insights, enhancing the precision and clarity of the findings. By utilizing quantitative measures, the study aimed to provide a solid foundation for drawing reliable conclusions regarding the observed relationship between work commitment and encountered challenges among working students.

In essence, the adoption of a descriptive research design, coupled with a quantitative approach to data analysis, allowed for a methodical exploration of the dynamics between work commitment and challenges faced by working students. This comprehensive investigation provides valuable insights that can inform strategies and interventions to support the academic success and well-being of this specific demographic.

Population

The respondents of the study are fifty (50) working students from the College of Business and Public Administration. These respondents are chosen using purposive-convenience sampling, a non-probability sampling technique where respondents were selected based on the characteristics of a population (Palys, 2008). These respondents are from different years and their ages range from 20 yrs./o up to 24 yrs./o. The majority are in their first and second year of college (10 and 20 respondents, respectively).

Research Instrument

The study utilized a research-made questionnaire in which consisted of demographic profile and survey to measure the level of work commitment. This instrument undergoes a series of validations. The first stage was validated by selected team leaders and supervisors of BPO’s. After the incorporation of their feedback, experts from academe commented on the instrument. This was made to ensure accuracy and readability of the questions, so respondents will find it easy to understand.

The criteria identified by the researcher on level of work commitment are company policy, working condition, salary and benefits and career developments. There are 5 established indicators created by the researchers in this study. To interpret the result, a Five (5) - Point Likert Scale Method was used as the basis for interpretation.

Range	Scale	Verbal Interpretation	Symbol
5	4.20-5.00	Far Above Standard	FAS
4	3.40-4.19	Above Standard	AS
3	2.60-3.39	Meets Standard	MS
2	1.80-2.59	Below Standard	BS
1	1.00-1.79	Far Below Standard	FBS

RESULTS

Measuring the commitment of workers to company policies involves assessing their adherence, engagement, and alignment with the established rules and guidelines. Based on Table 1, the assessment on the level of commitment of the postmillennial as to company policy as far above standard with an overall mean of 4.38. All items rated Far Above Standard (FAS). In this criterion, “measure your engagement levels and commitment to company policies” obtained the top spot followed by “assess how well you connect your actions to company’s core values”. The last spot, which got 0.19 score from the top spot (4.54) is “Involvement in open discussions within teams about the importance of policy adherence and its impact on the work environment”.

Table 1
Level of Commitment of Postmillennial as to Company Policy

Indicators	WM	VI	Rank
1. Ensure to have formal acknowledged and understanding of key policies.	4.40	FAS	3
2. Commit to the principles of democracy and social justice through fair, transparent, inclusive, and sustainable policies and practices.	4.38	FAS	4
3. Assess how well to connect actions to the company's core values.	4.46	FAS	2
4. Involvement in open discussions within teams about the importance of policy adherence and its impact on the work environment.	4.35	FAS	5
5. Measure engagement levels and commitment to company policies.	4.54	FAS	1
Overall Weighted Mean	4.43	FAS	

Measuring a commitment to their working conditions involves evaluating various factors related to their satisfaction, well-being, and engagement in the workplace. The responses of postmillennial on the level of working commitment as to working condition is illustrated in Table 2. Similar to Table 1, all of the indicators of working conditions obtained a Far above Standard (FAS) with a grand weighted mean of 4.49. Garnered a top score with weight mean of 4.58 is "evaluate the balance between work hours and personal time". Second to this is "evaluate how transparent the organization is about decisions affecting work conditions with a weighted mean of 4.54. Rank third on the assessment of postmillennial is "encourage team-building activities to foster positive relationships among colleagues. This is followed by "measure employee participation in workplace activities and initiatives" and on the last rank is "offer training and development programs to enhance skills and knowledge.

This result may be associated with the work status of postmillennials. In this study, they are contractual, temporary or probationary employees since they are working while studying at the same time. They consider most probably their first job experience which will soon leave the company after they graduate in college. It is worth mentioning that these respondents top their score on work-life balance, which reflects being in this generation.

Table 2
Level of Commitment of Postmillennial as to Working Conditions

Indicators	WM	VI	Rank
1. Evaluate the balance between work hours and personal time.	4.58	FAS	1
2. Measure employee participation in workplace activities and initiatives.	4.44	FAS	4
3. Evaluate how transparent the organization is about decisions affecting working conditions.	4.54	FAS	2
4. Offer training and development programs to enhance skills and knowledge.	4.38	FAS	5
5. Encourage team-building activities to foster positive relationships among colleagues.	4.50	FAS	3
Overall Weighted Mean	4.49	FAS	

Measuring a worker's commitment to their salary and benefits involves evaluating their satisfaction, perceived value, and engagement related to their compensation package. Table 3 demonstrated the evaluation of postmillennials on their level of commitment based on salary and benefits. This result is similar to the previous discussion (see Tables 1 & 2). A grand mean of 4.44 which is rated as FAS, these working students are highly motivated and committed to the company because of their well-compensated hard work. The recognize and reward exceptional performance through various programs evaluated the highest with weighted mean of 4.50. This

followed by the conduct of regular surveys to gauge employee satisfaction with their compensation, a difference of 0.02. The next indicator based on the same table is the establishment of clear communication channels for discussing compensation-related concerns. The support overall employee satisfaction well-being, including financial wellness and acknowledge and reward employees for their long-term commitment to the organization bagged the 4th and the 5th rank, respectively. The mean values of the indicators under salary and benefits are ranging from 4.34-4;50. Kirchmayer & Fraticova (2020) said that postmillennials prefer working with flexible time, space and personal independence. They do not want to be committed for a long time otherwise they are motivated and feel contentment.

Table 3
Level of Commitment of Postmillennial as to Salary and Benefits

Indicators	WM	VI	Rank
1. Conduct regular surveys to gauge employee satisfaction with their compensation.	4.48	FAS	2
2. Acknowledge and reward employees for their long-term commitment to the organization.	4.34	FAS	5
3. Recognize and reward exceptional performance through various programs.	4.50	FAS	1
4. Support overall employee well-being, including financial wellness.	4.44	FAS	4
5. Establish clear communication channels for discussing compensation-related concerns.	4.46	FAS	3
Overall Weighted Mean	4.44	FAS	

The level of commitment to career development is crucial for both employees and organizations as it influences individual growth, job satisfaction, and overall organizational success. Table 4 demonstrated the level of commitment of postmillennials as to career development. The grand mean of 4.44 suggested that the respondents are performing far above standard (FAS). Rank on the first spot is regular delegation of responsibilities and assign tasks with precision and consideration to the employees. On the second place is there an assurance of equal opportunities for promotions across all employees, regardless of tenure in the organization as long as the employee is efficient and productive with a weighted mean of 4.40. The third rank with weighted mean of 4.39 is to create a structured and personalized career development framework for each employee. This is followed by “assign individuals to roles where their full potential can be effectively utilized (4.36). Least on the rank is equal chance for individual professional growth (4.33). Rahayu (2019) emphasized the relationship of job satisfaction and compensation, employees are well committed if they are receiving salary and benefits proportional to their performance.

Table 4
Level of Commitment of Postmillennial as to Career Development

Indicators	WM	VI	Rank
1. Assign individuals to roles where their full potential can be effectively utilized.	4.36	FAS	4
2. Provide equal chance for individual professional growth.	4.33	FAS	5
3. Regularly delegates responsibilities and assigns tasks to employees with precision and consideration.	4.45	FAS	1
4. Ensure equal opportunities for promotions across all employees.	4.40	FAS	2
5. Create a structured and personalized career development framework for each employee.	4.39	FAS	3
Overall Weighted Mean	4.39	FAS	

Based on the previous tables (1-5), postmillennials shown an excellent level of commitment based on the selected criteria used in the study. This can be attributed to the general behavior of this generation, they can easily adapt to the work environment or they are accustomed to embrace hard work and patience, thinking of there is no option otherwise to resign from work and be a full-time student.

Among the twelve indicators identified as a problem encountered by the working students, four of them are classified as Encountered while the rest is moderate encountered (see Table 5). Rank on the top is current life-balance is not well aligned to the employee's vision in terms of personal and career development in which garnered a mean of 3.80. While decision making with the short-term outlook ranked second with weighted mean of 3.66. The third one is elimination of barriers between various fields of study and policy issues (WM=3.60) and on the fourth spot is lack of time brought on by hectic schedules and overwhelming responsibilities (3.58). This implied that due to their current situation where they need to balance work-school-personal life, these working students find difficulties in managing their time. They need to either choose which needs to prioritize or give up one of them to become productive. Navas (2022) stated the difficulty of spending time doing work and studying because there are days of unbearable circumstances. Problems they encountered associated with their colleagues and supervisor were classified as moderately encountered with weighted mean ranging from 3.00 to 3.34. They also least experienced lack of opportunity for self-development and promotion. Lastly, they rated the lowest among the indicators the problem when it comes to delayed salary, no incentives and bonuses, and poor workplace morale.

Table 5
Problems Encountered on the Level of Commitment of Postmillennial

Indicators	WM	VI	Rank
Decision making with the short-term outlook	3.66	E	2
The elimination of barriers between various Fields of study and policy issues	3.60	E	3
Lack of time brought on by hectic schedules Overwhelming responsibilities	3.58	E	4
Current life-balance is not well aligned to the employee's vision in terms of personal and career development	3.80	E	1
A little to non-support or assistance from the supervisor	3.10	ME	6
Failure to acknowledge accomplishment or prejudice of the employees	3.00	ME	7
Unfair terms and condition and no incentives of employment	2.92	ME	8
Infrequent face-to-face interactions between the team leaders and members	3.34	ME	5
Poor Workplace Morale	2.60	ME	11.5
Delay Salary	2.60	ME	11.5
No commissions and/or bonuses	2.62	ME	10
Lacking opportunity for advancement or promotion at the organization	2.80	ME	9
Overall Weighted Mean	3.14	ME	

Legend:

Scale	Range	Verbal Interpretation	Symbol
5	4.20-5.00	Highly Encountered	HE
4	3.40-4.19	Encountered	E
3	2.60-3.39	Moderate Encountered	ME
2	1.80-2.59	Least Encountered	LE
1	1.00-1.79	Not encountered	NE

The result revealed in Table 6 that the computed t-value is 2.5138 which is higher than the critical value of the 1.812 with 10 degrees of freedom at the 0.05 level of significance. This indicates a significant relationship between the level of organizational commitment of the Generation Z employees and problems encountered. Therefore, the null hypothesis is rejected.

Table 6
Correlation of Level of Organizational Commitment of the Postmillennial Employees and their Encountered Problems

r-value	df	t-value	critical value	Interpretation	Decision
0.64	10	2.5318	1.812	Significant	Reject Ho

CONCLUSION AND RECOMMENDATION

The assessment on the four criteria used to measure the level of commitment of the postmillennial are rated as Far Above Standard (FAS) with a grand mean of 4.44. The level of commitment of postmillennials as to company policy, working condition, salary and benefits, and career development are found to be Far Above Standard (FAS). Most of the problems categorized as encountered are associated with balancing work-school-personal life, which is not easy to resolve otherwise, sacrificing each of them. Moderately encountered problems are related to financial aspects, which indicates that they are well compensated with given opportunity for self-development. The result of statistical analysis suggested that there is a relationship between their level of commitment to organization and the problems encountered.

From the result, this study can recommend to implement a collegial model into the workplace that helps them enhance their learning skills and experiences to apply in real life situations. These generations must learn to balance work-school-personal life. This can be done through collaborative efforts of faculty, school officials and work supervisors to improve their morale and reduce related stresses. Faculty members must show concerns and be lenient to academic requirements, so these working students may feel affection from them.

REFERENCES

- Kaur, M., and Sharma L. (2022). Moderation-Mediation Framework connecting internal branding, affective commitment, employee engagement, and job satisfaction: an Empirical study of BPO employee.
- Kirchmayer, Z. And Fraticova, J. (2020). Generation Z in the need for meaningful work as a key factor in motivation in the organization. https://link.springer.com/chapter/10.1007/978-3-030-43616-2_6
- Lai-Bennejean, C., and Beitelspacher, I. (2020). Impacts of Salespeople's biased and unbiased performance attributions on job satisfaction: the concept of misattributed satisfaction. *European Journal of Marketing*.
- Navas, G. (2022). Is the BPO Industry a wise choice for fresh graduates? <https://villagepipol.com/is-the-bpo-industry-a-wise-choice-for-fresh-graduates/>.
- Rahayu, G. (2019). Pengaruh Kompensasi Terhadap Kepuasan Kerja Pegawai Bagain SDM & Umum PT KAI DAerah Operasi 1 Jakarta. *Journal of Chemical Information and Modeling*, 53(9), 1689-1699.
- Thompson, L. (2020). Covid-19 and the Philippines' Outsourcing Industry. <https://blogs.lse.ac.uk/seac/2020/09/22/covid-19-and-the-philippines-outsourcing-industry/>.

LITERACY ON BASIC CONSUMER RIGHTS: BASIS FOR AWARENESS PROGRAM

Apple M. Rapada

INTRODUCTION

In a world where commerce and consumption intricately shape our daily lives, it becomes imperative to comprehend the rights that safeguard individuals in the market place. Understanding consumer rights is essential for making informed decisions and protecting oneself from unfair practices. Consumer rights literacy empowers individuals to recognize their entitlements, seek redress when wronged, and advocate for their interests. Consumer literacy may be seen as combination of mindfulness, information, ability, demeanor, and behavior vital to form sound budgetary choices and eventually accomplish personal financial well-being. Although there is widespread information on how to be consumer literate, a lot are still confused and find it hard to apply knowledge in choosing the best product.

Consumer Rights is a framework that sets standard to the product about its quality, quantity, potency, purity and its price.

Consumers must also aware of their responsibilities, not only their rights. Critical awareness is first on the roster, which means they must practice questioning the information of a good or service and stay alert against misleading products and the quality of the goods they are acquiring. Second, consumers must act to get a fair deal with manufacturers since passive consumers can become prime targets for exploitation. Third, consumers must also be aware of social concern, which includes knowing of the community, not only on their personal well-being. Fourth, consumer responsibility is being environmentally aware of the consequences of consumption to help the individual practice conservation and sustainability of resources. Lastly, consumers must practice solidarity by organizing themselves to be able to influence, promote, and protect the interest of everyone.

By making the consumer become aware and knowledgeable and practice their rights and responsibilities, they can become responsible and discerning in dealing with the everyday concerns as a consumer and the effects consumerism to human environment.

METHODS

This study used the descriptive-quantitative design which utilized the quota sampling method.

A descriptive research was employed in this study to account the profile and level of Literacy of the respondents on Basic Consumer rights.

The subjects of the study are selected consumers in General Mariano Alvarez, Cavite. A total of 200 respondents from the 4 different barangays.

In gathering data, the main instrument was the survey questionnaire in which the items were constructed based on the specification of the study. The statistical tools used for analyzing the data were frequency, percentage, weighted mean and chi-square.

RESULTS AND DISCUSSION

Table 1
Summary of Assessment on Level of Awareness on Basic Consumer Rights

Variables	Weighted Mean	Verbal Interpretation	Rank
1. Right to Basic Needs	3.55	Often	8
2. Right to Safety	4.01	Often	2
3. Right to Information	3.80	Often	3
4. Right to Choose	3.67	Often	4
5. Right to Representation	3.65	Often	5
6. Right to Redress	3.58	Often	7
7. Right to Consumer Education	3.59	Often	6
8. Right to Healthy Environment	4.04	Often	1
Overall Weighted Mean	3.73	Often	

At glance on the table, the summary of assessment of respondents on the level of awareness on Basic consumer Rights with an overall rating of 3.73 or Often.

On the assessment of the respondents "Right to Healthy Environment" had a rating of (WM=4.04) rank 1; "Right to Safety" (WM=4.01) rank 2; "Right to Information" (WM=3.80) rank 3; "Right to Choose" (WM=3.67) rank 4; "Right to Representation" (WM=3.65) rank 5; "Right to Consumer Education" (WM=3.59) rank 6; "Right to Redress" (WM=3.58) rank 7; and lastly, "Right to Basic Needs" (WM=3.55) rank 8.

As the respondents assess on the level of awareness on basic consumer rights a healthy environment is their core concern which promote healthy and sustainable society.

According to Bello K.B (2020) consumers with higher knowledge of rights will be in a better position to make evaluative judgements about the products and services. Awareness of consumer rights enables consumers to seek redress whenever they are dissatisfied. When consumers are not aware of their rights it is unlikely that they can seek redress whenever they are dissatisfied.

Table 2
Relationship Between Age and Level of Literacy

Variables	p-Value	Hypothesis	Interpretation
1. Right to Basic Needs	0.098	Accept Ho	Not Significant
2. Right to Safety	0.975	Accept Ho	Not Significant
3. Right to Information	0.000	Reject Ho	Significant
4. Right to Choose	0.005	Reject Ho	Significant
5. Right to Representation	0.017	Reject Ho	Significant
6. Right to Redress	0.145	Accept Ho	Not Significant
7. Right to Consumer Education	0.000	Reject Ho	Significant
8. Right to Healthy Environment	0.921	Accept Ho	Not Significant

Level of significance at 0.05

The table shows that there is no significant relationship between age and level of literacy as to the right to basic needs ($p=0.098$); right to safety ($p=0.975$); right to redress ($p=0.145$); and right to healthy environment ($p=0.921$) were all greater than at level of significance at 0.05. Hence, the null hypotheses are accepted. Meanwhile, there is significant relationship between

age and level of literacy as to the right to information ($p=0.000$); right to choose ($p=0.005$); right to representation $p=0.017$; and right to consumer education ($p=0.000$) were all less than at 0.05. Thus, the null hypotheses were rejected.

Table 3
Relationship Between Marital Status and Level of Literacy

Variables	p-Value	Hypothesis	Interpretation
1. Right to Basic Needs	0.519	Accept Ho	Not Significant
2. Right to Safety	0.355	Accept Ho	Not Significant
3. Right to Information	0.079	Accept Ho	Not Significant
4. Right to Choose	0.011	Reject Ho	Significant
5. Right to Representation	0.506	Accept Ho	Not Significant
6. Right to Redress	0.904	Accept Ho	Not Significant
7. Right to Consumer Education	0.000	Reject Ho	Significant
8. Right to Healthy Environment	0.973	Accept Ho	Not Significant

Level of significance at 0.05

The table depicts that there is no significant relationship between the marital status and level of literacy as to the right basic needs ($p=0.519$); right to safety ($p=0.355$); right to information ($p=0.079$); right to representation ($p=0.506$); right to redress ($p=0.904$); and right to healthy environment. Hence, the null hypotheses are accepted. Meanwhile, there is significant relationship between the marital status and level of literacy as to right to choose ($p=0.011$); and right to consumer education were all less than at 0.05. Thus, the null hypotheses were rejected.

Table 4
Relationship Between Sex and Level of Literacy

Variables	p-Value	Hypothesis	Interpretation
1. Right to Basic Needs	0.045	Reject Ho	Significant
2. Right to Safety	0.681	Accept Ho	Not Significant
3. Right to Information	0.648	Accept Ho	Not Significant
4. Right to Choose	0.522	Accept Ho	Not Significant
5. Right to Representation	0.216	Accept Ho	Not Significant
6. Right to Redress	0.133	Accept Ho	Not Significant
7. Right to Consumer Education	0.240	Accept Ho	Not Significant
8. Right to Healthy Environment	0.332	Accept Ho	Not Significant

Level of significance at 0.05

The table shows that there is no significant relationship between sex and level of literacy as to the right safety ($p=0.681$); right to information ($p=0.648$); right to choose ($p=0.522$); right to representation ($p=0.216$); right to redress ($p=0.133$); right to consumer education ($p=0.240$); and right to healthy environment ($p=0.332$) were all greater than at 0.05. Hence, the null hypotheses are accepted. Meanwhile, there is a significant relation between sex and level of literacy as to the right of basic needs with computed p-value if 0.045. Hence, the null hypothesis is rejected.

Table 5
Relationship Between Type of Consumer and Level of Literacy

Variables	p-Value	Hypothesis	Interpretation
1. Right to Basic Needs	0.030	Reject Ho	Significant
2. Right to Safety	0.632	Accept Ho	Not Significant
3. Right to Information	0.256	Accept Ho	Not Significant
4. Right to Choose	0.002	Reject Ho	Significant
5. Right to Representation	0.629	Accept Ho	Not Significant
6. Right to Redress	0.140	Accept Ho	Not Significant
7. Right to Consumer Education	0.090	Accept Ho	Not Significant
8. Right to Healthy Environment	0.207	Accept Ho	Not Significant

Level of significance at 0.05

The table shows the relationship between the type of consumer and level of literacy as to right to basic needs and right to choose with computed p-values of 0.030 and 0.002 rejected the null hypotheses. Thus, there is a significant relationship between the type of consumer and level of literacy as to right to basic needs and right to choose. Meanwhile, there is no significant relationship between the type of consumer and level of literacy as to right to safety; right to information; right to representation; right to redress; right to consumer education; and right to healthy environment with computed p-value of 0.632; 0.256; 0.629; 0.140; 0.090; and 0.207. hence, the null hypotheses are accepted.

CONCLUSION AND RECOMMENDATION

Findings shows that respondents/consumers are tend to prioritize their own safety by evaluating the actual product rather than relying solely on the advertisement. Additionally, consumers are becoming more observant, conscious, and careful on choosing what to buy to minimize the impact of waste in the environment. Moreover, stores valued and empowered the consumers by giving top-most priority and consideration.

It can be noted that there is no significant relationship between the age and level of literacy on right to basic needs, safety, redress, and a healthy environment. However, a significant relationship exists between age and literacy in relation to the right to information, choose, representation and consumer education. Similarly, there is no significant relationship between sex and literacy concerning safety, information, choose, representation, redress, consumer education, and a healthy environment, except for the right to basic needs. Additionally, status does not show significant relationship with literacy, apart from right to choose and consumer education. However, the type of consumer has a significant relationship with literacy for the right to basic needs and the right to choose, while no significant relationship is found for safety, information, representation, redress, consumer education, and a healthy environment.

Considering the findings, it is recommended to enhance the way of teaching the public as to consumer education through proper maximizing information dissemination with use of online platforms.

To improve and develop the awareness and knowledge of the people about consumer rights, it is recommended to make an awareness program through conducting a seminar in every barangay. This will help people in the community to acquire important information that can be use in daily living.

REFERENCE

A. BOOKS

A paradigm shift in Marketing-Creating value for more Sustainable Future (pp. 92-102) Edition: First Chapter: 12 Publisher: PRINCETON PRESS, Overland park, Kansas, USA

Redress Procedures expected by Consumer during a Business-to-Consumer E-commerce dispute (pp. 150-160) Volume 17: Electronic Commerce Research and Applications

B. Online Sources

Chen (2020), Impact of Gender on Consumer Buying Behavior. Retrieved from <https://wkuwire.org/bitstream/20.500.12540/437/1/wkuet>

De Faria (2019). Satisfaction of Basic Needs and Its Repercussion in the course of Development, DOI: 10.1590/1413-8271201940214

Febriana & Irawan (2021). The Influence of Financial Literacy on Bandung Generation-Z Consumers Impulsive Buying Behavior with Self-control as meditating variable. doi:10.35631/AIJBES.39012

Ismail (2020). The importance of consumer education in today's data-driven purchasing journey. Retrieved from <https://www.cmswire.com/contentmarketing/the-importance-of-consumer-education-in-todays-data-driven>

Utkarsh Shukla (2023). Aging and Consumer Behaviors. Retrieved from <https://www.tutorials.point.com/index.htm>

Velaudham (2029). Martial differences towards consumer buying behavior. Retrieved from <https://www.researchgate.net/publication/334733122>

C. Thesis and Dissertation

RK Dewan & Co (2021). Global: Consumer rights. Retrieved from <https://ww.lexology.com/library/detail.aspx?g=1c2>

Sikka (2021). Consumer protection Act: Awareness. Retrieved from <https://ijmnds.org/index.php/ijmnds/article/view/17>

Erratum

EARIST Research Journal, Volume XXIV, No. 35
earist.edu.ph/journal
ISSN 0119-5212

Arrangement of name of authors

In the article “**ON QUARTER SQUARE SEQUENCE**” published in EARIST Research Journal, Volume XXIV, No. 35, Page 25, the name of authors inadvertently switched.

The correct author list should be:

Ramil L. Borres – Enrique Olonan and Associates
Rodora T. Oliveros – Eulogio “Amang” Rodriguez Institute of Science and Technology

In the article “**INVESTIGATING THE CHARACTERISTICS AND RELATIONSHIPS OF THE LEIBNIZ HARMONIC NUMBER**” published in EARIST Research Journal, Volume XXIV, No. 35, Page 29, the name of authors inadvertently switched.

The correct author list should be:

John Martin G. Fontanilla and Joneil G. Pontejos

In the article “**ON PROPERTIES AND RELATIONSHIPS OF THE GENERALIZED PYRAMIDAL NUMBER**” published in EARIST Research Journal, Volume XXIV, No. 35, Page 32, the name of authors inadvertently switched.

The correct author list should be:

Carlos R. Avila and Larex B. Tagalog

In the article “**ON DISMAL ARITHMETIC BOARD GAME**” published in EARIST Research Journal, Volume XXIV, No. 35, Page 38, the name of authors inadvertently switched.

The correct author list should be:

Enrico P. Zara and Larex B. Tagalog

The EARIST Research and Development Services apologizes for any inconvenience that it may have caused. The original article has been updated to reflect these changes.

College Research Project Heads

Ar. John Vincent R. Lopez
CAFA

Dr. Roel P. Balayan
CAS

Dr. Emerson G. Cabudol
CBPA

Mr. Juan Leonardo B. Britanico
CCJE

Dr. Jefferson A. Costales
CCS

Dr. Ailene R. Tuazon
CED

Prof. Meriam L. Tria
CEN

Dr. Jeffrey B. Villena
CHTM

Prof. Joseph Angelo C. Tanuecoz
CIT

Dr. Josephine S. Tuvilla
ECC

Dr. Rogelio T. Mamaradlo
PRESIDENT

Dr. Allan Q. Quismundo
Executive Vice President

Dr. Eric C. Mendoza
Vice President for Academic Affairs

RESEARCH SERVICES STAFF

Dr. Marlene M. Monterona
DIRECTOR

Mrs. Melchorita P. Alvior
EDUCATION PROGRAM SPECIALIST II
In-charge, Journal Reproduction

Engr. Jerome M. Saltorio
EDUCATION PROGRAM SPECIALIST I
In-charge, DOST and IPO Phil Projects

Mr. Richard V. Evangelista
EDUCATION RESEARCH ASSISTANT I
In-charge, Journal Layout and Publication

Mr. Edgardo R. Sison
In-charge, Web Design / Development

Mr. Joseph Calandria
Research Staff

Mr. Marvin V. Lopez
Research Staff

EARIST Research Journal
Volume XXIV, No. 35 ISSN 0119-5212
JANUARY – JUNE 2024

Publication Board

Dr. Eric C. Mendoza
Editor

Dr. Marlene M. Monterona
Associate Editor

Editorial Board

Dr. Jesus S. Paguigan
Dr. Allan Q. Quismundo
Dr. Eriberto R. Astorga, Jr.

Secretariat

Mrs. Melchorita P. Alvior
Mr. Joseph Calandria
Mr. Marvin V. Lopez

Circulation Manager/Lay-Out Artist
Mr. Richard V. Evangelista

Web Design/Development
Mr. Edgardo R. Sison



Republic of the Philippines
EULOGIO "AMANG" RODRIGUEZ
INSTITUTE OF SCIENCE AND TECHNOLOGY
Nagtahan, Sampaloc Manila



The EARIST Innovation and Technology Support Office (EARIST-ITSO) is one of the franchise patent libraries of the Intellectual Property Office, Philippines (IPO-Phil). Its main objective is to advocate the protection of intellectual property on the academe sector. Its strategy is to have a demystified, democratized, and development-oriented patent system, easy to understand by technical people and laymen, to remove the fear of disclosing their intellectual property and eventually registering them for their own protection.

A demystified patent system is evidenced by the fact that majority of the knowledge generators, researchers, and R and D proponents in the country know how to access global scientific and technology information through the patent databases, and when they wish to protect their innovations, they will know how to obtain patents.

A democratized patent system means that patents is an interdisciplinary concern involving business, researchers, engineering, scientists, faculty, students, government, lawyers and other professions, who will know about and use the patent information, engage in patenting activities and participate in technology commercialization.

A development-oriented patent system implies that the patent system is fashioned as an effective tool to bring progress and prosperity, purposely tailored-fit to the particular needs of, and readily accessible by those who want to use patent information and obtain patents.

Services Offered:

- **Conduct Seminars and Trainings**
- **Patent Database Search**
- **Patent Drafting**
- **Assistance for Commercialization of Technology**

**Contact Nos. (02) 8243 9467 / 8243 9460 / 8243 9466 /
8243 9468 / 8243 9437 Loc. 117**



**TECHNOLOGY INNOVATION
AND
SUPPORT OFFICE**