

Republic of the Philippines
EULOGIO "AMANG" RODRIGUEZ
INSTITUTE OF SCIENCE AND TECHNOLOGY
Nagtahan, Sampaloc Manila

VOLUME XXI, No. 29

ISSN 0119-5212

JANUARY - JUNE 2021



EARIST RESEARCH JOURNAL

*"Resiliency in Adapting Technology
Amidst the Covid 19 Pandemic"*



The EARIST Research Journal seeks to further the discussion, advancement, and dissemination of research, planning, development and production concerns and knowledge along professional, scientific, technological, technical and vocational instruction and training in trades, business, arts, sciences and technology.

The opinions expressed in the articles are those of the author or authors; they are not necessarily the views of Eulogio “Amang” Rodriguez Institute of Science and Technology, and the Office of the EARIST Research Services.

Correspondence concerning contributions, subscriptions, advertising, permission to reprint the articles, and other business matters should be addressed to EARIST Research Services.

FOREWORD

The Eulogio “Amang” Rodriguez Institute of Science and Technology takes pride in publishing Volume XXI, No. 29, January – June 2021 of the EARIST Research Journal as it contributes to the attainment of EARIST’s Mission, Vision, Goals, and Objectives through scholarly publications.

This volume is the output of researches conducted by EARIST faculty during the Academic Year 2021. This volume highlighted Twenty-Three (23) distinct researches in different fields, but most noteworthy, each individual research achievement.

The topics vary as shown in every page, but each is full of diverse stories confirming happenings in every college of the Institute. The office of research hopes to mirror the activities of our educators in assuming their task as researchers.

There are more challenges left in the various fields waiting for further scrutiny. We continue the never ending cycle of the quest for new knowledge and further understanding of the issues at hand. The work remains unsolved. But unless we produce our own solutions to existing problems, the challenges will never be met.

The research work undertaken by faculty members and staff are included with the hope that these will contribute to the advancement of research activities of the institute and will serve as medium in the dissemination of research outputs to the community.

Engr. Rogelio T. Mamaradlo
Director, Research Services

TABLE OF CONTENTS

FOREWORD	i
TABLE OF CONTENTS	ii
TECHNICAL RESEARCH	1
CAMPUS STREET LIGHT POWERED BY RENEWABLE POWER SOURCE: SOLAR PANEL	2
<i>Rolf Irwin C. Dangla Cruz</i>	
AI WINDOW TYPE AIRCON CONTROLLER	6
<i>Jose C. Felipe Jr.</i>	
DEVELOPMENT AND EVALUATION OF PORTABLE TOOL BIT SHARPENING HOLDER FOR BENCH GRINDER	9
<i>Eldon P. Perez, Nacho B. Amac, and Jordan A. Datu</i>	
CHARACTERISTICS OF ARITHMETIC DERIVATIVE TO SOME INTEGER SEQUENCES	14
<i>Joneil G. Pontejos and Roel P. Balayan</i>	
FACE SHIELD WITH BODY TEMPERATURE SCANNER AND RECORDING SYSTEM	19
<i>Edgardo R. Sison</i>	
BEHAVIORAL RESEARCH	23
EFFECTS OF TEXT MESSAGING ON THE SPELLING AND VOCABULARY SKILLS OF SELECTED FRESHMEN STUDENTS: BASIS FOR SCAFFOLDING ACTIVITIES FOR SOCIAL SCIENCE ACADEMIC WRITING	24
<i>Arnold O. Adante</i>	
PAGBUO NG GENDER NEUTRAL GUIDELINES SA PAGGAMIT NG WIKANG FILIPINO SA DIGITAL NA TALASTASAN	39
<i>Joseph C. Anggot</i>	
ONLINE NA PAGTUTURO NG FILIPINO: MGA HAMON AT ESTRATEHIYA.	45
<i>Dr. Eriberto R. Astorga Jr.</i>	
ASSESSMENT OF STUDENT ENGAGEMENT AND DELIVERY OF INSTRUCTION IN HIGHER EDUCATION: BASIS FOR FLEXIBLE LEARNING PROGRAM	52
<i>Daisy Mae R. Bongtiwon, Derick O. Peralta, Centrey L. Ramos, and Elsa R. Cagatan</i>	
APPLICATION OF WORK FROM HOME SCHEME DURING PANDEMIC AND IT'S SIGNIFICANCE TO EARIST CBA FACULTY: BASIS FOR WORK PRODUCTIVITY	58
<i>Dr. Aguida V. Cabrerros</i>	

IMPLEMENTATION OF THE HEALTH AND SAFETY GUIDELINES IN SELECTED BUDGET HOTELS IN THE NEW NORMAL	62
<i>Kristine joy Castro, Mary Grace C. Santos, and Moresa Joy Gregana</i>	
PERSONNEL POLICIES IN MANILA TRAFFIC AND PARKING BUREAU OF THE CITY GOVERNMENT OF MANILA: AN ASSESSMENT	72
<i>Diana P. Dela Cruz and Erick P. Mante</i>	
SAFETY MEASURES IMPLEMENTED BY SELECTED QUICK SERVICE RESTAURANTS IN MUNTINLUPA CITY	82
<i>Maria Rhoda D. Dinaga</i>	
STATUS OF INTER-FAITH SERVICE AND ITS PROMOTIONAL STRATEGIES IN EARIST SCALE CONSTRUCTION FIRMS IN FIRST CLASS CITIES IN METRO MANILA: BASIS FOR FULL IMPLEMENTATION.	92
<i>Ronaldo F. Doroteo</i>	
PHYSICAL PLANT AND FACILITIES AND ITS RELATIONS TO STUDENT ACADEMIC PERFORMANCE: BASIS FOR COLLEGE MODERNIZATION PROGRAM	99
<i>Estrelita S. Glodo, Fernando N. Filler, and Irma F. Filler</i>	
EMPLOYEE PERFORMANCE APPRAISAL SYSTEM AND ITS RELATION TO INDIVIDUAL PERFORMANCE RATING COMMITMENT: BASIS TO COLLEGE INTERVENTION MEASURED	104
<i>Ma. Lourdes H. Gomez</i>	
RECORD MANAGEMENT SYSTEM FOR SENIOR CITIZENS IN GENERAL MARIANO ALVAREZ, CAVITE	116
<i>Eugene Paolo Z. Guades, Catherine D. Dumpit, and Gerlyn M. Domingo</i>	
A STUDY ON PARENTS PERSPECTIVE ON TREATMENT OF CHILDREN UNDER INVESTIGATION FOR VIOLATION OF ORDINANCE	122
<i>Felipe K. Jamero, Richard K. Jamero, Romeo B. Capucao, Derick O. Peralta, and Roger D. Ramos</i>	
THE BENEFITS AND RISKS OF MOBILE PALENGKE IN PASIG CITY AND ITS SUSTAINABILITY	131
<i>Evan John S. Magno</i>	
ENTREPRENEURIAL PRACTICES AMONG WOMEN IN BARANGAY 634 BASIS FOR SCHOOL AND COMMUNITY ENTREPRENEURIAL PARTNERSHIP PROGRAM	138
<i>Dr. Anna Victoria V. Mailas</i>	
TEACHERS' PHILOSOPHICAL PERSPECTIVES AND THEIR CURRICULUM ENGAGEMENT: TOWARDS ARTICULATING A PHILOSOPHY OF TEACHING	142
<i>Dr. Eric C. Mendoza</i>	

AWARENESS ON LOCAL POLICE HOTLINE NUMBER OF THE RESIDENTS OF SELECTED BARANGAY IN GEN. MARIANO ALVAREZ, CAVITE	147
<i>Edzel G. Peña and Dr. Shirley P. De Leon</i>	
PHYSICAL PLANT AND FACILITIES ITS RELATIONS TO STUDENT ACADEMIC PERFORMANCE: BASIS FOR COLLEGE MODERNIZATION PROGRAM	155
<i>Dr. Chanda R. Tingga</i>	

The background is a complex digital collage. It features a central network diagram with glowing blue nodes and connecting lines. Surrounding this are various data visualization elements: a bar chart at the top left, a world map in the top right, a globe in the bottom left, and several smaller charts and graphs scattered throughout. The overall color palette is dominated by warm oranges and browns, with bright blue highlights from the network nodes.

Technical Research

CAMPUS STREET LIGHT POWERED BY RENEWABLE POWER SOURCE: SOLAR PANEL

Rolf Irwin C. Dangla Cruz

INTRODUCTION

With the Intensification of energy crisis all over the world, a project called, "Campus Street Light Powered by Renewable Power Source: Solar Panel" was developed.

All the countries are looking for the ways to solve this serious problem. One way is to search the new energy and to take advantage of the renewable source and another way is to exploit the new energy-saving technologies to reduce energy consumption, and to improve utilization efficiency of energy.

Solar energy is the most common, direct and clean energy on the planet we have already found until now. The solar resources can be seemed inexhaustible. LED is a solid state semiconductor device which can convert electrical energy into visible light. It is characterized with small size, low power consumption, long service life and environmental friendly. The spectrum of the LED is a mostly concentrated in the visible light spectrum, so it has a high luminous efficiency which can be described as the great reform in the solid light source. This essay briefly describes the solar led street lighting system. It uses the solar radiation energy to charge the battery with the solar panel during day time, and offer energy to the LED light equipment at night. This system has a double advantage in both utilization of new energy and energy-saving.

One of the most used in the world is power source. Solar panel has become an important alternative energy source in every part of the world because it helps the people use electricity by the use of sunlight that absorbs by the panel and make it an alternative power source to supply in the household, schools/universities and other industrial building. In the business industries and government facilities like schools/universities, they want to minimize the expenses in electricity bill as much as possible. With the use of solar panel, they will be able to conserve energy and reduce their electrical bill which will help them to minimize their expenses.

BACKGROUND OF THE STUDY

People now a day think of ways to find alternative power source that would help them to make life easier. The introduction of solar energy to our new technology has given an alternative for people who don't have access electricity provided by private companies. Solar energy can produce electricity for households, school communities and supply power for equipment such as telecommunication, machines and most especially for our lights.

The researchers try to innovate the common power source using Photovoltaic device which will help conserve consumption in power source, save fund in electric bills, and then make the sunlight as an alternative source of energy to generate electricity.

This is an actual practice of putting theory into application through the production of a dynamic innovation of a product that may help people conserve energy.

According to Becker 15.9 Giga watts of solar photovoltaic system installations were completed with solar photovoltaic pricing survey and Market Research Company's photovoltaic insights reporting growth of 117.8% in solar photovoltaic installation in a year basis. Based on our study that photovoltaic / solar panel is a term which covers the conversion of light into electricity using semiconducting materials that exhibit the photovoltaic effect, a phenomenon studied in physics.

After hydro and wind power, photovoltaic is the third renewable energy source in terms of global capacity in 2014 worldwide installed photovoltaic capacity increased to 177 Giga watts which is two percent of global electricity demand. China followed by Japan and the United States, is the growing market while Germany remains the world largest producer, with solar Photovoltaic providing 7% of annual domestic electricity consumption.

Based on this study the photovoltaic is very useful. Many of the researchers typically observed solar panel during every day activities.

One example is a calculator that may seem to work for a long time even though they did not put any batteries in it. In additional, a large number of solar panel was spotted outside of the city. Solar cells take advantage of the unlimited availability of the sun's rays which reaches the planet in every second.

They are readily seen and it has certainly grown to be a part of humans' everyday life.

The calculators and the solar panels that the researchers saw on familiars' house are photovoltaic cells.

The advantage of photovoltaic is to provide clean-green energy. During electricity generations with photovoltaic panels, there is no harmful greenhouse gas emission; thus, solar photovoltaic is environmental friendly. The solar energy supplied by nature is free and abundant. It can also be available anywhere with the presence of sunlight. Photovoltaic panels through Photo electric phenomenon produced electricity in a direct way. The residential solar panels are easy to install on rooftops or on the ground without any interference to residential life style.

As in renewable energy source, solar energy has intermittency and unpredictability that makes its panels less reliable as a solution. Solar Panel also needs additional equipment such as inverter to convert direct electricity to alternating electricity in order to use the power. It also needs batteries to increase the investment cost for photovoltaic panels considerably. In addition, solar panel cannot be used in rainy and cloudy season. It will not charge some sunlight that is needed to generate power supply in the load; thus, making it incapable of doing its work.

Materials Needed

Set of Solar Panel (base on the Need of load)

Battery

Electrical Wiring

Inverter

Circuit Breaker

Frame for Solar Panel

Note:

The Total Quality of the Material is depending of the Total load required. (Ask for the Professional Assistance for the Design).

SIGNIFICANCE OF THE STUDY

For Institute

This study will help the Institute to lessen the consumption of electric bill, make a campus powered by renewable source.

For Environment

The study helps to replace fossil fuel as the major energy source because solar power is renewable at absolutely no cost to supply energy infinitely. Moreover, solar panels are able to harness the energy from the sun and convert it to electricity.

For Future Researcher

The project can serve as an important tool to those who will conduct studies related, learning references by providing information broadening the knowledge in creating better results in the same field study. It also helps the future researchers to improve their project and also, it can serve as a guide to them.

SUMMARY OF FINDINGS

The project was developed through the integration of the different components consisting of the following Solar Panel (REC Solar 265W), End clamp, L – feet, MC4 Connector, Mid Clamp, Rails, Rails splice and Silicon which were mounted in the roof of Industrial Technology Center Building (ITC Bldg.).

A part of the study was concerned with the specification and computation of the solar panel to be use, mounting/installed and connection of the solar panel, description of the project, the tools used and the procedure in the making of the project. It included the working drawing, diagramming and picture specifications, List of materials, steps in operating the project, preventive maintenance, safety and control measure and some trouble shooting techniques to guide the operations.

CONCLUSION

This paper showed the feasibility for the teacher and students of Electrical Technology courses, to compute, mount and to install of solar panel that can be used in performing the campus street lights and flood alarm. This study provides information regarding the development of solar panel/photovoltaic. The result of this study should serve as a leap toward another technical innovation in line to electrical servicing.

The Campus Street light installed in the College of Industrial Technology was so helpful to the student and Barangay.

Us the part of this the Administrative of the Eulogio “Amang” Rodriguez Institute of Science and Technology may Implement the Solar panel to all the Building in the Institute and Connect all the lighting system in the EARIST.

BIBLIOGRAPHY

https://en.wikipedia.org/wiki/Solar_panel

https://en.wikipedia.org/wiki/Solar_cell

<https://www.rappler.com/business/industries/173-power-andenergy/31969-renewable-energy-is-sustainable-competitivestudy>

<http://opinion.inquirer.net/97095/case-ph-transition-solarenergy>

<http://www.nwwindandsolar.com/solar-power-in-seattle-andthe-northwest/how-do-solar-systems-produce-energy/>

http://www.dlsu.edu.ph/library/pathfinder/eng_tech/solar_energy.asp

https://www.ashden.org/sustainable-energy/ashdenguides/solar-for-thegrid?gclid=EAlaIqobChMluKXBmbnR1gIVgpO9Ch3P6g4GEAAAYAiAAEgJhOPD_BwE

<https://www.vivintsolar.com/learning-center/how-does-solarpower-work>

<https://www.vivintsolar.com/learning-center/what-is-netmetering>

AI WINDOW TYPE AIRCON CONTROLLER

Jose C. Felipe Jr.

RATIONALE

The most problem on a household in terms of room temperature is by going to turn on the ac unit. AC unit will change the room temperature in a couple of minutes but turning on is now that easy. An AC unit that have a conventional dial settings to adjust the selector from fan to turbo cool and thermostat from 1 to 10 will take time to take to the turbo cool and high on thermostat. Once the ac unit is on the turbo cool and thermostat 10 and you feel that is very cold in the room you will stand up to adjust it manually.

A proposed AI Aircon Controller will change the way to turning on an AC unit. The AI Aircon Controller well the one to automatically adjust all the settings unlike the conventional dial settings. The AI Aircon Controller will check the room temperature and will adjust automatically for the right room temperature not to very cold.

The importance of the proposed topic is the user will no longer to adjust all the settings unlike on the conventional dial ac unit. The ease of doing one touch of turning the ac unit will have greatly an advantage. The proposed topic will have much more efficient on the consumption of electricity.

TECHNICAL PREVIEWS

The PIC microcontroller is responsible for the control of the object system. It takes input/output of data, selects and controls of peripheral IC, communication control of data and executes the program. It has flash program memory and EEPROM, so it can modify and extend the program. In addition, it has function of A/D conversion that coverts direct analog value into digital value and calculate data. Therefore, the PIC microprocessor chip having such functions is possible to simplify the existing complicated peripheral circuits to design the entire system easily. In this study, we design the AC power controller using PIC microcontroller and traic. Through the change of A/D value input directly to the microprocessor, the power controller was verified by experiment to control brightness of the incandescent lamp. As a result, it is confirmed that the AC power controller is well-controlled by phase control employing PIC microcontroller and traic [1].

Motivation for proposal: There is the well-known First Benchmark Model for (Classic!) HVDC Control Studies by Szechtman, Wess and Thio (Elektra 135, April, 1991). and a later proposal for revised configuration and parameters prepared by SC 14 (1993). The SCR is 2.5 on both converter sides. While the latter model permits to study resonances and commutation failure behavior, and controls can be designed and tested versus this benchmark, the model does not permit to study the transient effect of inertia - size and location on both transmission ends - and of AC transmission in parallel. However, this is particularly essential at very low SCR as the here given 2.5. Besides this the applied constant gamma controller in the First Benchmark is not state of the art. Whether it is also applied in the a.m. later CIGRE Benchmark is not clear. In the seventies of the last century there was a non-patented invention by the author of this site, already addressing the present day problem of automatic power sharing between AC and DC transmissions, that time in the context of a Hybrid AC/DC Transmission being investigated for the use of Bulk Water Power Resources in developing countries. For

studies on the power oscillation damping effect of the needed AC/DC power sharing controller a linear state space model was generated (see author's thesis on this site) and a 2 kW Hardware Transmission Model with Closed Loop Microprocessor Control of the AC/DC power flow was built. Recently resuming this work the hardware setup and the control algorithm is now transferred to the PSCAD transient simulator. While the first motivation of the work was to find out the effect of power sharing control versus frequency feedback for large fault excited disturbances in hybrid ac/dc transmission - excluded in the original work - the idea came up to propose simultaneously a new Classic HVDC/AC Transient Controls Benchmark permitting to investigate various power oscillation damping methods and the respective handling of short circuits faults on either transmission end. This is a logical extension of work. It combines research and practical experience after being many years in the respective industries building and commissioning HVDC systems. Essential results obtained from the now proposed benchmark: 1. Damping inter-area oscillations through AC/DC power sharing control can substitute relative frequency feedback or phase angle derivative feedback. Very important: In addition to stabilization it provides an immediate reduction of DC power at large load rejection without needing a trigger signal from a protection relay. This prevents destabilizing power flow reversal in parallel AC paths. This transient control is not available with frequency or phase angle derivative feedback. 2. No remote measurements and signal transmission of frequency or phase angles are needed at power sharing control. 3. As it is already known and here confirmed: Use of the derivative of AC power for damping is critical. The initial pulse generated goes into the wrong direction. This is the same problem as with single frequency feedback. 4. Inherent very important feature: In power sharing control the AC power is normalized with regard to the feedback signal generated and, therefore, the method works over a wide power range from minimum to maximum AC power. The DC power is used in the power sharing formula $k = P_{dc} / (P_{dc} + P_{ac})$. There is a reference value k_{ref} and an actual value k . The reference value k_{ref} is a function of the total power $P_{dc} + P_{ac}$. With the total power increasing k_{ref} must decrease in order to stabilize the transmission system. I.e., the gradient of k_{ref} is negative. Special Feature: Use of the fundamental "two-area but 4-node system" to account for the impedance between the center of grid inertia and the DC terminal connections. This permits to study the proximity or remoteness of PMUs from the center of inertia and the location of HVDC converter terminals. The linear state space model includes AC and DC as well as its coupling through power sharing control. To study the effect of the so dimensioned controller at large impacts on power system structure and operating point shifts the digital simulator PSCAD is used. Interesting and important results: Controller feedback gains determined in the linear Matlab model keep their validity over a wide range of operating points in the transient PSCAD model even at short circuit faults with dropout of AC lines. 5. The available linear model permits to study and compare BES power oscillation damping with HVDC power modulation using the various before mentioned methods [2].

The study continues the theoretical derivation from Part 1, and the experiment is carried out at a bus station equipped with six water-cooled chillers. Between 2012 and 2017, historical data collected from temperature and humidity sensors, as well as the energy consumption data, were used to build artificial intelligence (AI) assisted heating ventilation and air conditioning (HVAC) control models. The AI control system, in conjunction with a specifically designed prior information notice (PIN) sensor, was used to improve the prediction accuracy. This data collected between 2012 and 2016 was used for AI training and PIN sensor testing. During the hottest week of 2017 in Taiwan, the PIN sensor was used to conduct temperature and humidity data predictions. A model-based predictive control was developed to obtain air conditioning energy consumption data. The comparative results between the predictive and actual data showed that the temperature and humidity prediction accuracies were between 95.5 and 96.6%, respectively. Additionally, energy savings amounting to 39.8% were achieved compared to the theoretical estimates of 44.6%, a difference of less than 5%. These results show that the experimental model supports the theoretical estimations. In the future, a PIN

sensor will be installed in a chiller to further verify the energy savings of the AI assisted HVAC control [3].

DESIGN CONCEPT

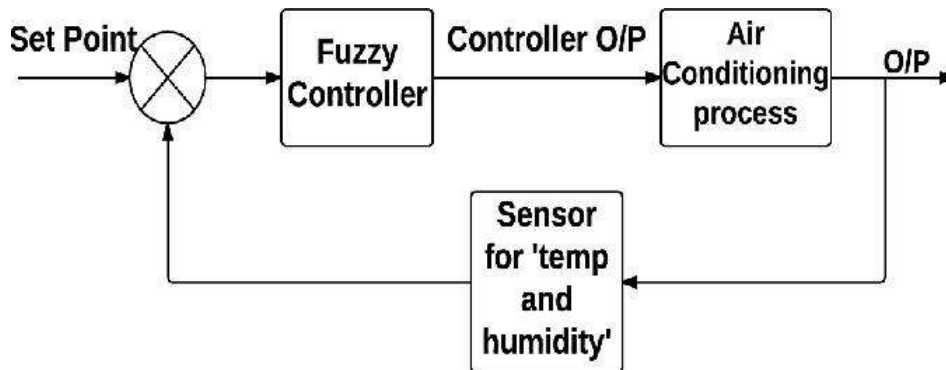

REFERENCES

- [1] Ji, Sang & Han, Seung. (2021). A Study on the AC Power Control Using PIC Microcontroller. 10.1007/978-3-030-53021-1_13.
- [2] Kuehn, Walter & Sadek, Kadry. (2020). Proposal for a New HVDC/AC Controls Benchmark. 10.13140/RG.2.2.20248.42248.
- [3] Cheng C-C, Lee D. Artificial Intelligence Assisted Heating Ventilation and Air Conditioning Control and the Unmet Demand for Sensors: Part 2. Prior Information Notice (PIN) Sensor Design and Simulation Results. *Sensors*. 2019; 19(15):3440.

DEVELOPMENT AND EVALUATION OF PORTABLE TOOL BIT SHARPENING HOLDER FOR BENCH GRINDER

*Eldon P. Perez
 Nacho B. Amac
 Jordan A. Datu*

INTRODUCTION

Bench grinder is a bench top type of a grinding machine that is used to drive abrasive wheels (Wikipedia). It is a tool for spinning grindstones that are gently shaping metals. It is commonly used for getting blunt tools back to full sharpness using either a very fine grit or a sharpening steel (Everard, 2019). Bench grinders are standard equipment in metal fabrication shops and machine shops, as are handheld grinders (Wikipedia). A tool bit is a non-rotary cutting tool used in metal lathes, shapers, and planers. Such cutters are also often referred to by the set-phrase name of single-point cutting tool, as distinguished from other cutting tools such as a saw or water jet cutter.

The cutting edge is ground to suit a particular machining operation and may be sharpened or reshaped as needed. The ground tool bit is held rigidly by a tool holder while it is cutting. A tool holder is a type of jigs and fixtures that holds the tool bit. This study intends to develop a portable sharpening tool bit holder for bench grinder to produce bits with appropriate angles for cutting steel. This portable sharpening tool bit holder is easy to build.

It is quick and easy for beginners and experts to grind bits. These are bits for quickly removing material as well as bits for improving the finish after roughing. This is useful for common external roughing and finishing bits. The bits produced should be oriented exactly perpendicular to the work. This simple holder allows new users to grind bits that work well without spending a lot of time understanding the various angles. In State-Colleges and University, this machine is being used by the teachers that are under the College of Industrial Technology to properly demonstrate and show to the students how this equipment works and how to use it as part of the course specifically, Students under Mechanical Technology

RESEARCH PARADIGM

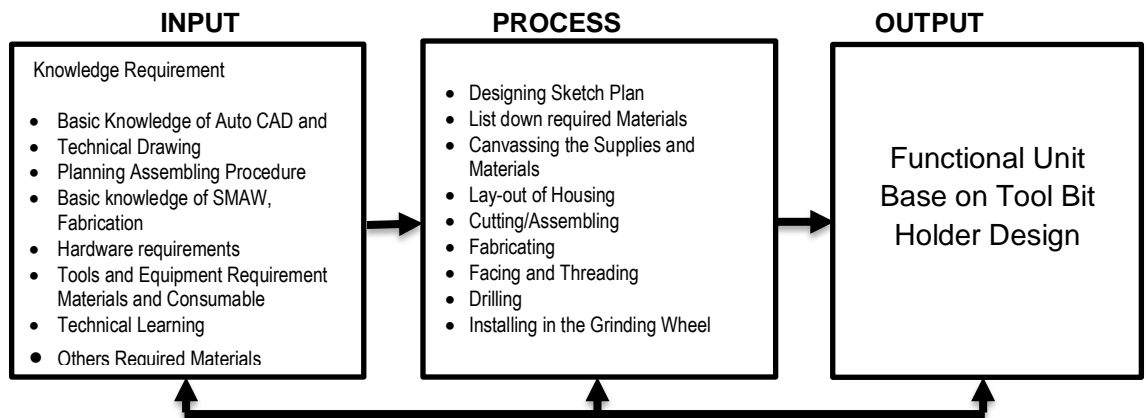
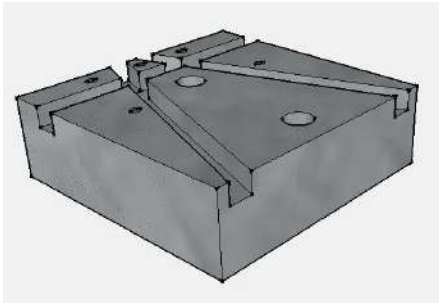
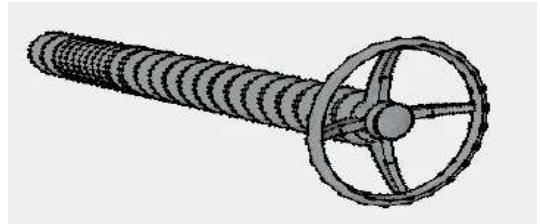
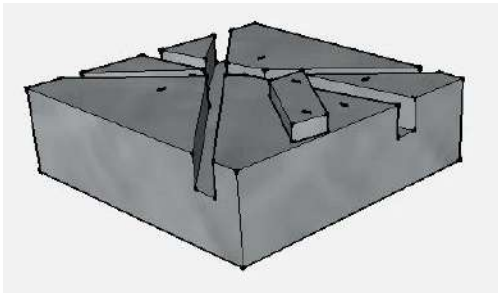
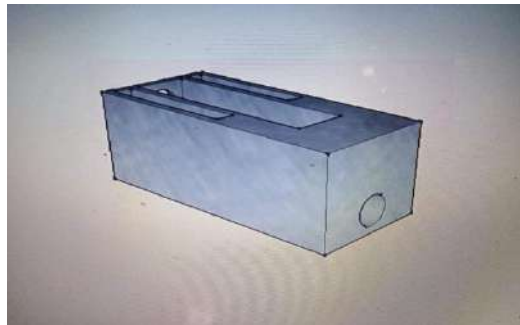
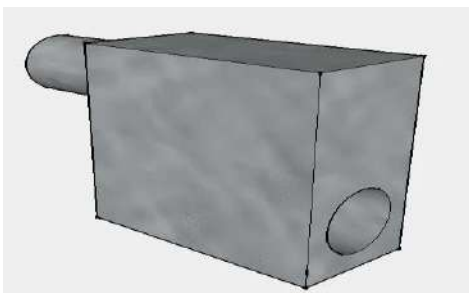
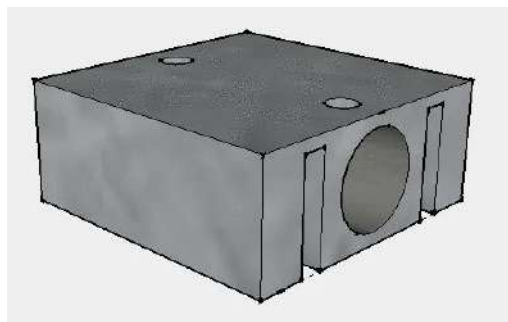

Figure 1. Conceptual Framework of Development of a Portable Sharpening Tool Bit Holder for Bench Grinder

PROJECT DESIGN

The study was undertaken to construct and develop the Portable Tool Bit Sharpening Holder for Bench Grinder. The product of study will be constructed and developed through basic machining operations such as milling, grinding and drilling. This attachment will be beneficial to instructors and students in terms of education and learning. They will be familiarized in grinding particularly in sharpening the tool bit. Additionally, the small-scale machine shop will greatly benefit in the study. The attachment will serve them with great performance and production in a low cost or capital.

ATTACHMENT**HAND WHEEL****ATTACHMENT****FRAME****DRIVEN****BASE**

FINAL PRODUCT

Figure 2: Project drawing plan such as dimension and other important details.

MATERIALS AND METHODS

The construction of the tool bit holder, uses these materials, flat bar, shafting, screws, hand wheel, knots, screws and it is designed to be easy to carry and easy to move, and it is also quick to disassemble or unpack. if needed. The data gathered in this research were from 3rd year student of bachelor in industrial technology taking up Machine Shop Technology who is officially enrolled at Santa Mesa, Manila Eulogio Amang Rodriguez Institute Technology during the year 2020 to 2021. We also gathered data from the machine shop technology instructor in total there are 11 students and 1 instructor to compromise the group of the evaluation of the study. The researchers ask permission to Santa Mesa, Manila Eulogio Amang Rodriguez Institute Technology office to supply the actual number officially enrolled in 3rd year level major in Machine Shop Technology.

After knowing the actual number of the respondents' students, the researchers distribute the evaluation checklist to the evaluator. Permission to conduct a survey was the first enough from the different other department. After evaluation process, the researchers tie the evaluation results to know if the Portable tool holder for bench grinder is acceptable.

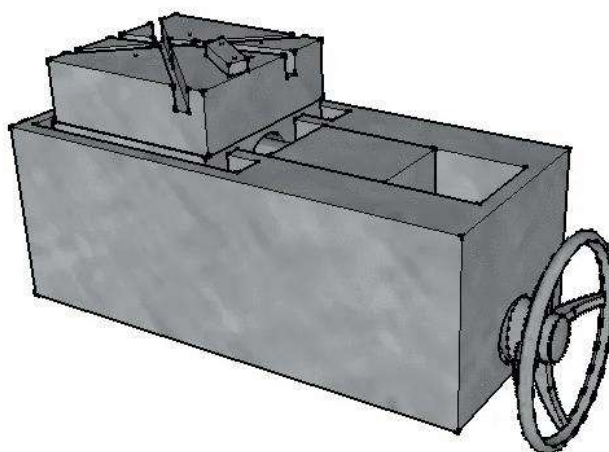
Table 1
List of Required Materials

Items	Specifications	Quantity
1.	FLAT BAR 1"x1"x 20'	10 PCS
2.	HAND WHEEL 4" dia.	1 unit
3.	SHAFTING 1" dia. X 9"	1 PC
4.	SQUARE BAR 3" x 3" x 1.5"	1 PC
5.	SCREW 4 mm	6 PCS
6.	DRILL BIT 4 mm	1 PC
7.	GRINDING WHEEL 6" dia.	2 PCS

The project has been evaluated through the use of evaluation criteria.

RESULTS AND DISCUSSIONS

Table 2
Summary Table of the Assessment of the Two Groups of Respondents on the Level of the Acceptability of Development of:

CRITERIA	INSTRUCTORS		STUDENTS		COMPOSITE MEAN	
	M	VI	M	VI	M	VI
PARTS/STRUCTURE	4.17	A	4.47	A	4.47	A
COST OF THE PROJECT	4.17	A	4.54	HA	4.35	A
COST OF THE MAINTENANCE	4.50	A	4.57	A	4.53	A
FUNCTIONALITY	4.33	A	4.58	HA	4.46	A
SAFETY AND SECURITY	4.33	A	4.44	A	4.39	A

Legend:

Scale	Range	Descriptive Value
5	4.50 – 5.00	Very High Acceptable (VHA)
4	3.50 – 4.49	High Acceptable (HA)
3	2.50 – 3.49	Acceptable (A)
2	1.50 – 2.49	Fairly Acceptable (FA)
1	1.00 – 1.49	Not Acceptable (NA)

The table 2 presents the summary of respondents' evaluation in Portable tool bit sharpening holder. It can be gleaned from table 8, that 5 out of 5 items were rated accepted with weighted means of 4.17, 4.17, 3.50, 4.33 and 4.33 by the instructors. It also shows that 3 out of 5 items were valued as highly accepted with weighted means of 4.47, 4.54, 3.57, 4.58 and 4.44. Then, the grand weighted mean was 4.10 for the instructors and 4.32 for the students. They both agreed that the Portable tool bit sharpening holder is accepted.

CONCLUSIONS

The researchers arrive at the following conclusions based on the findings of the study.

- 1.The Portable Tool Bit Sharpening Holder for Bench Grinder is possible to develop.
- 2.The Portable Tool Bit Sharpening Holder for Bench Grinder had demands in the market.
- 3.The Portable Tool Bit Sharpening Holder for Bench Grinder can reduce the effort consumption at work.
- 4.The Portable Tool Bit Sharpening Holder for Bench Grinder can reduce the variation of products.
- 5.The Portable Tool Bit Sharpening Holder for Bench Grinder is convenient and easy to move.

RECOMMENDATIONS

In view the findings and conclusions the following recommendations are hereby propose:

1. Need's improvement in the design of the product in terms of parts/structure
2. Need to add graduation for better accuracy and for critical operations.
3. Possible to develop with a different handling system.
4. It is possible to construct in more durable material such as 4140 metal or Tool steel.

REFERENCES

- Krar, Gill&, Smid, (2003) A bench grinder is a bench type of grinding machine used to drive abrasive wheels. https://en.wikipedia.org/wiki/bench_grinder#CITEREFMachinery'Handbook1996.
- Materia and Rio de Janero (2007) sharpening aims to provide shape either to new cutting tools and worn ones. http://www.researchgate.net/publication/315381705_Contribution_to_the_sharpening_operation_of_HSS_single_point_cutting_tools.
- JG (2007) this study guide will cover the major working parts, functions, and machining techniques that can be found/used on most pedestal grinders. <https://www.aps.anl.gov/files/apsuploads/safety-and-training/safety/Reference-material/APSPedestalGrinder.pdf>.
- ILO content manager (2011) Grinding generally involves the use of a bonded abrasive to wear away parts of a work piece. <https://www.iloencyclopedia.org/part-xiii-12343/metal-processing-and-metal-working-industry/item/680-grinding-and-polishing>
- Bojan Niceno and Yohei sato (2011) A conservation local interface sharpening scheme for the constrained interpolionprofilmedthod. https://onlinelibrary.wiley.com/doi/abs/10.1002/fld.2695?fbclid=IwAR1B7_bn3miut4ljsu2jy5x0uv9z4pad_bjfef8fb92qh_fqr08dnosy

CHARACTERISTICS OF ARITHMETIC DERIVATIVE TO SOME INTEGER SEQUENCES

Joneil G. Pontejos
Roel P. Balayan

INTRODUCTION

The theory of numbers has always occupied a unique position in the world of mathematics. This is due to the unquestioned historical importance of the subject. Nearly every century since classical antiquity has witnessed new and fascinating discoveries relating to the property of numbers; and, at some point in their careers, most of the great masters of the mathematical sciences have contributed to this body of knowledge.

Many discoveries in number theory are very interesting because of their relationships to other field in mathematics. In consequence, math readers enhance their mind to become enthusiastic and creative in proving theorems and exploring the different areas of number theory.

One of the most fascinating relationships between number theory and analysis is a function that allows the differentiation rules or Leibnitz rule on the set of natural numbers. According to Victor Ufnarovski in 2003 at the journal of integer sequences discussed the concept of differentiation as a function that maps from the set of whole numbers to the set of natural numbers that exhibits some properties of usual differentiation in real valued function x .

In this study, the researcher has expounded and extended the properties of function which holds Leibnitz rule on natural number and uses concept to other type of number sequence.

METHODOLOGY

Descriptive and expository methods of research were used to provide proofs to existing properties and provided new knowledge on the arithmetic derivative of other integer sequences.

RESULTS AND DISCUSSION

The following results of the study are as follows:

1. Properties of Arithmetic Derivative of natural number

1.1. Theorem 3.2.1(Power Rule). Let $n = p^k$ for any prime p and nonnegative integer k , then

$$n' = kp^{k-1}$$

Proof:

Using induction, let $k = 0$ such that $n = p^0 = 1$, then by definition 3.1.2 $n' = 0$.

If $k = 1$, then $n = p$ implies that $n' = 1$ by definition 11

Suppose that the statement is always true for $k = m$ such that $n' = (p^m)' = mp^{m-1}$.

We need to show that for the next positive integer $k = m + 1$ is also true. That is

$$\begin{aligned} n' &= (p^{m+1})' \\ n' &= p^m \cdot p' + (p^m)' \cdot p \end{aligned}$$

By definition of arithmetic derivative,

$$\begin{aligned} n' &= p^m + mp^m \\ n' &= (m + 1)p^m. \end{aligned}$$

Thus, the statement is true for all positive integral values of k .

1.2. (General Product Rule). If $n = p_1 p_2 p_3 \dots p_k$, then $n' = n \sum_{i=1}^k \frac{1}{p_i}$ for any primes p_i .

Proof:

Let n be a natural number such that $n = \prod_{i=1}^k p_i$ for all primes p . We will claim that for $i = 1$, $n' = 1$ by definition of arithmetic derivative. For $i = 2$, such that $n = p_1 p_2$ then we have $n' = p_1 + p_2$. Suppose that it is true for $i=j$ such that if $n = \prod_{i=1}^j p_i$, $n' = n \sum_{i=1}^j \frac{1}{p_i}$. Since $k = j$, we will show that it is also true for $k = j + 1$ such that $n = \prod_{i=1}^{j+1} p_i$ it follows that

$$\begin{aligned} n' &= [(\prod_{i=1}^j p_i)(p_{j+1})]' = (\prod_{i=1}^j p_i)'(p_{j+1}) + (\prod_{i=1}^j p_i) \text{ that is} \\ n' &= \left[n \sum_{i=1}^j \frac{1}{p_i} \right] p_{j+1} + \prod_{i=1}^j p_i \\ n' &= \prod_{i=1}^{j+1} p_i \left[\sum_{i=1}^j \frac{1}{p_i} + \frac{1}{p_{j+1}} \right] \\ n' &= \prod_{i=1}^{j+1} p_i \left(\sum_{i=1}^{j+1} \frac{1}{p_i} \right) \\ n' &= n \sum_{i=1}^{j+1} \frac{1}{p_i}, \text{ for } n = \prod_{i=1}^{j+1} p_i. \end{aligned}$$

Thus the theorem holds. ■

1.3. The derivative n' can be well-defined as follows: if $n = \prod_{i=1}^k p_i^{\alpha_i}$ is a factorization in prime powers, then

$$n' = n \sum_{i=1}^k \frac{\alpha_i}{p_i}.$$

Proof:

We will claim that for $k = 1, n' = \alpha_1 p_1^{\alpha_1 - 1}$ by definition of arithmetic derivative. By letting $k = 2$, we have $n = p_1^{\alpha_1} p_2^{\alpha_2}$ then

$$\begin{aligned} n' &= p_1^{\alpha_1} \cdot \alpha_2 p_2^{\alpha_2 - 1} + \alpha_1 p_1^{\alpha_1 - 1} p_2^{\alpha_2} \\ n' &= p_1^{\alpha_1} p_2^{\alpha_2} \left[\frac{\alpha_2}{p_2} + \frac{\alpha_1}{p_1} \right] \\ n' &= n \sum_{i=1}^2 \frac{\alpha_i}{p_i} \end{aligned}$$

Suppose that the theorem is true for $k = j$ such that $n = \prod_{i=1}^j p_i^{\alpha_i}$ and $n' = n \sum_{i=1}^j \frac{\alpha_i}{p_i}$. We will show that for the next integer $k = j + 1$ is also true such that

$$\begin{aligned} n' &= \left(\prod_{i=1}^j p_i^{\alpha_i} \right) p_{j+1}^{\alpha_{j+1}} \\ &= \prod_{i=1}^j p_i^{\alpha_i} \cdot \alpha_{j+1} p_{j+1}^{\alpha_{j+1} - 1} + \left(\prod_{i=1}^j p_i^{\alpha_i} \right)' p_{j+1}^{\alpha_{j+1}} \\ &= \left(\prod_{i=1}^{j+1} p_i^{\alpha_i} \right) \left(\frac{\alpha_{j+1}}{p_{j+1}} \right) + \left(n \sum_{i=1}^j \frac{\alpha_i}{p_i} \right) p_{j+1}^{\alpha_{j+1}} \\ &= n \left(\frac{\alpha_{j+1}}{p_{j+1}} + \sum_{i=1}^j \frac{\alpha_i}{p_i} \right) \\ n' &= n \sum_{i=1}^{j+1} \frac{\alpha_i}{p_i} \end{aligned}$$

Thus, the theorem holds. ■

1.4. For any natural $k > 1$,
 $n' \geq n \Rightarrow (kn)' > kn$.

Proof:

Let k, n be a natural number, $k > 1$ and $n' \geq n$ then
 $(kn)' = k'n + kn'$

$$k'n + kn' > kn' \geq kn,$$

Thus,

$$(kn)' > kn. \blacksquare$$

2. Arithmetic Derivative of Some Integer Sequences

2.1. For every even perfect number n ,

$$n' = 2^{k-2}(kp - p + 2).$$

Proof:

Let n be even perfect number such that $n = 2^{k-1}(2^k - 1)$ using definition of perfect number. Then

$$n' = [2^{k-1}(2^k - 1)]'$$

Then by 1.1. gives,

$$n' = 2^{k-1} + (2^k - 1)(k - 1)(2^{k-2})$$

Let $2^k - 1 = p$, then

$$n' = 2^{k-2}(2 + (k - 1)p)$$

That is

$$n' = 2^{k-2}(kp - p + 2). \blacksquare$$

2.2. For any square free number n , in the form of $p_1 p_2 p_3 \dots p_k$, $n' = n \sum_{i=1}^k \frac{1}{p_i}$.

Proof:

Let n be square free number in the form of $n = p_1 p_2 p_3 \dots p_k$. Using 1.1.,

$$n' = n \sum_{i=1}^k \frac{n_i}{p_i}$$

But since, n is square free,

Then

$$n'_i s = 1. \text{ Thus, } n' = n \sum_{i=1}^k \frac{1}{p_i}. \blacksquare$$

2.3. If n is square number in the form of $n = p_1^2 p_2^2 p_3^2 \dots p_k^2$ or $(p_1 p_2 p_3 \dots p_k)^2$,

$$n' = 2n \sum_{i=1}^k \frac{1}{p_i}$$

Proof:

Let n be a square number such that $n = (p_1 p_2 p_3 \dots p_k)^2$. Then,

$$n' = (p_1^2 p_2^2 p_3^2 \dots p_k^2)'$$

By 1.2., gives,

$$n' = n \left(\frac{2}{p_1} + \frac{2}{p_2} + \frac{2}{p_3} + \dots + \frac{2}{p_k} \right)$$

It follows that

$$n' = 2n \sum_{i=1}^k \frac{1}{p_i}. \blacksquare$$

CONCLUSION

Based on the findings, the following conclusions were drawn:

1. The Leibnitz rule of differentiation such as power rule, general product rule, and linearity were also derived.
2. Several properties were also derived using the definition of arithmetic derivative and different rules of differentiation.
3. Special properties of arithmetic derivative were established in perfect number, square free numbers, and square numbers.

REFERENCES

- Pentti Haukkanen, Jorma K. Merikoski and Timo Tossavainen (2018). The Arithmetic Derivative and Leibnitz – Additive Functions, Notes on Number Theory and Discrete Mathematics, Print ISSN 1310–5132, Online ISSN 2367–8275, Volume 24, 2018, Number 3, Pages 68–76, DOI: 10.7546/nntdm.2018.24.3.68-76.
- Mike Krebs, Caleb Emmons & Anthony Shaheen (2009). How to Differentiate an Integer Modulo n , The College Mathematics Journal, 40:5, 345, 353, DOI: 10.4169/074683409X475661.
- Stay, Michael (2005). Generalized Number Derivatives, The Journal of Integer Sequences , Volume 8 (2005), Article 05.1.4.
- V. Ufnarovski and B. Ahlander (2003). How to differentiate a number. Journal of Integer Sequences, Vol.6, Article 03.3.4, Sweden.
- E. J. Barbeau, Remark on an arithmetic derivative, Canadian Mathematics Bulletin 4 (1961), 117– 122.
- J. Renze, S. Wagon, and B. Wick, The Gaussian zoo, Experiment. Math. 10:2 (2001), 161–173.
- A. M. Gleason, R. E. Greenwood, and L. M. Kelly, The William Lowell (1980). Putnam Mathematical Competition: Problems and Solutions 1938–1964, Mathematical Association of America.

FACE SHIELD WITH BODY TEMPERATURE SCANNER AND RECORDING SYSTEM

Edgardo R. Sison

INTRODUCTION

This new respiratory virus called the Novel Coronavirus 2019 or COVID-19 is making news because it is creating a worldwide outbreak of respiratory disease. This virus started in Wuhan, Hubei Province, China, rapidly spread through Southeast Asia and worldwide. According to the World Health Organization, COVID-19 came from the virus caused by SARS-CoV-2, which passed on from person to person, primarily through close contact. The government is looking for various ways to defend and protect itself from this pandemic, looking to the most frequent symptoms of COVID-19 such as fever, dry cough, and fatigue. How will it improve the detection, tracking, and controlling the spread of this virus within the country?

This study aims to design and develop a face shield with a body temperature scanner and recording system using a system of identification that allows the user to instantly access information for tracking, collecting, and securing data that can use during this pandemic.

METHODOLOGY

The research used the developmental type of research, which is defined as in contrast to simple instructional development. Developmental research has been described as the systematic study of designing, creating, and evaluating instructional programs, processes, and products that must meet internal consistency and effectiveness criteria in the field of instructional technology.

The most popular forms of developmental research are those in which the product development process is studied and explained, and the final product is assessed.

EVALUATION METHOD

The research output was evaluated on the following criteria, namely: Functionality, Usability, Reliability, Efficiency, and Maintainability.

Criteria	Students	Professor	Community	Composite Mean	VI	Rank
1. Functionality	3.97	4.07	4.07	4.03	VS	2
2. Usability	4.35	4.05	3.90	4.10	E	1
3. Reliability	3.95	4.05	4.05	4.02	VS	3
4. Efficiency	4.00	4.03	3.77	3.93	VS	4
5. Maintainability	3.93	4.00	3.57	3.83	VS	5
Overall Composite	4.04	4.04	3.87	3.98	VS	

Table shows the result of the over – all assessment of the three groups of respondents, namely: Students, Professionals and Community. The over – all composite mean has a numerical value of 3.98 interpreted as “Very Satisfactory.

Rank 1 is "Usability" with a composite mean of 4.10 and interpreted as "Excellent."

Rank 2 is "Functionality" with a composite mean of 4.03 and interpreted as "Very Satisfactory."

Rank 3 is "Reliability" with a composite mean of 4.02 and interpreted as "Very Satisfactory."

Rank 4 is "Efficiency" with a composite mean of 3.93 and interpreted as "Very Satisfactory."

Rank 5 is "Maintainability" with a composite mean of 3.83 and interpreted as "Very Satisfactory."

RECOMMENDATIONS

1. This research recommend to used alternative light-weight materials in creating this project such as 3D print casing of the face-shield and acrylic since the weight of the prototype device can be uncomfortable to wear for a long period of time.

2. The researchers also recommend integrating display module for temperature display and for further develop

3. For further development, the researchers also recommend of integrating voice module to the QR Scanner which will indicate that the user is already done with the assessment.



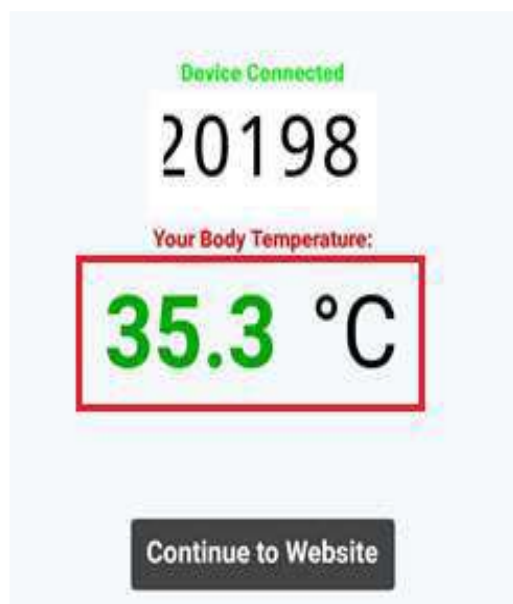

EARIST
COVID TRACER



- How to Connect to Bluetooth Device?
1. Open Bluetooth on your Device
 2. Turn On Bluetooth in Faceshield device
 3. Click "Tap to Connect"
 4. Connect to HC-05

PRIOR ART REPORT

SEARCH STRINGS AND DATABASES

Database	Search String	Number of Hits
1. wipo	Wearable AND Body Temperature AND Database	30,658
	"Body Temperature" AND Monitoring AND Wearable AND Tracking AND Bluetooth AND lot AND GPS	614
	"Body Temperature" AND Monitoring AND Wearable AND Tracking AND Bluetooth AND lot	740
2. espacenet	Wearable AND Body Temperature AND Database	8
	Wearable AND Body Temperature AND Monitoring AND Cloud AND Bluetooth	2

DOCUMENTS CONSIDERED TO BE RELEVANT

Category	Document Information			Relevant to Claim No.
	Patent No.	Title	Publication Date	
1. Y	20160256055	Body surface thermometer and wearable temperature measuring device	02/05/2019	Claim 1
2. Y	206410795	Wearable thermometers	08/15/2017	Claim 1
3. Y	111366248 (A)	Self-service Bluetooth forehead temperature gun	07/03/2020	Claim 2
4. Y	IN202041043957	An intelligent system for covid-19 precautions using IOT	10/16/2020	Claim 7

REFERENCES

- David H. Slade, M. J. (202, September 23). *Journal List: Return to work during coronavirus disease 2019 (COVID-19): Temperature screening is no panacea*. Retrieved from National Center for Biotechnology Information: <https://www.ncbi.nlm.nih.gov/pmc/articles/PMC7542314/>
- Gita-Carlos, R. A. (2020, July 31). Articles: Use of face shields in public spaces encouraged. Retrieved from Philippine News Agency: <https://www.pna.gov.ph/articles/1110767>
- Gürhan Durak, E. E. (2016, April). Publication: QR codes in education and communication. Retrieved from Research Gate: https://www.researchgate.net/publication/300081637_QR_codes_in_education_and_communication



Behavioral Research

EFFECTS OF TEXT MESSAGING ON THE SPELLING AND VOCABULARY SKILLS OF SELECTED FRESHMEN STUDENTS: BASIS FOR SCAFFOLDING ACTIVITIES FOR SOCIAL SCIENCE ACADEMIC WRITING

Arnold O. Adante

INTRODUCTION

Technology became the result of man's immeasurable desire to make the quality of life or living easier. Experimentations and inventions paved the way for the proliferation of different technological and modern gadgets. Now, each and every walk of life from the very complex aspects of living down to the simplest has a touch of technology. The impact of technology on many things, like the use of English cannot be ignored. Instructors make use of power point presentation in the classrooms; students resort to Internet when they research on assigned topics, when they communicate with friends outside of the school, or in other countries. And in those situations, the use of English is inevitable. Unfortunately, not all students are good at English grammar, especially spelling and vocabulary. It becomes worse when they learn to convey messages through texting; it introduces the use of incorrect grammar or spelling in the messaging "lingo". Standard spelling conventions and grammar rules are often disregarded and the use of "textisms" is prevalent.

STATEMENT OF THE PROBLEM

The researcher determined the effect of text messaging on the spelling proficiency and vocabulary skills of Freshmen Students of EARIST last academic year 2020-2021. This study also sought answers to the following questions:

1. What is the demographic profile of the selected freshmen of EARIST as to:
 - 1.1 age;
 - 1.2 gender;
 - 1.3 socio-economic status of parents
 - 1.4 highest educational attainment of parents; and
 - 1.5 frequency in using SMS style in keeping notes, and in assignment?
2. What types of textisms are frequently used by the selected students in text messaging?
3. What is the level of spelling proficiency and vocabulary skills of the selected students?
4. Is there a significant relationship between the students' textisms and their spelling and vocabulary skills?
5. What activities may be proposed to help students enrich their spelling and vocabulary skills to meet the requirements of Social Science academic writing activities?

MATERIALS AND METHODS

The researcher used the descriptive method to gather data on the existing condition of the subject of the study. Simple random sampling technique was used in the form of structured survey to gather information about their spelling skills in relation to spelling performance among selected college students. The researcher utilized the following statistical tools/formula: Mean Distribution, Frequency and Percentage Distribution of Data, Standard Deviation, Coefficient of Variation, and Regression Analysis.

RESULTS AND DISCUSSION

The following were the result on the research problem regarding the effects of text messaging on the spelling and vocabulary skills of selected freshmen students:

Table 1
Age Distribution of the Student-Respondents

Age	Frequency	Percentage
21 years	1	1%
20 years	5	5%
19 years	34	32%
18 years	65	62%
Total	105	100%

Mean Age = 18.45 years

Table 1 shows the age distribution of the student-respondents. Majority of the participants belong to the age of 18, which stand at 62%. Of the 105 selected freshmen students of EARIST who participated in the study, there were 34 student-respondents or 32% whose age is 19 while there were only 5 students or 5% of the respondents who are 20 years old. The remaining 1 student-respondent or 1% was 21 years old.

Table 2
Respondents' Gender Profile

Gender	Frequency	Percentage
Male	49	47%
Female	56	53%
Total	105	100%

Data in Table 2 show that out of 105 student-respondents who participated in the study, 49 or 47% were males while 56, or 53% were females. Male and female participants have participated in a slightly close to equal ratio which differs only by 6%, which implies that a slightly higher number of females participated in the survey than males. This could mean that there are more females who are fond of using phones or of sending messages to their friends. This could also indicate that they feel like expressing their thoughts or unleashing their feelings to people close to them.

Table 3
Socio-Economic Status of Parents in Terms of Monthly Income

Combined Monthly Income	Frequency	Percentage
P 50,000 – P 59,999	2	2%
P 40,000 – P 49,999	3	3%
P 30,000 – P 39,999	40	38%
P 20,000 – P 29,999	21	20%
P 10,000 – P 19,999	38	36%
Below P 10,000	1	1%
Total	105	100%
Mean Monthly Income = P 26,142.36		

On the average, as can be seen in Table 3, the respondents' socio-economic status of the family in terms of parents' combined monthly income is P26, 142.36 wherein 40 student-respondents or 38% of them have parents whose combined monthly income ranges from P30,000 – P39,999; 38 or 36% of the student-respondents, P10,000 – P19,999; twenty-one (21) or 20%, P20,000 – 29,999; 3 or 3% of the respondents, P40,000-P49,999; 2 or 2%, P50,000-P59,999; and 1 or 1% has parents or guardians with a monthly income below P10,000.

Table 4
Highest Educational Attainment of Parents

Educational Attainment	Father		Mother	
	F	%	F	%
Master's Degree	1	1%	1	1%
College Degree	55	52%	48	46%
Technical/Vocational Course	7	7%	4	4%
High School Graduate	36	34%	46	44%
Elementary Graduate	6	6%	6	6%
Total	105	100%	105	100%

Table 4 presents the educational attainment of the respondents' parents. Fifty-five (55) of the respondents of 52% of the group who participated in the study have fathers who are college degree holders; 36 or 34% of the group have fathers who are high school graduates; 7%, finished technical/vocational course; 6%, finished elementary; and 1% has master's degree.

Moreover, out of 105 respondents, 48 of them have mothers or female guardians that are college degree holders; 46 or 44%, had finished high school; 6% finished elementary; and 1 or 1% has master's degree.

It is evident that majority of the respondents' parents are college degree holders. Hence, they can communicate with their children using English language. One could also infer from this finding that they are more used to constructing their messages in formal language, that is, without acronyms or slang expressions.

In Table 5 below shows a cross tabulation for the frequency of using SMS style in taking down notes is presented in this table. First in rank reveals that oftentimes respondents use more than 10 textisms/textese in texting/chatting in one day, with 3.63 mean score. This is followed by abbreviating words in writing notes with 3.30 mean score and clipping words in taking down notes (like proj. for project, etc.) that obtained a 3.28 mean score. Making his/her own shortened forms of words in writing got 3.08 mean score while using SMS style in posting status on social media accounts obtained a 2.74 mean score. The table also reveals that taking lecture notes gathered a mean score of 2.73 and using SMS style in assignments has 2.70. This is closely followed by using an incorrect form of expression in written communication with 2.69 mean score. Moreover, using numerical letters in words. (like w8 for wait) in shortening of words garnered a mean score of 2.66 while using the SMS style when they do not know the spelling of the words had 2.51 mean score.

As a result, the grand mean score is 2.93 with SO frequency which means that the respondents sometimes use SMS in taking down notes. While students use textisms, most of the time in simply chatting or posting status on social media accounts, they could also serve a purpose for them as they could be helpful in taking down notes and in doing their assignments. In other words, the use of textisms is a convenient way to carry out their tasks.

Table 5
Frequency of Using SMS Style in Taking Down Notes

Indicator	Frequency					Mean	Rank
	A (5)	O (4)	So (3)	Se (2)	N (1)		
1. I take lecture notes in SMS style.	7	18	40	20	20	2.73 So	6
2. I use SMS style in my assignments.	8	18	37	18	24	2.70 So	7
3. I clip words in taking down notes (like proj for project, etc.)	20	29	27	18	11	2.28 So	3
4. I used to abbreviate words writing notes.	17	31	32	16	9	3.30 So	2
5. I make my own shortened forms of words in writing.	21	21	26	19	18	3.08 So	4
6. For shortening of text, I use numerical letters in words. (like w8 for wait).	13	20	21	20	31	2.66 So	9
7. I use more than 10 textisms/textese in texting/chatting in one day.	33	22	32	14	4	3.63 O	1
8. I keep using an incorrect form of expression in written communication.	6	16	37	31	15	2.69 So	8
9. I only use the SMS style when I do not know the spelling of the words.	4	14	38	25	24	2.51 So	10
10. I use SMS style in posting status on my social media accounts.	13	15	33	20	24	2.74 So	5
Mean	14	20	32	20	18	2.93 So	

Table 6 exposes the respondents' use of acronym in typing text messages. It is revealed that the mean number of respondents is 70 or 67% of them really use acronyms in their chat/text messages. As a result, the standard deviation is 33.31 and the coefficient of variation is 47.59%.

It could be gleaned from the findings that most of the respondents use acronyms in chatting or texting. This could mean that the respondents find acronyms the easiest and the fastest way of conveying messages.

Table 6
Respondents' Use of Acronym in Typing Text Messages

Text Message	Acronym	Frequency	Percentage
1. For your information	FYI	101	96
2. Talk to you later	TTYL	55	52
3. Thank you	TY	82	78
4. Oh my gosh	OMG	100	95
5. Do it yourself	DIY	93	89
6. Be right back	BRB	88	84
7. Happy birthday to you	HBD	88	84
8. I love you	ILY	74	70
9. You live only once	YOLO	79	75
10. See you later	SYL	52	50
11. Sorry later reply	SLR	73	70
12. Outfit of the day	OOTD	98	93
Mean Number of Respondents		70	67%
Standard Deviation		33.31	
Coefficient of Variation		47.59%	

Table 7
Use of Orthographic Abbreviation/Contraction in Typing Text Messages

Text Message	Orthographic Abbreviation	Frequency	Percentage
1. For your information	for yor infrmion	5	5
2. Talk to you later	tlk to you ltr	6	6
3. Thank you	Thnks	25	24
4. Oh my gosh	Omygsh	13	12
5. Do it yourself	do it yrslf	7	7
6. Be right back	be rght bck	14	13
7. Happy birthday to you	Hapy Brthdy	10	10
8. I love you	I lov yu	12	11
9. You live only once	yu liv only once	7	7
10. See you later	see you ltr	15	14
11. Sorry late reply	sory lte rply	10	10
12. Outfit of the day	outft of the dy	2	2
Mean Number of Respondents		9	9%
Standard Deviation		6.73	
Coefficient of Variation		74.78%	

Table 7 indicates that the mean number of respondents in using orthographic abbreviation/contraction in typing chat/text messages is 9 or 9%. As a result, the standard deviation is 6.73 and the coefficient of variation is 74.78%.

The result of the data gathered shows that the respondents are not fond of using orthographic abbreviation, which means that they still prefer the correct way of expressing themselves in complete words, that is, without deleting letters.

Table 8
Respondents' Use of Accent Stylization in Typing Text Messages

Text Message	Accent Stylization	Frequency	Percentage
1. For your information	fo your infomeyshun	1	1
2. Talk to you later	tok to yah later	4	4
3. Thank you	Thankie	10	10
4. Oh my gosh	ow ma gosh	4	4
5. Do it yourself	do it yoself	6	6
6. Be right back	be ry bk	1	1
7. Happy birthday to you	Hepy Birdey to yah	7	7
8. I love you	Alavyah	3	3
9. You live only once	you livonly once	1	1
10. See you later	see yah leytaaah	14	3
11. Sorry later reply	sowie late reply	15	14
12. Outfit of the day	outfit ovda day	2	2
Mean Number of Respondents		5	5%
Standard Deviation		4.99	99.80%

As shown in Table 8, the mean number of respondents in the use of accent stylization in typing text messages is 5 or 5%, the standard deviation is 4.99, and the coefficient of variation is 99.80%. Like the orthographic abbreviation, the use of accent stylization does not seem to be popular among the respondents. This could be attributed to their lack of familiarity with it, or to their desire to avoid misinterpretation.

Table 9 displays the result on the respondents' use of repeating letters to mirror lengthening in typing text messages which has 20 mean number of respondents or 19%; standard deviation of 14.28, and the coefficient of variation of 71.40%.

This could point to the idea that the respondents who use repeating letters in their texts find them a way of either emphasizing their messages or demonstrating an intention to make the recipients enjoy reading what is sent to them.

Table 9
Use of Repeating Letters to Mirror Lengthening in Typing Text Messages

Text Message	Repeating Letters	Frequency	Percentage
1. For your information	for youuur informatiooon	5	5
2. Talk to you later	talk to youuuu laterrrr	35	33
3. Thank you	Thank Yooooouuuuuu	31	30
4. Oh my gosh	ohhh my gosssh	19	18
5. Do it yourself	dooo ittt yoooursellfff	13	12
6. Be right back	bee riiight baaack	10	10
7. Happy birthday to you	Haaappyyy Birthdaaay to youuu	43	41
8. I love you	I loooveeee yoouuuu	37	35
9. You live only once	yoouu liiive onlyyy onnnce	14	13
10. See you later	see youuu laterrrr	35	33
11. Sorry late reply	sorrriyyy late replyyy	22	21
12. Outfit of the day	outfiit of the daaaay	13	12
Mean Number of Respondents		20	19%
Standard Deviation		14.28	
Coefficient of Variation		71.40%	

Table 10
Excessive Use of Capitalization in Typing Text Messages

Text Message	Excessive Capitalization	Frequency	Percentage
1. For your information	fOr yOu iNfOrmatiOn	2	2
2. Talk to you later	talk tO yOu Later	7	7
3. Thank you	ThAnk YoOOU	6	6
4. Oh my gosh	oH my gOsh	4	4
5. Do it yourself	Do iT yOuSelF	6	6
6. Be right back	bE right bAck	12	11
7. Happy birthday to you	HaPPy BirthdAy	8	8
8. I love you	I LOVe yOU	12	11
9. You live only once	yOu live oNly Once	9	9
10. See you later	sEE yOu later	12	11
11. Sorry late reply	sOrRy LatE rEpLy	8	8
12. Outfit of the day	oUtfit Of thE dAy	9	9
Mean Number of Respondents		7	7%
Standard Deviation		4.10	
Coefficient of Variation		58.57%	

Synthesized in Table 10 is the result of the respondents' excessive use of capitalization in typing text messages, and it showed that the mean number of respondents is 7 or 7% with standard deviation of 4.10 and 58.57% coefficient of variation.

This finding demonstrates the idea that most of the respondents do not prefer to use excessive capitalization as they probably know that it would give an interpretation which is not acceptable to the recipients/readers.

Table 11
Use of Excessive Use of Punctuation in Typing Text Messages

Text Message	Excessive Punctuation	Frequency	Percentage
1. For your information	for your !nformat!on,,,	0	0
2. Talk to you later	talk to you later...!!!!	21	20
3. Thank you	Thank You!!!!	0	0
4. Oh my gosh	oh my gosh!!!!!!!!!!!!	12	11
5. Do it yourself	do !t yourself,,,!!!	3	3
6. Be right back	be r!ght back!	3	3
7. Happy birthday to you	Happy B!rthday....,!!!	9	9
8. I love you	! love you!	9	9
9. You live only once	you !ve only once!!!...	3	3
10. See you later	see you later,,,!	17	16
11. Sorry late reply	sor! late reply,,,	1	1
12. Outfit of the day	outf!t of the day!!!	3	3
Mean Number of Respondents		6	6%
Standard Deviation		6.82	
Coefficient of Variation		113.67%	

Table 11 provides the result of the respondents' excessive use of punctuation in typing text messages with a 6-mean number of respondents or 6%, the standard deviation of 6.82%, and the coefficient of variation of 113.67%. This suggests that most of the respondents are not fond of using excessive use of punctuation marks as they might also generate an interpretation different from what they want to convey.

Table 12
Use of Phonological Abbreviation in Typing Text Messages

Text Message	Phonological Abbreviation	Frequency	Percentage
1. For your information	for your nformation	1	1
2. Talk to you later	tok to yu ltr	4	4
3. Thank you	Thanx	6	6
4. Oh my gosh	omy gosh	3	3
5. Do it yourself	do it urself	27	26
6. Be right back	be rye bak	7	7
7. Happy birthday to you	Hapy Brthdy	8	8
8. I love you	I lavyu	17	16
9. You live only once	yuliv only once	5	5
10. See you later	siyu latr	0	0
11. Sorry late reply	sory late reply	13	12
12. Outfit of the day	outfit ov d day	1	1
Mean Number of Respondents		7	7%
Standard Deviation		7.76	
Coefficient of Variation		110.86%	

The result of the respondents' use of phonological abbreviation in typing text messages is shown in Table 12. It reveals that the mean number of respondents is 7 or 7%; the standard deviation is 7.76, and the coefficient of variation is 110.86%. Like the accent stylization,

excessive use of capitalization and punctuation marks, the use of phonological abbreviation does not appear to attract the respondents as they probably prefer producing the correct sounds.

Table 13
Use of Letter/Number Homophone in Typing Text Messages

Text Message	Letter/Number Homophone	Frequency	Percentage
1. For your information	4 ur in4mation	4	4
2. Talk to you later	talk 2 u l8r	20	19
3. Thank you	Thank u	52	50
4. Oh my gosh	o my gosh	8	8
5. Do it yourself	do 8 urself	5	5
6. Be right back	b ryt back	4	4
7. Happy birthday to you	Ha P Birthday 2 u	7	7
8. I love you	I love u	56	53
9. You live only once	u live only 1s	10	10
10. See you later	c u l8r	18	17
11. Sorry late reply	sorry l8 reply	9	9
12. Outfit of the day	outfit of d day	6	6
Mean Number of Respondents		14	13%
Standard Deviation		17.81	
Coefficient of Variation		127.21%	

Obtained in Table 13 is the result of respondents' use of letter/number homophone in typing text messages. It discloses that the mean number of respondents is 14 or 13%.; the standard deviation is 17.81, and the coefficient of variation is 127.21%.

Table 14
Summary Data on the Respondents' Types of Textism Frequently Used in Text Messaging

Type of Textism	Mean		SD	CV	Rank
	F	%			
Acronym	70	67	33.31	47.59	1
Orthographic Abbreviation/ Contraction	9	9	6.73	74.78	4
Accent Stylization	5	5	4.99	99.80	8
Repeating Letters to Mirror					
Lengthening	20	19	14.28	71.40	2
Excessive Use of Capitalization	7	6	4.10	58.57	5.5
Excessive Use of Punctuation	6	6	6.82	113.67	7
Phonological Abbreviation	7	6	7.76	110.86	5.5
Letter/Number Homophone	14	13	17.81	127.21	3
Mean Number of Respondents: f = 17 or 16%					

Respondents use different types of textisms as seen in Table 14 which provides a summary data on the respondents' types of textisms frequently used in text messaging. The above tabular data show that, on average, 17 of the 105 respondents would use each textism when sending text messages; use of acronym, 70 or 67%; and use of accent stylization, 5%.

There are variation coefficients in the data that exceeded 100% as the standard deviation exceeded the corresponding mean. This indicates that use of the type of textism varies greatly among text messages. In certain text messages, it is used, in others it is not. Thus, use of textism type is not consistent.

Table 15
Level of Student-Respondents' Proficiency in Spelling and Vocabulary

Raw Score	Score Transmutation	Spelling Frequency	Percentage	Vocabulary Frequency	Percentage
20	100	5	5	1	1
19	98	8	8	1	1
18	95	21	20	4	4
17	93	17	16	17	16
16	90	17	16	28	27
15	88	11	10	23	22
14	85	7	7	12	11
13	83	7	7	8	8
12	80	12	11	11	10
20	100	5	5	1	1
19	98	8	8	1	1
18	95	21	20	4	4
Total		105	100%	105	100%
Mean Score		RS = 16.09 or 90%		RS = 15.21 or 88%	
Standard Deviation		2.29		1.73	
Coefficient of Variation		14.23%		11.37%	

RS: Raw Score

Table 15 presents the result of the student-respondents' level of spelling and vocabulary. In the twenty-item spelling test of the 105 respondents, 21 of them got 18 points; 17, 17 points; 17, 16 points; 12, 12 points; 11, 15 points; 8, 19 points; 7, 14 points; 7, 13 points; and 5 got the perfect score of 20 points.

Meanwhile, in the twenty-item vocabulary test, out of 105 respondents, 28 of them achieved 16 points, 23, 15 points; 17, 17 points; 12, 14 points; 11, 12 points; 8, 13 points; 4, 18 points; 1 got 19 points; and 1 achieved the perfect score of 20.

The respondents' level of proficiency is expanding as seen in the mean scores on spelling and vocabulary tests, which are 16.09 or 90% and 15.21 or 88% respectively. The standard deviation obtained from the spelling test is 2.29 and 1.73 from the vocabulary test. Spelling test got the coefficient of variation of 14.23% and 11.73%, from vocabulary test.

Based on the result of the respondents' mean scores of 16.09 or 90% on spelling and 15.21 or 88% on vocabulary, the students' level of proficiency is expanding, that is, the students have an extensive understanding of English words.

Table 16 provides the result of significance between students' textisms and their spelling proficiency, and it was found to be not significant. As exhibited in the table below, the computed value of -0.20 did not exceed the tabular value of 1.98 in the overall use of textisms with level of significance at 0.05 and 103 degrees of freedom.

These findings imply that learners' exposure to correctly spelled words at an early age benefits spelling. In other words, when children are given more opportunities to read books even at pre-school age, the greater the likelihood that they will reproduce spellings of words they have seen and heard. And when children repeatedly practice and use them, they begin to store the correctly spelled words in their long-term memory. That means that even when they use textisms, they still know how to use the correct words when asked in a test or in any spelling activity.

Table 16
Relationship between the Students' Textisms Used in
Text Messaging and their Spelling Proficiency

Types of Textism	B	t – Value		Interpretation/ Ho Decision
		Comp	Tabular	
Acronym	-0.07	-0.74	1.98	Not Significant/Accept
Orthographic Abbreviation/ Contraction	-0.17	-1.13	1.98	Not Significant/Accept
Accent Stylization	-0.21	-0.92	1.98	Not Significant/Accept
Repeating Letters to Mirror Lengthening	0.06	0.76	1.98	Not Significant/Accept
Excessive Use of Capitalization	0.05	0.36	1.98	Not Significant/Accept
Excessing Use of Punctuation	0.02	0.11	1.98	Not Significant/Accept
Phonological Abbreviation	-0.06	-0.33	1.98	Not Significant/Accept
Letter/Number Homophone	-0.06	-0.40	1.98	Not Significant/Accept
Overall Use of Textism	-0.06	-0.20	1.98	Not Significant/Accept
Degrees of Freedom = 103		Level of Significance = 0.05		

Comp: Computed; Tab: Tabular

Meanwhile, as revealed in table 17, the relationship between the students' textisms and their vocabulary skills was found to be not significant as well. Presented in the table below, the computed value of -0.59 did not exceed the tabular value of 1.98 in the overall use of textisms with level of significance at 0.05 and 103 degrees of freedom.

Reading traditional print media or books exposes students to words not found in the colloquial peer-to-peer text messaging used among youth or 'generation text'. Hence, this indicates that if students have developed the habit of reading books, they get used to the more formal words, they understand them, and use them frequently in conversation or discussion, that no amount of colloquial expressions or even slang words will affect their vocabulary skills adversely.

Moreover, the quality of parent-child interactions influences children's vocabulary. If parents often engage them in a conversation using English words, they hear from eloquent speakers in TV programs, or English movies, they equip the students with a variety of correct words with their meanings. This redounds to the failure of textisms to hurt the vocabulary skills of students.

Table 17
Relationship between the Students' Textisms Used in
Text Messaging and their Vocabulary Proficiency

Types of Textism	B	t – Value		Interpretation/ Ho Decision
		Comp	Tabular	
Acronym	0.04	0.50	1.98	Not Significant/Accept
Orthographic Abbreviation/ Contraction	-0.12	-1.03	1.98	Not Significant/Accept
Accent Stylization	-0.19	-1.07	1.98	Not Significant/Accept
Repeating Letters to Mirror Lengthening	-0.02	-0.36	1.98	Not Significant/Accept
Excessive Use of Capitalization	-0.03	-0.23	1.98	Not Significant/Accept
Excessing Use of Punctuation	0.04	0.29	1.98	Not Significant/Accept
Phonological Abbreviation	0.04	.028	1.98	Not Significant/Accept
Letter/Number Homophone	-0.12	-1.02	1.98	Not Significant/Accept
Overall Use of Textism	-0.13	-0.59	1.98	Not Significant/Accept
Degrees of Freedom = 103	Level of Significance = 0.05			

Comp: Computed; Tab: Tabular

The two tabular data above disclose that there is no significant relationship between the respondents' textism and their vocabulary and spelling skills. The results of the test show that texting does not greatly influence the spelling and vocabulary proficiencies of the selected freshmen of EARIST.

Proposed Scaffolding Activities for Social Science Academic Writing

Scaffolding helps the teacher to assist students in transitioning from supported to independent tasks. It is a step-by-step process that offers ample feedback to the learner before the process is mastered, and then progressively eliminates the support in order to pass responsibility for the task completion to the student. Scaffolding is one process that allows teachers to organize a writing activity systematically to meet the needs of all students.

To help students comply with the requirements of academic writing, like a formal essay, a research paper, and a book review, it is important that the students know what academic writing and its features. To begin with, academic writing is just like the formal writing style, using the right structure for language along with a clear writing style. Some of its features are as follows: Sentence style is formal. The writer avoids slang, informal idioms, and nonstandard usages; overall tone is objective, avoiding most, if not all, first-person references; and subject matter addresses an issue of concern.

Some scaffolding activities may help students' ability to come close to the feature of an academic writing or a formal writing.

1. Make the students differentiate formal from informal language. One nice game for this is giving each student one card with "Formal" on it and another with "Informal" on it. They listen to phrases the teacher reads out like "Wassup?" and "I hope this email finds you well" and hold up the cards to indicate what they think about the formality they hear. They can then label the same phrases on a worksheet and try to draw up rules for formal and informal language from those examples.

2. Introduce common mistakes, giving students cards that say "Informal" and "Wrong" to hold up when they hear "Looking forward to hearing from you" and "I look forward to hear from you".

3. Give students mixed up formal and informal conversations or emails to sort out.

This can be a formal exchange and an informal one to divide from each other and then put into order, or an email exchange (that gets more and more informal as it goes on).

4. Give them phrases or emails and their responses (e.g. "Hiya. How's it going?" "Great. You?") that they should match up from formality and meaning clues.

5. Engage students in a memory game. Give them a set of about fifteen to twenty cards that have a formal sentence on one side and an informal version of the same thing on the other (e.g. "Dear Mr. Smith" and "Hi John"). Students lay them in vertical line on the table in front of them, representing the ladder that they must climb. It does not matter which side is showing. They climb the ladder by guessing/remembering the exact wording of the other side of every card, moving all the way from the bottom to the top. Any mistakes mean play passes to the next person, and all players must start at the very bottom each and every time. Cards remain turned over if they guess correctly, meaning the next person must change the formality the other way round.

6. Get students correct formality mistakes. This works best if the formality problems are mixed up with spelling mistakes, and paragraphing problems. Give them a conversation or email exchange with a mix of such problems to sort out or give them a succession of tasks that just have a single kind of problem that they should identify and then correct. For example, the first email and response you give them has 15 spelling mistakes; then once they have found and corrected all of them, give a similar worksheet with 15 formality problems on it.

7. Give students very informal sentences that they should compete to make more and more formal. Example is "Pass me the salt, will you?" and "Could you possibly pass me the salt for just a moment or two if it's not too much trouble?" and beyond. When they give up or the last sentence was actually less formal than the previous one, the last person gets a point, and they do the same thing with a different sentence.

CONCLUSION/ RECOMMENDATION

Conclusion

On the account of the foregoing findings, the following conclusions were drawn:

1. Parents' educational attainment and combined monthly income have a great effect on the students' language development.
2. Most of the respondents use acronyms in chatting or texting. This could mean that the respondents find acronyms the easiest and the fastest way of conveying messages.
3. Students, whose parents have high educational attainment, acquire from them enough knowledge and experience in English language, as they engage in a conversation with them in English, aside from watching English movies often. In addition, high school students have already spent a lot of time learning English language with their teachers and classmates, having been at school for a number of years. All these may have contributed to their proficiency in both spelling and vocabulary, which are expanding.
4. Textisms will not have a negative effect on the spelling and vocabulary performance of students who have better knowledge of English. With such competence, usage of the language becomes automatic that speaking it appears to be second nature to them. Hence, as the British press (Fresco, 2005) says, "Fears that text messaging may have ruined the ability of teenagers to write properly have been shown to be unfounded."
5. Scaffolding activities may help students comply with the requirements of the subject, particularly tasks on academic writing such as formal essay, book review, or research paper.

Recommendations

The following recommendations are given based on the results of the study and conclusions drawn:

1. School administrators should assign a writing center for students. It would provide opportunities for students to write more or organize a writing club which will encourage the students to practice writing on topics that will enhance their ability to produce academic writing, which will augment their list of formal expressions or develop a good command of academic vocabulary.
2. Module Writers should enrich the content with exercises or activities on writing. These may be in the form of reflection, an informative text, or an argumentative text. They should also ensure that models are given, to broaden the students' vocabulary.
3. Teachers should show good examples of formal writing and should devise a strategy or an approach that would develop the students' interest in writing. It could be a process approach. A focus on process allows students to better understand how they write, makes them better at critiquing their own and others' writing, and reinforces an awareness of audience. This process involves students in brainstorming, diagramming, outlining, combined with peer and teacher commentary.
4. Students should look at writing as a challenge and in their college life which would require them to do different kinds of academic writing which they will find very helpful in achieving a successful professional life.
5. Parents should inculcate in their children the importance of developing the skill in writing, particularly on academic topics as this task would equip them with much information which they would use in their everyday life.

ONLINE RESOURCES/WEBSITE

Aquino, G. (2015) Definition of Descriptive Method. Retrieved from: <https://www.coursehero.com/file/7233733/Descriptive-research/>

De Guzman, Donald C. (2014) Text Messaging Implication to Education. Retrieved from: https://www.pressreader.com/philippines/sunstarpampanga/20140619/28159_953357

PAGBUO NG GENDER NEUTRAL GUIDELINES SA PAGGAMIT NG WIKANG FILIPINO SA DIGITAL NA TALASTASAN

Joseph C. Anggot

INTRODUKSYON

Ang sexist na wika ay isang wika na nagpapahayag nang pagiging bias o pagkiling sa isang kasarian, na siyang magiging daan upang magkaroon ng banta ng deskriminasyon sa ibang kasarian. Sa mga pagkakataon, ang pagkiling ay nasa lalake. (Lei, 2006, p. 87).

Maraming mga linggwista ang nagsasabi na ang wikang Filipino ay isang non-sexist na wika. Isa sa nakikitang kadahilan nito ay ang pagiging non-sexist ng mga pangngalan (noun) nito. Hal: asawa, kasintahan, pinsan, anak, mamamayan, magulang atbp. Kakikitaan din nang pagiging non-sexist ang mga panghalip nito. Hal naman nito ay siya, sila, kami, tayo, si/sina atbp.

Ang kaisipang ito ang nais buwagin ng mananaliksik. Paniwala niya, ang wikang Filipino ay kakikitaan din ng pagiging sexist. Upang patunayan ito, ang mananaliksik ay nagsagawa ng isang pag-aaral na magpapatunay sa pagiging sexist ng wikang ito. Ginamit ng mga mananaliksik ang UP Diksyunaryo, Binagong Edisyon 2010 sa paghanap ng mga salitang siyang magpapatunay sa pagiging sexist nito. Ginamit naman ng mananaliksik ang teoryang Socialist Femenism upang taluntunin ang ugat ng pag-usbong ng mga salitang sexist na maitatala.

MGA LAYUNIN

Sa ginawang pag-aaral na ito, nilayon ng mananaliksik na...

1. Matukoy ang mga sexist na salita sa wikang Filipino;
2. Mailarawan ang kasaysayan ng seksismo ng mga Filipino salitang maitala; at
3. Makagawa ng isang guidelines na makatutulong sa non-sexist na paggamit sa wikang Filipino.

KAHALAGAHAN NG PAG-AARAL

Para sa mga mag-aaral

Ang pag-aaral na ito ay makatutulong upang maisulong ang "Gender Neutrality" na kaisipan sa mga mag-aaral ng Kolehiyo ng Eulogio Amang Rodriguez Institute of Science and Technology. Ninanais ng pag-aaral na ito na matulungan ang nasabing mag-aaral na maging gender sensitive sa paggamit ng wikang Filipino sa digital na talastasan.

Para sa mga guro

Ang guidelines na ginawa ng mananaliksik ay maaaring gamitin ng mga guro ng Kolehiyo ng Eulogio Amang Rodriguez Institute of Science and Technology bilang lunsaran sa

pagtuturo sa kanilang mga mag-aaral kung paano gagawing non-sexist ang mga sexist na salita sa wikang Filipino.

METODOLOHIYA

Ang mananaliksik ay gumamit ng historikal na palarawang disenyo sa pananaliksik na naglalayong isalarawan ang seksismong nagaganap sa bansa. Sa tulong ng sexist feminism theory, tinukoy ang mga sexist na salita sa Filipino na siyang maglalarawan nito. Inihanay ng mga mananaliksik ang naitalang sexist na salita sa pamamagitan ng isang talahanayan batay sa mga sumusunod na detalye:

1. Sexist ng mga Salita sa Filipino
2. Kahulugan ng mga Sexist na Salita
3. Katumbas na Gender Neutral na Salita sa Filipino

DISKUSYON

Simula pa lamang na likhain ng Diyos ang tao, ang babae ay nakaranas na ng opresyon. Ayon nga sa Genesis 3:18, “Babae, daragdagan ko ang iyong paghihirap sa pagdadalantao, at manganganak ka sa sakit. Kakailanganin mo ang iyong asawa, at ikaw ay magpapasakop sa kanya.”

Ang ganitong isteryotyping na sitwasyong kinasadlakan ng babae ay nagpasalin-salin sa maraming henerasyon. Ngunit noong sumapit ang taong 1970’s, sumibol ang Socialist Feminism, isang sangay na Feminismo na naglalayong buwagin ang konseptong ito.

Ang Socialist Feminism ay isang teorya na naglalayong ipabatid na ang kapitalismo at patriyarkal na sistema ng lipunan ang siyang pangunahing dahilan sa nararanasang opresyon ng kababaihan. Binigyang pansin din sa teoryang ito ang gamapaning papel ng kasarian at kolonyalismo bilang daan sa nasabing opresyon.

Kaugnay nito, ang pang-aabuso o opresyon sa kababaihan ay makikita rin sa wikang sinasalita niya sa lipunang kanyang ginagalawan. Karamihan sa mga ito ay sexist na kung saan nagbibigay pagkiling sa lalake at nagiging daan naman ng deskriminasyon sa babae.

Sa puntong ito, sinuri ng mananaliksik ang opresyon na nararanasan ng babae sa ating lipunan sa pamamagitan ng pagtala ng mga sexist na salita. Ginamit ang lenteng Socialist Feminism upang taluntunin ang kasaysayan ng pagsibol ng mga salita nito nang sa gayon maugat kung saang yugto ng panahon umusbong ang pagiging sexist ng ating lipunan at opresyong nararanasan ng mga kababaihan.

MAYBAHAY vs KATUWANG SA BUHAY

Ang wika at kultura ay magkakaugnay. Kaya ang pagiging sexist ng isang wika ay mauugat sa uri ng kultura mayroon ang nagsasalita nito.

Kaugnay nito, sinasabi na hindi likas sa ating wika ang pagiging sexist. Ito’y sa kadahilanang egalitarian ang uri ng lipunang ginagalawan noon ng ating mga ninuno.

Nangangahulugan ito na hindi lamang ang lalake ang may karapatang tinatamasa, mayroon din ang mga babae.

Ayon kay Alzona (1934), ang mga babae noong panahon ng katutubo ay trinatrato na kapantay ng kabiyak nito; napapanatili nito ang kanyang apelyido sa pagkadalaga; kinokonsulta ng kanyang asawa hinggil sa mga usaping kalakalan o negosyo; at maaaring hiwalayan ang kanyang asawa kung hindi siya nito trinatrato nang maayos o dili kaya sinusupportahan sa kanyang mga pangangailangan.

Ang mga babae sa panahon ng katutubo ay itinuturing na katuwang sa buhay ng mga lalake, hindi lamang sa loob ng pamamahay kundi maski sa lipunang ginagalawan niya. Ang babae ay maaaring maging chieftain (pinuno) ng isang balangay at gumaganap bilang babaylan. (Feliciano, 1996)

Ngunit nang dumating ang mga Kastila, ang gampanin ng babae ay natali sa pagiging maybahay. Nangangahulugan na ang gampaning papel lamang ng babae ay magmay-ari ng bahay (kasama na rito ang pangangalaga at paglilinis nito) habang hindi pa dumarating ang kanyang asawa. (Santos, 1991).

Ang ganitong sitwasyon na kinasadlakan ng babae ay resulta nang pagpapatupad ng Kastila ng sistemang patriyarkal sa lipunan. Naging mababa ang pagtingin sa kakayahan ng babae. Tinuring silang mahinang indibidwal dahilan ipagkatiwala lamang sa kanila ang mga gawaing nauukol sa tahanan. Ilan sa mga ito ay ang yaya at mutsatsa na naisteryotayp na trabaho ng isang babae at ni walang katumbas na salita sa lalakeng perspektibo.

PUTA VS BIRHEN

Ang pagkakakilanlan ng kababaihan sa kasalukuyan ay mauugat sa ginawang depinasyon ng Simbahang Katoliko (patriyarkal na relihiyong institusyon) sa konsepto ng pagiging babae.

Ang mga prayleng Kastila ay binigyan ang mga Filipina ng dalawang hulmahan ng kanilang pagkakakilanlan bilang babae: ang birheng martir at mapag-arulang ina na si Maria at ang masama at bayarang babae na si Magdalena. (Anonuevo, 2008).

Kaugnay sa bagay na ito, puta ang katawagang ikinakabit sa mga babaeng maituturing na Magdalena. Ilan pa sa mga mapag-aglahing salita na maikakabit sa babae ay makikita sa ibaba:

Sexist na Salita	Kahulugan
Disgrasyada	Babaeng hindi pinanagutan nang nakabuntis sa kanya
Kerida	Kabit

Ang mga salitang Kastila na ito ay naging bahagi na ng leksikon (talaan ng mga salita) ng wikang Filipino. Mapapansin sa wikang ito ang paggamit ng mga hulaping /a/ (kapag babae) at /o/ (kapag lalake) upang ipakita ang kasarian ng isang indibidwal.

Kung pakasusuriin ang mga salitang nabanggit sa itaas, mapapansin na wala itong katumbas na salita sa lalakeng perspektibo. Kung papalitan naman ang hulapi ng mga salitang ito ng /o/, magiging iba ang kahulugan nito. Hal: ang puta ay maaring maging puto na nangangahulugan isang uri ng kakanin, ang disgrasyada naman ay magiging disgrasyado na

ang ibig sabihin ay isang lalakeng sawingpalad at ang kerida naman ay kerido na tumutukoy sa lalakeng umiibig.

Sa puntong ito, ipinapakita na ang babae lamang ang indibidwal na gumagawa ng mga imoral na gawain. Siya ang ugat ng kasamaan sa mundo, bagay na siyang makikita rin sa katuruan ng Simbahan.

Ayon nga kay Casimiro Dias, isang Augustiniyanong misyonaryo dito sa Pilipinas noong panahon ng Kastila: "Ang babaeng Filipina ang siyang pinakahalimaw na hayop sa lahat ng nilikha ng Diyos, makasalan at pangit ang tabas ng dila. Ang pagkakaroon ng ganitong uri ng babae sa tahanan ay nangangahulugan ng kaguluhan...sapagkat saan man siya magtungo, napakaimposibleng magkaroon ng katahimikan at kapayapaan." (Boxer, 1975)

Ito marahil ang dahilan kung bakit walang lalakeng katumbas na salita ang mga nabanggit na salita sa itaas sapagkat, paniwala ng simbahan, hindi likas sa mga lalake ang maging masama at imoral na indibidwal.

Sa kabilang dako naman, dahil ang mga babae ay itinuturing na masama, kinakailangan ay maglaan sila ng maraming oras sa pagdarasal at pangalagaan ang kanyang pagkababae upang maging katanggap-tanggap sila sa paningin ng patriyarkal na lipunan. (Feliciano, 1996)

MISS vs MRS

Ang kolonyal na pamamahala ang siyang nagpabago sa katayuan ng babae sa lipunan. Noong ang mga Kastila ang siyang nanakop sa ating bansa, nilubog nila ang mga babae sa ideolohiya na sila ay nararapat sa domestikong larang lamang.

Ang mga Amerikano naman ang siyang nagbukas sa pinto sa mga kababaihan sa pampublikong aspeto. Ngunit, ang mga Amerikano din ang naging daan upang makaranas sila ng opresyon. Ang pagpapalit o paglalagay ng lebel sa katayuang sibil ng kababaihan ay nagdulot ng pananamantala sa kanila sa larang ng trabaho. Karaniwan kasi na ang mga babaeng nilalagyan ng titulo o leybel na Mrs. ay nagpapakilalang sila ay may-asawa na, dahilan upang hindi/iwasan silang tanggapin sa kumpanyang pinag-aaplayan nila. Paniwala kasi ng karamihan sa mga kumpanya, ang isang babaeng may pananagutan na ay makakabagal at makakadagdag sa gastos ng sistema ng produksyon, lalo na kung magbuntis ito. Dahil sa sitwasyong ito, ang mga babaeng may-asawa na ay nahuhulog sa pain ng mga mapang-abusong negosyante. Mababa ang sahod na inaalok sa kanila, bagay na hindi naman nila matanggihan sapagkat karamihan sa mga kumpanya ay preparableng Ms. o walang asawa ang tatanggapin sapagkat makakatipid ito sa produksyon.

Ang mga nabanggit din na titulo sa itaas ang siyang nagdidikta sa isang babae kung paano siya kumilos sa lipunang patriyarkal na ginagalawan niya. Kung siya ay walang asawa (Ms), kinakailangan ay kumilos siya ayon sa dikta ng kanyang ama o nakatatandang lalake, kung may asawa naman (Mrs.), kinakailangan ay kumilos siya ayon sa dikta ng kanyang asawa. (Feliciano, 1996).

MARIANG PALAD VS MASTURBASYON

Malaki ang impluwensya ng media sa kasalukuyan sa paghubog sa kultura ng ating bansa. Ang sinumang may kontrol nito ay magkakaroon ng kapangyarihan na diktahan ang uri

ng kamalayang nais nitong itanim sa isang indibidwal. Kaugnay nito, karamihan sa may kontrol ng media (pahayagan, telebisyon at internet) ay lalake, kaya naman pagdating sa kamalayan pagdating sa seks, hindi maiiwasan makita ang dominasyon ng kasarian nito sa pagbuo ng mga terminolohiyang may kaugnayan sa nasabing kamalayan.

Halimbawa nito ay ang salitang Mariang Palad na ginagamit bilang pamalit sa pagtukoy sa salitang pagbabati o pagdyadyakol. Malimit na gamitin ito ng mga peryodista (sa tabloid) at blogger na nagsusulat ng sekswal na babasahin. Bagamat ang proseso ng masturbasyon ay malimit na gawin ng lalake, kapansin-pansin na babae ang ginamit na pantukoy rito. Pinapakita lamang ng salita na ito na ang tingin sa mga babae ay isang sex object, ginagamit upang makaraos.

Gabay sa Non-Sexist na Paggamit sa Wikang Filipino

Ang wika ay may mahalagang papel na ginagampanan sa paghubog sa persepsyon ng isang indibidwal hinggil sa mundong kanyang ginagalawan. Ang kawalan ng kamalayan ng isang indibidwal hinggil sa mga sexist na salita sa wikang kanyang sinasalita ay magiging daan upang magkaroon siya ng isteryotayp na pagtingin sa mundo, na maaaring maging daan upang malagay sa opresyon o deskriminasyon ang isang kasarian, partikular nito ay ang mga babae.

Upang maiwasan ang bagay na ito, ang mananaliksik ay naglatag ng mga sumusunod na gabay upang magamit ang mga salita sa Wikang Filipino sa non-sexist na paraan.

1. Gumamit ng mga katutubong salita upang tumbasan ang mga sexist na hiram na salita.

Sexist na Salita sa Filipino	Katumbas na Gender Neutral na Salita
Yaya	Tagapag-alaga
Mutsatsa	Kasambahay

2. Gumamit ng mga eupemismo

Sexist na Salita sa Filipino	Katumbas na Gender Neutral na Salita
Putangina	Tagapagbigay ng panandaliang aliw
Disgrasyada	Walang katuwang sa buhay
Maybahay	Katuwang sa buhay, kabiyak ng puso

3. Manghiram ng dayuhang salita at iayon ito sa ortograpiyang Filipino

Sexist na Salita sa Filipino	Katumbas na Gender Neutral na Salita
Mariang palad	Masturbasyon

4. Pagpapanatili sa titulo ng pagkadalaga

Sexist na Salita sa Filipino	Katumbas na Gender Neutral na Salita
Ms./Mrs.	Ms.

PAGLALAGOM AT KONGKLUSYON

Napatunayan sa pag-aaral na ito na ang wikang Filipino ay isang sexist na wika, na ang pagiging sexist ng mga salita nito ay nagdedeskrimina sa mga kababaihan.

Sa tulong ng UP Diksiyunaryo (Binagong Edisyon 2010), nakita ang ilang mga sexist na salita sa nasabing wika. Ilan sa mga ito ay nagpapakita ng pagiging mababang uri ng mga babae, gaya ng mga sumusunod: puta, disgrasyada, at kerida.

Ang ilang sexist na salita naman ay nagpapakita ng isteryotayping sa gawain o trabaho. Hal nito ay ang yaya, at mutsatsa na na-isteryotayp na bilang gawaing pambabae.

May ibang sexist na salita naman na tumutukoy sa pag-uuri sa babae ayon sa katayuan nito sa lipunan. Hal nito ay ang titulong Ms. at Mrs. na malimit ikabit sa mga babae.

At ang huli, ang Mariang Palad (isang sexist na salita) na nagtuturing sa babae bilang isang sex object.

Kaugnay nito, ang mga nasabing salita na nasa itaas ay mga hiram na salita. Pinapakita lamang nito na hindi likas sa wikang sinasalita natin ang pagiging sexist, bagay na siyang mauugat natin sa egalitaryang sistema ng ating lipunan sa panahon ng ating mga ninuno. Nangyari lamang ang pagiging sexist nito noong pinalitan ng mga dayuhang mananakop (Amerikano at Kastila) ang sistema ng ating lipunan ng patriyarkal. Kasabay nang pagkontrol ng mga dayuhang mananakop sa sistema ng produksyon ng ating lipunan ay ang pagpunla naman ng makalalakeng ideolohiya sa lahat ng aspeto ng ating lipunan: kultura, pamilya, edukasyon, paniniwala at higit sa lahat – wika.

Ang wikang Filipino ay binubuo ng mga iba't ibang katutubong wika, kaya naman higit nating mapagyayaman ito kung gagamitin natin ito bilang pamalit sa mga hiram na sexist na salita. Ang pagsusulong ng gender neutrality sa paggamit ng wikang Filipino ay magsisimula sa pagpapayabong sa paggamit ng mga katutubong wika ng ating bansa, lalo na sa digital na talastasan.

SANGGUNIAN

Almario, V. S. (2010). *UP Diksiyunaryong Filipino*, Binagong Edisyon. Quezon, City: Unibersidad ng Pilipinas.

Anonuevo, C. M. (1990). *Ideology and Cultural Practice*.

Claudio, S. E. (1990). *The Psychology of the Filipino Woman*.

Ehrenreich, B. (1976, June 3). *What is Social Femenism?* WIN MAGAZINE.

Eviota, E. U. (1994). *Sex and Gender in Philippine Society*. Manila: National Commission on the Role of the Filipino Women.

Lei, X. (2006). *Sexism in Language*. *Journal of Language and Linguistics*, 87-94.

ONLINE NA PAGTUTURO NG FILIPINO: MGA HAMON AT ESTRATEHIYA

Dr. Eriberto R. Astorga Jr.

INTRODUKSYON

Ang kasalukuyang nararanasang pandaigdigang problema sa kalusugan na Covid19 ay malaki ang naging epekto sa sistema ng edukasyon sa 87% ng populasyon ng mga mag-aaral sa mundo, o 1.5 bilyon ng mga mag-aaral na apektado ng pagsasara ng mga paaralan (UNESCO, 2020). Habang pansamantalang nagkaroon ng distance at remote learning program sa iba't ibang bahagi ng bansa. Ang mga mahihirap na mga kabataan ang inaasahang higit na maaabot ng programang ito.

Sa Pilipinas, sinigurado ang kapakanan ng higit sa 27 milyong mag-aaral ng basic education sa gitna ng banta ng Covid19. Ayon sa UNESCO: "Education cannot wait. If learning stops, we will lose human capital."

Ang Sangay ng Edukasyon ay nagpabatid sa paniniwala ng UNESCO ukol sa pagkakaroon ng dekalidad na edukasyon, madaling akses at malakas na sistema ay hindi makokompromiso sa panahong nakararanas ng pandemya (UNESCO 2017). Kaya naman ang Sangay ng Edukasyon ay nanindigan sa kanilang komitment sa pagkakaroon dekalidad na edukasyon at madaling akses na nakaangkla sa balangkas ng Sulong Edukalidad. Tuloy-tuloy ang paglikha ng mga 21st Century skills na mga Pilipinong mag-aaral, ang kawani ng Kurikulum Debelopment ay sinigurado ang mga kasanayang pampagkatuto ay may kaugnayan at naaakma upang matugunan ang pangangailangan ng mga mag-aaral.

Isa sa paghahandang naisagawa ay ang pagkakaroon ng mga kompetent na guro na kayang makisabay sa tinatawag na Distance Education. Mga gurong handa sa pagbabago, may kasanayang gumamit ng mga makabagong teknolohiya upang magkaroon ng akses sa mga mag-aaral at may kahusayan sa pagresolba ng mga hamong kanilang kahaharapin sa pagtuturo.

Sasagutin ng pananaliksik na ito ang sumusunod na mga tanong:

- (a) Ano-ano ang mga karanasan ng mga gurong nagtuturo ng Filipino online?
- (b) Ano-ano ang mga hamong nararanasan ng mga guro sa pagsasagawa ng klase online?
- (c) Ano-ano ang mga estratehiyang ginagamit nila upang makapagturo online sa kabila ng mga hamong nararanasan?

Ang sumusunod na mga tanong ay maglalahad ng mga karanasan ng mga guro sa pagtuturo online, mailantad din ang kanilang mga hamong nararanasan at ang mga estratehiyang kanilang ginamit upang masolusyunan ang mga hamon sa pagtuturo online.

KAUGNAY NA LITERATURA

Hindi naging hadlang ang pandemya upang maipagpatuloy ng mga Pilipinong kabataan ang kanilang pag-aaral. Ang kagawaran ng Edukasyon ang nanguna upang hindi maantala ang pagpasok ng mga kabataang nagnanais makapagtapos ng kanilang pag-aaral.

Ang Distance Learning ang naging solusyon ng pamahalaan upang maipagpatuloy ang naantulang pasukan.

Ano ba ang Distance Learning? Ayon sa Merriam Webster ito ay isang paraan o modality na kung saan ang guro at mag-aaral ay hindi nagkklase sa loob ng silid-aralan bagkus isinasagawa ang pag-aaral sa pamamagitan ng internet, email, atbp.

Sang-ayon din sa Modyul ni Moore na “Moore’s Model of Interaction” binigyang kahulugan niya ito bilang ugnayang guro at mag-aaral. Paghihiwalay sa bawat isa na nagpapakita ng natatanging pag-uugali ng edukasyon sa distansya, (Moore & Kearsley, 2005, p. 224). Inisa-isa niya rin sa kanyang artikulo ang tatlong ugnayang nagaganap sa pagitan ng guro at mag-aaral sa Distance Education: una; ugnayang mag-aaral-nilalaman, ikalawa; ugnayang mag-aaral-guro, at ikatlo; ugnayang mag-aaral-mag-aaral Moore (1989).

Sa sistema ng edukasyon sa Pilipinas, napakahalaga ng ikalawang ugnayan sa Distance Education. Ang ugnayang mag-aaral at guro, nakapokus ito sa pagpapalawak ng pang-unawa at pananaw sa paksang kanyang tinatalakay.

Binigyang diin din ni Moore na magiging epektibo ang pagtuturo at pagkatuto sa Distance Education depende sa sistema ng interaksyon at delibero sa pagtuturo gamit ang teknolohiya sa online na klase (Moore & Kearsley, 2005).

May tatlong uri ng modalities na nakapaloob sa Distance Learning ito ay ang mga (1) Modular Distance Learning, maaaring gumamit ang mga mag-aaral ng mga self-learning module na maaaring printed o digital format. (2) Online Distance Learning, pagtuturo ng mga guro sa mga mag-aaral gamit ang internet. Maaaring i-download ang mga learning material at magpasa ng takda online upang maging aktibo ang mga mag-aaral. (3) TV/Radio Based Instruction, ang mga self-learning module ay maaaring maituro at maipalabas sa telebisyon at mapakinggan sa radio (DepEd Edukalidad).

Ang platform na Online Distance Learning ay naging gamitin sa mga mag-aaral sa panahong ito ng pandemya dahil sa ipinatutupad na No Face to Face Classes. Hindi maitatangi na ang paggamit nito ay naging malaking responsibilidad hindi lamang sa Kagawaran ng Edukasyon bagkus higit sa mga guro na silang kasangkapan upang maipagpatuloy ang edukasyon. Naging hamon ito para sa kanila, lalo na sa mga gurong nasanay na sa tradisyunal na pagtuturo. Ayon kay Efren J. Domingo sa kanyang artikulo “Kinamusta ko ang mga beteranong guro namin sa paaralan dahil sila ang una kong naisip noong ipatutupad ang online classes. Sa dami ng kanilang hinaing, napatunayan ko na sanay talaga silang magsulat mula blackboard hanggang kwaderno. Sa totoo lang, kailangan nila ng gabay. Bukod sa proseso at pag-aaral sa online platforms, iniisip din nila ang kanilang kalusugan at pamilya.” (Manila Today, Agosto 26,2020).

Kung nararanasan ito ng mga guro sa siyudad lalo’t higit ng mga guro sa kanayunan, “Sa ilalim ng distance learning, maaaring gumamit ang mga paaralan ng online platforms, printed at digital module, telebisyon at radyo. Pero wala umang signal ng internet at cellphone sa lugar para sa online class. Hindi rin masagap ang mga signal ng radio stations, at halos lahat ng mga bahay ng mga Mangyan ay walang radyo at telebisyon.” (Denis Datu, June16, 2020 Patrol.Ph).

Sa kabila ng mga hamong ito, patuloy pa rin ang pagsusumikap ng mga guro na magampanan ang kanilang propesyong sinumpaang. Hindi sila tumitiig sa paghahanda ng mga estratehiyang magagamit upang malampasan ang mga hamong ito dulot ng nararanasan sa online na pagtuturo.

Naging instrumento upang mapabilis ang pagtuturo at pag-aaral ay ang paggamit ng mga social media gaya ng Group Chat, Messenger, Google Meet, Teams at iba pang online platforms. Buong mundo ay nakararanas sa pagbabagong ito na tinatawag na Distance Learning gamit ang iba't ibang gadget. Sa Pilipinas, sinigurado ang kapakanan ng higit sa 27 milyong mag-aaral ng basic education sa gitna ng banta ng Covid19.

Mahirap man para sa mag-aaral ang pagbabagong ito ngunit hindi maitatangi na hindi rin naging madali para sa mga guro na makisabay sa distance learning. Sa pag-aaral na isinagawa ni Adada Shatila, Nisrine Nabih, (2007), natukoy niya na karamihan sa mga guro ay nakatatanggap ng higit na suporta sa panahon ng face to face professional development kaysa sa naisagawang online professional development. Gayunpaman, natukoy niya rin sa kanyang pag-aaral na sa kabila ng kakulangan ng suporta sa mga guro ay naisagawa pa rin nilang iintegrate ang teknolohiya sa pagtuturo.

Ayon din kay Gannaban, M. E. (2012), "Maaaring magbigay ng oportunidad ito sa mga guro upang kumonekta sa mga mag-aaral ngunit ang koneksyon ay may parametro ang ugnayang guro-mag-aaral."

Sa kabila ng hamon ng online learning ang mga guro ay hindi tumitigil sa paghubog ng kanilang sarili upang maging handa sila sa kanilang pagtuturo. Ukol kay Papa, N. P.. (1985), "Hindi gawang biro ang maging isang guro, sa dahilang sa gawaing ito, ang hinuhubog natin ay tao..."

Isa ang mga guro sa Filipino na maituturing na handa sa anomang pagbabagong nagaganap lalo na sa usapin ng kanilang pagtuturo. Napatunayan ito sa ginawang saliksik ni Gannaban, M. E.. (2012), "ayon sa mga mag-aaral na ang mga kagamitang panturo ay hindi nakapag-aambag ng kahusayan sa pagtuturo ng mga guro sa Filipino dahil naiintindihan nila ang itinuturo kahit walang biswal, ngunit ayon sa persepsyon ng mga guro at tagapamahala ay nakatutulong ang mga kagamitang panturo sa kahusayan sa pagtuturo ng mga guro sa Filipino."

Sang-ayon din sa isinagawang pag-aaral nina MacIntyre, P. D., Gregersen, T., & Mercer, S. (2020), sa kabila ng mga hamon sa pagtuturo online gaya ng stress, anxiety at iba pa ay patuloy ang pagtanggap ng mga guro ng wika sa kanilang mga nararanasang. Ito ang paraan nila upang malampasan ang mga pagsubok sa pagtuturo online.

Tinukoy nila Carlson, S., & Gadio, C.T. (2003) na, "Ang paghubog ng propesyunal na debelopment ng mga guro ay ganap na mahalaga kung ang bawat teknolohiya ay naibigay nang maayos sa bawat paaralan. Gastusan ang pangangailangan nila sa information teachnology..." Sang-ayon sa pag-aaral ni Petras, J. (2012), "Malinaw ang bentahe sa pagpapasigla ng pagtuturo at pagkatuto sa wikang Filipino..."

Hindi madali ang nararanasang hamon ng mga guro sa panahong ito na online ang pagtuturo, ngunit sa kabila ng mga ito patuloy pa rin ang paghahanda ng nila upang maibigay ang dekalidad na edukasyon sa kanilang mga mag-aaral.

METODOLOHIYA

Disenyo ng Pananaliksik

Ang pananaliksik na ito ay isinagawa ayon sa disenyo ng Qualitative Research. Penomenolohikal na pamamaraan ang ginamit, tinangkang ilarawan at suriin ng mananaliksik

sa pag-aaral na ito ang mga hamon at estratehiyang ginamit ng mga guro ng Filipino, sa pagtuturo online.

Mga Tagatugon

Purposive Sampling ang pagpili sa anim (6) na guro ng asignaturang Filipino. Apat (4) sa kanila ay lalaki at dalawang (2) babae. Silang lahat ay mga guro sa Filipino mula sa Kolehiyo ng Edukasyon at Departamento ng Filipino. Ang pagsagot nila ay naaayon sa kanilang bakanteng araw at oras. Itinago ang kanilang pangalan sa pamamagitan ng code na F1, F2, F3, F4, F5, F6.

Instrumento ng Pananaliksik

Ang pag-aaral na ito ay isinagawa sa pamamagitan ng Questionnaire (Talatanungan). Ang mananaliksik ay naghanda ng mga tanong upang malaman ang mga karanasan, hamon at estratehiya sa pagtuturo online ng mga guro ng Filipino. Ipinasagot ang mga tanong sa pamamagitan ng Google Forms na ipinasa sa kanilang email account.

Para sa lalong pagpapabuti ng pag-aaral ay nangalap ang mananaliksik ng mga impormasyon sa iba't ibang lunsaran gaya ng libro, lathalain, kaugnay na pag-aaral at iba pa.

Paraan ng Pangangalap ng Impormasyon

1. Bumuo ng layunin at research questions (talatanungan) upang matukoy ang mga karanasan, hamon at estratehiyang ginamit ng mga guro ng Filipino sa pagtuturo online.
2. Pinabalideyt ang mga tanong sa mga Dalubguro sa Filipino
3. Nagkaroon ng pagpupulong ang mga guro at ang mananaliksik gamit ang Google Meet, hiningi ang pahintulot ng mga kalahok sa isinagawang Google Forms.
4. Pinamahagi ang talatanungan sa pamamagitan ng Google Forms, kalakip nito ay ang liham sa paghingi ng pahintulot.
5. Pinabasa ang mga nakalap na mga sagot.
6. Pinag-isa-isa ang mga nakalap na sagot sa mga tanong sa pamamagitan ng pagtatranskrip ng mga ito.

RESULTA AT DISKUSYON

Maikli lamang ang panahong ginugol sa kasalukuyang pag-aaral, kaya hindi sapat ang datos na nalikom upang ipalagay ang pangkalahatang resulta nito hinggil sa hamon at estratehiya sa pagtuturo ng mga Guro sa Filipino. Tulad ng nabanggit sa panimula ng pag-aaral, isang eksploratoryo ang kasalukuyang pag-aaral kaya pinapangahasang sabihin ng mananaliksik na nangangailangan pa ito ng mahaba-habang panahon upang dalumatin, sipatin, at limiing mabuti ang mga resultang natamo.

Anim na guro lamang ang nakapanayam ng mananaliksik: anim na guro mula sa Eulogio Amang Rodriguez Institute of Science and Technology-College of Education at Departamento ng Filipino. Ang mga nainterbyung guro ay nagtuturo sa Filipino. Mayroong mga

tanong upang malaman ang karanasan, hamon at estratehiya ng mga guro. Sinagutan nila ito sa pamamagitan ng Google Forms. Habang isinagawa ang pag-aaral na ito, natuklasan na:

(Notasyon: Nakalahad sa itaas ang transkripsyon ng talatanungan sa anim na guro hinggil sa mga karanasan, hamon at estratehiya ng mga guro ng Filipino sa pagtuturo online. Gumamit ang mananaliksik ng Code; hal.F1 para sa pagtukoy ng isang tagatugon)

Karanasan

Nakatutuklas ng mga makabagong paraan sa patuturo gamit ang iba't ibang uri ng mobile applications at online platform. Nagkaroon ng oras sa pag-attend ng mga webinar para sa pagpapaunlad ng kaalaman sa paggamit ng mga makabagong teknolohiya na magagamit sa pagtuturo online. Limitado ang oras sa pagtuturo online kung kaya't nakaiisip ng mga paraan kung paano lilimitahan ang pagtalakay na nauunawaan ng mga mag-aaral.

“Nakatutuklas ng mga bagong apps na ginagamit sa pagtuturo at nakadadalo ng mga webinar” (F1, F3, F4)

Hamon

Karamihan ay nakararanas ng interapsiyon ng koneksiyon ng internet, narito ang sumusunod na epekto sa kanilang pagtuturo online.

1. Hindi pagdalo sa synchronous na klase
2. Madalas na pagla-log ng guro at mag-aaral
3. Hindi pagkakaunawaan dahil sa hina ng volume o sounds

Kawalan ng interes o hindi aktibo sa klase ng mga mag-aaral; hal, hindi pagpapasa ng sa takdang oras ng mga gawain, hindi pakikilahok sa talakayan at iba pa. Kahirapan sa komunikasyon sa mag-aaral at magulang

“Hina ng Internet Connection gayundin ang paminsan-minsang pagkawala ng pokus ng mga mag-aaral.” (F1, F3, F4, F5)

Estratehiya

Halos lahat ng tagatugon (6 guro) ng/sa Filipino na nagsasabing sila ay nakilahok sa mga Webinar, Workshop upang maihanda ang kanilang sarili sa pagkatuto ng paggamit ng online platforms dahil ang pamaraang gagamitin sa pagtuturo ay sa pamamagitan ng birtuwal na pagkatuto.

Dinibelop din nila ang kanilang sarili sa pamamagitan ng panonood ng mga Youtube, Google at Mobile Application upang maging handa sa pagtuturo gamit ang mga teknolohiya. Nagbasa rin sila ng librong may kinalaman sa Distance Learning, gayundin din ang pagkonsulta sa mga eksperts na guro sa teknolohiya.

Paggamit ng reinforcement gaya ng pagbibigay ng mga karagdagang puntos sa bawat positibong ginagawa/nagagawa ng mga mag-aaral at pagiging positibo ng mga guro sa kabila ng mga hamong nararanasan.

“Pagsasagawa ng Plano, wastong paggamit ng oras, gumagamit ng iba't ibang paraan upang mapadali ang mga araling itinaturo sa araw-araw.” (F2)

“Pagiging positibong guro, pagbibigay ng puntos sa mga mapamaliit o mapamalaki nilang gawain.” (F6)

KONGKLUSYON AT REKOMENDASYON

Mula sa isinagawang questionnaire (talatanungan), makikita na:

Sa pag-aaral na ito natukoy na limitado ang akses ng mga guro sa mga mag-aaral dahil sa problema ng koneksiyon ng internet. Karamihan ay nagsasabi na kakaunting bilang lamang ng mag-aaral ang pumapasok sa synchronous na klase. Kulang din ang akses sa komunikasyon sa mga magulang. Hindi gaanong aktibo ang mga mag-aaral sa klase at nagkakaroon ng hindi pagkakaunawaan sa panuto ng mga gawain.

Gayunpaman halos lahat ng respondent (6 guro) ng/sa Filipino na nagsasabing sila ay nakilahok sa mga Webinar, Workshop upang maihanda ang kanilang sarili sa pagkatuto ng paggamit ng teknolohiya dahil ang pamaraang gagamitin sa pagtuturo ay sa pamamagitan ng birtuwal na pagkatuto.

Dinibelop din nila ang kanilang sarili sa pamamagitan ng panonood ng mga Youtube at Google Application upang maging handa sa pagtuturo gamit ang mga teknolohiya. Nagbasa rin sila ng librong may kinalaman sa Distance Learning, gayundin din ang pagkonsulta sa mga eksperts na guro sa teknolohiya.

Patuloy silang gumagawa ng paraan upang malampasan ang mga hamon na kanilang kinaharap sa birtuwal na pagtuturo. Dahil sa mga balakid na ito nadaragdagan ang kanilang kaalaman.

Ang pagiging guro ay hindi madaling propesyon, lalo na ngayon na online ang pagtuturo. Sa paghahanda ng mga kakailanganing gawin sa mga hamon ng online na klase higit na kailangan ang pagtutulungan ng lahat ng stakeholder. Hindi lamang sa guro nakasalalay ang pagkatuto ng mga mag-aaral sa panahong ito.

Kaugnay ng isinagawang pag-aaral, buong pagpapakumbabang iminumungkahi ng mananaliksik na:

1. Para sa Guro. Magkaroon pa nang higit na paghahanda ang mga guro upang lalo nilang matutuhan ang paggamit ng teknolohiya para sa pagtuturo online. Sa gayon mapauunlad nila ang kanilang kasanayan sa paggamit ng mga ito sa paghahanda sa mga hamon na kanilang kakaharapin gamit ang mga online platforms. Pagbibigay ng mga libreng short courses sa mga guro na may kinalaman sa paggamit ng iba't ibang social media platform upang higit silang magkaroon ng masteri sa paggamit ng mga ito.

Pagkakaroon ng badget ng mga gawain para magamit nang mabuti ang oras sa pagtalakay ng aralin.

Pagkakaroon ng seminar sa Mental Health na ang pokus ay sa pagpapahalaga ng mga guro sa kanilang mentalidad sa panahong nakararanas sila ng stress o anxiety dulot ng mga hamong nararanasan sa pagtuturo online.

2. Para sa Magulang. Pakikipag-ugnayan sa guro o paaralan para sa debelopment ng kanilang mga anak lalo na ngayon na online lamang pagkikita ng guro at mag-

aaral. Higit na kailangan ang gabay ng magulang sa panahon ng distance learning. May social media gaya ng Group Chat, Facebook page at iba pa maaaring maging paraan sa pakikipag-ugnayan sa guro.

Pag-aaral ng paggamit ng mga online platforms gaya ng Google Classroom para malaman kung nagagawa ng mga anak ang mga gawaing ibinibigay ng mga guro. May Youtube o Google kung hindi nalalaman ang paggamit nito.

3. Para sa Mag-aaral. Marapat na makilahok sa mga gawaing pampaaralan, ipagbigay alam sa guro ang dahilan ng pagliban sa synchronous na klase upang magawan ng solusyon, May group chat para maisangguni ang mga nais sabihin. Maging matapat din sa mga magulang

MGA SANGGUNIAN

Adada Shatila, Nisrine Nabih, "THE ROLE OF TECHNOLOGY IN TEACHERS' PROFESSIONAL DEVELOPMENT" (2007). Dissertations. 1259.

Arinto, P. (2016). Issues and Challenges in Open and Distance e-Learning: Perspectives from the Philippines. *International Review of Research in Open and Distributed Learning*, 17 (2), 162–180.

Carlson, S., & Gadio, C.T. (2003). Teacher professional development in the use of technology. [Online]. *Technologies for Education*. Available: [www. TechKnowLogia.org](http://www.TechKnowLogia.org).

Gannaban, M. E. (2012). Isang Pagsusuri sa Persepsyon sa at Aktwal na Kahusayang Pampagtuturo ng Guro. *DALUMAT E-Journal*, 3(1-2).

http://amandaszapkiw.com/elearning/principles-of-design/module-1/moores_model_of_interaction.html K12 MELC with corresponding CG codes and guidelines

MacIntyre, P. D., Gregersen, T., & Mercer, S. (2020). Language teachers' coping strategies during the Covid-19 conversion to online teaching: Correlations with stress, wellbeing and negative emotions. *System*, 94,102352.

Papa, N. P.. (1985). Mga Pagpapahalagang Dapat Angkinin ng Isang Guro. *MALAY*, 4(1-2).

ASSESSMENT OF STUDENT ENGAGEMENT AND DELIVERY OF INSTRUCTION IN HIGHER EDUCATION: BASIS FOR FLEXIBLE LEARNING PROGRAM

*Daisy Mae R. Bongtiwon
Derick O. Peralta
Centrey L. Ramos
Elsa R. Cagatan*

INTRODUCTION

UNESCO defined distance learning (or Distance Education, also ODL for Open and Distance Learning) as a field of education that focuses on the pedagogy, technology, and instructional systems design that aim to deliver education to students who are not physically "on site". It is a process where students receive instruction through online classes, video recordings, video conferencing, or any other audio/visual technology medium. It enables people to receive education without having to be physically present in a classroom. Hence the term Online Distance Learning.

During the COVID-19 pandemic, when schools are closed for long periods of time, one of the important concerns that emerged aside from academics, educational programs and student assessment is how to preserve students' motivation, engagement and interest. In this time of crisis, many students have experienced anxiety which resulted to their loss of interest to continue learning. This has led to questions about the necessity, importance and usefulness of certain curriculum content. Hence, relevance of certain trends, particularly the authenticity of learning situations has been emphasized.

Addressing this concern, teachers and school administrators may refer to the UN's 2030 Agenda Sustainable Development Goals (SDGs) for contextualized and authentic learning situations relating to the major challenges facing humanity. Flexible, wide-ranging and authentic learning activities (COVID-19 experiences during lockdowns) could be used to contextualize student realities during the pandemic and may be basis to rethink curricular content and approaches.

According to Delfino (2019), student engagement is a key determinant in students' success in higher education. Active participation and purposeful effort toward all aspects of their learning may lead to high academic performance. It has been proven that student engagement improves academic performance.

Due to Covid-19, many schools, colleges, and universities have shifted their learning mode from face-to-face to online classes. Online classes include the educational technology that we have today. It has been discovered that educational technology can help students learn more effectively. However, Hew et al. (2019) request more theoretical guidance as to educational technology's role in affecting education. In order to improve learning results, students must be engaged (Nelson Laird & Kuh, 2018).

Student engagement is a broad and complicated construct (Ben-Eliyahu et al., 2018), with three commonly accepted dimensions: affective, cognitive, and behavioral houses a variety of engagement and disengagement indicators. Although technology can boost student involvement, strong teaching and careful preparation are required (Howard et al., 2016;).

Fredricks, Blumenfeld, and Paris (2004) defined three categories of student engagement: affective, cognitive, and behavioral engagement.

- Behavioral engagement covers students' participation in lessons, such as attendance and concentration levels, their involvement in social aspects of learning, and whether or not they engage with other activities.
- Emotional engagement covers students' feelings, especially towards the subject or course they are studying, their teachers, peers, their overall academic experience, and whether or not they feel the lessons have value.
- Cognitive engagement covers students' motivation and investment in their education. It also includes the extent to which they take ownership of their learning, can self-regulate, and wish to pursue personal, educational goals.

Digital games, web-conferencing software, and Facebook (Schindler, Burkholder, Morad, & Marsh, 2017) have been found to predict increased student engagement as well as studies on audience response systems (Hunsu, Adesope, & Bayly, 2016). However, careful planning and strong pedagogy are required to make this possible; otherwise, technology might obstruct rather than aid learning, leading to disengagement (Howard, Ma, & Yang, 2016).

Educators can better create classes and courses that will interest students and lead to improved outcomes by identifying characteristics that positively contribute to student engagement when employing technology. These include ensuring a sufficient level of challenge in tasks, educators having sufficient ICT skills and confidence (Howard et al., 2015), being prepared and using well-designed tasks (Rashid & Asghar, 2016), using humor in online teaching in particular (Imlawi, Gregg, 2014), and providing clear explanations as to why the technology is being used. Having said all these things, educators should provide quality instruction even in an Online Distance Learning modality.

Based on Sogunro's (2017) content analysis, quality instruction is delivered by a competent instructor rooted in content, facilitating the discovery and depth of new knowledge by students in a Motivating Factors constructivist manner. It also means that the teacher can effectively engage students in the learning process and relay relevant knowledge. It does not only consist of lecturing to students or reading slides from a PowerPoint. Quality instruction should be dynamic—using different delivery styles. The delivery of instruction must evoke students' interest, critical thinking, and learning in a meaningful way. It makes students curious and excited about what they are doing, enabling them to discover learning and take ownership of their education. Lastly, quality instruction is one that an expert in the content area facilitates, uses best teaching practices, has clear and high expectations for students, and relates theory to practice.

The relationship between student engagement and the quality of instruction delivery is the paper's primary goal. It is in this premise that this paper has been conceptualized.

STATEMENT OF THE PROBLEM

This research aimed to investigate student engagement and the delivery of instruction in an Online Distance Learning (ODL) in the College of Education of the Eulogio “Amang” Rodriguez Institute of Science and Technology (EARIST) during the second semester of SY 2020 - 2021, which will serve as basis for developing and implementing a flexible learning program. This study sought to answer the following questions:

How did respondents evaluate the delivery of instruction during online classes?

1. How did the respondents assess class engagement during online classes?
2. Is there a relationship between the assessments on student engagement and delivery of instruction during online classes?
3. What flexible learning program can be developed based on the findings in order to improve student engagement and delivery of instruction during online classes?

METHODOLOGY

The study used quantitative research method to examine students' assessment on student engagement and delivery of instruction during Online Distance Learning (ODL). Data were gathered using a survey questionnaire administered through Google forms. The survey questionnaires were adapted from Aristovnik A, Kerzic D, et al. (2020), and Jeongju Lee et al. (2019). The survey captured respondents' assessment and perception on how remote learning has impacted students' classroom engagement and delivery of instruction.

The study surveyed 106 students from the College of Education (CED) of Eulogio "Amang" Rodriguez Institute of Science and Technology (EARIST) enrolled during the second semester of SY 2020 - 2021. Specifically, Bachelor in Secondary Education major in Science (BSE-Science) – 42 students, Bachelor in Secondary Education major in Mathematics (BSE-Math) – 27 students, and Bachelor of Technology and Livelihood Education (BTLED) – 37 students.

Both descriptive and inferential statistics were used to analyze the survey results. A correlational test was performed to determine the significant relationship between students' assessment of classroom engagement and delivery of instruction in an Online Learning Mode.

RESULTS AND DISCUSSION

SOP 1: How did students evaluate the delivery of instruction during online classes?

It can be gleaned from Table 1 that the mean ratings of BSE-Science, BSE-Math, and BTLED students were 3.57, 3.51, and 3.59, respectively, all with a descriptive interpretation of "very satisfactory". Moreover, the overall mean rating is 3.56, which is also rated "very satisfactory". This implies that the delivery of instruction during the online distance learning is very satisfactory as assessed by the respondents. However, looking at the numbers, these values are just above the "satisfactory" level. Hence, delivery of instruction still requires enhancement so that students can maximize learning during ODL.

Table 1
Assessment of Students on the Delivery of Instruction during Online Class

Respondents	Weighted Mean	Verbal Interpretation
BSE-Science	3.57	Very Satisfactory
BSE-Math	3.51	Very Satisfactory
BTLED	3.59	Very Satisfactory
Overall Weighted Mean	3.56	Very Satisfactory

Legend: 4.20-5.00 = Excellent (E), 3.40-4.19 = Very Satisfactory (VS), 2.60-3.39 = Satisfactory (S), 1.80-2.59 = Fair (F), 1.00-1.79 = Needs Improvement (NI)

Delivery of instruction is a means to achieve higher student performance. Effective teachers play a pivotal role in students' lives; therefore, it is essential to continue offering professional growth activities to build the capacity and repertoire of teachers as described by Stronge (2018) in *Qualities of Effective Teachers*. Professional development for teachers is in keeping with the philosophy that planning and preparation will increase student engagement (Marzano, 2012).

SOP 2: How did the students assess class engagement during online classes?

Table 2 illustrates the mean ratings of the respondents on classroom engagement during Online Distance Learning. The BSE-Science, BSE-Math, and BTLED students rated their online classroom engagements with 3.49, 3.40, and 3.47, respectively, all interpreted as "moderate". Moreover, the table shows an overall weighted mean rating of 3.45, which is interpreted as a moderate level of engagement.

Table 2
Assessment of Students on Student Engagement during Online Class

Respondents	Weighted Mean	Verbal Interpretation
BSE-Science	3.49	Moderate
BSE-Math	3.40	Moderate
BTLED	3.47	Moderate
Overall Weighted Mean	3.45	Moderate

Legend: 4.20-5.00 = Very High (VH), 3.40-4.19 = High (H), 2.60-3.39 = Moderate (M), 1.80-2.59 = Low (L), 1.00-1.79 = Very Low (VL)

Sogunro (2017) stated that quality instruction means that the teacher can effectively engage students in the learning process and relay relevant knowledge. It does not only consist of lecturing to students or reading slides from a PowerPoint. Quality instruction should be dynamic—using different delivery styles.

SOP 3: Is there a relationship between the assessments on student engagement and delivery of instruction during online classes?

Correlational analysis using the Pearson's Correlations Coefficient derived a rating of $r = 0.27$, which implied that there is a weak correlation between student engagement and the delivery of instruction.

Canales (2020) said that student engagement is an essential component of student learning. She also found out that Student Engagement had yielded varying degrees of correlation in association to the Instructional Delivery compared to the Student Engagement indicators, which generated weak correlations. She suggested that additional research is needed to identify which instructional strategies may predict higher levels of student engagement in the classroom. She also mentioned that professional development in explicit instruction, use of questioning, providing feedback, and use of technology is critical to building teacher capacity, especially in an Online Distance Learning mode.

SOP 4: What flexible learning program can be developed based on the findings in order to improve student engagement and delivery of instruction during online classes?

Since there is a weak correlation between student engagement and delivery of instruction, a flexible learning program will enhance both the quality of instruction and student engagement during Online Distance Learning. The flexible learning program is composed of teaching and learning strategies of students while attending Online classes. The program covers the three programs involved in the study, namely BSE- Science, BSE-Math, and BTLED.

CONCLUSION

Based on the findings, students have evaluated the delivery of instruction during online classes as very satisfactory. Also, students assessed the class engagement during online classes as moderate only. Using the Pearson Correlation Coefficient, the relationship between student engagement assessment and instruction delivery is weak. These results corroborate the need for a Flexible Learning Program that could alleviate student engagement and enhance quality of instruction during online distance learning.

RECOMMENDATION

As mentioned by Canales (2020) in her study, instructional strategies that increase levels of student engagement in the classroom and observational tools and techniques that corroborate various forms of engagement during online classes should be the foundation in developing a flexible learning program not only for the College of Education, but for all the colleges of the institution. Likewise, building teacher capacity is imperative, hence, professional development in specific areas such as explicit instruction, use of questioning, providing feedback, and use of technology should be incorporated in the program.

REFERENCES

- Aristovnik, Aleksander & Keržič, Damijana & Ravšelj, Dejan & Tomažević, Nina & Umek, Lan. (2020). Impacts of the COVID-19 Pandemic on Life of Higher Education Students: A Global Perspective. 10.20944/preprints202008.0246.v2. <http://www.covidsoclab.org/wp-content/uploads/2020/06/Covid19-Methodological-Framework-17062020.pdf>
- Ben-Eliyahu, Adar & Moore, Debra & Dorph, Rena & Schunn, Christian. (2018). Investigating the Multidimensionality of Engagement: Affective, Behavioral, and Cognitive Engagement Across Science Activities and Contexts. *Contemporary Educational Psychology*. 53. 10.1016/j.cedpsych.2018.01.002.
- Blumenfeld, Phyllis & Paris, Alison. (2004). School Engagement: Potential of the Concept, State of the Evidence. *Review of Educational Research - REV EDUC RES*. 74. 59-109. 10.3102/00346543074001059.
- Canales, Yanelys, "The Relationship Between Instructional Delivery And Student Engagement In Selected Classrooms: A Cross Case Analysis" (2020). *Dissertations, Theses, and Masters Projects*. Paper 1593091520. <http://dx.doi.org/10.25774/w4-z43v-zg57>
- Delfino, Armando. (2019). Student Engagement And Academic Performance Of Students Of Partido State University. *Asian Journal of University Education*. 15. 42-55. 10.24191/ajue.v15i3.05.

- Hew, Khe & Lan, Min & Tang, Ying & Jia, Chengyuan & Lo, Chung Kwan. (2019). Where is the "theory" within the field of educational technology research?. *British Journal of Educational Technology*. 50. 956-971. 10.1111/bjet.12770.
- Howard, Sarah & Ma, Jun & Yang, Jie. (2016). Student rules: Exploring patterns of students' computer-efficacy and engagement with digital technologies in learning. *Computers & Education*. 101. 10.1016/j.compedu.2016.05.008.
- Howard, Sarah & Mozejko, Adrian. (2015). Teachers: technology, change and resistance. 10.1017/CBO9781316091968.030.
- Hunsu, Nat & Adesope, Olusola & Bayly, Dan. (2015). A meta-analysis of the effects of audience response systems (clicker-based technologies) on cognition and affect. *Computers & Education*. 94. 10.1016/j.compedu.2015.11.013.
- Imlawi, Jehad & Gregg, Dawn. (2014). Engagement in Online Social Networks: The Impact of Self-Disclosure and Humor. *International Journal of Human-Computer Interaction*. 30. 10.1080/10447318.2013.839901.
- Jeongju Lee & Hae-Deok Song & Ah Jeong Hong, 2019. "Exploring Factors, and Indicators for Measuring Students' Sustainable Engagement in e-Learning," *Sustainability, MDPI, Open Access Journal*, vol. 11(4), pages 1-12, February. <https://ideas.repec.org/a/gam/jsusta/v11y2019i4p985-d205928.html>
- Marzano, Robert. (2012). The Two Purposes of Teacher Evaluation. *Educational leadership: journal of the Department of Supervision and Curriculum Development, N.E.A.* 70. 14-19.
- Nelson Laird, Thomas & Kuh, George. (2005). Student Experiences With Information Technology And Their Relationship To Other Aspects Of Student Engagement. *Research in Higher Education*. 46. 211-233. 10.1007/s11162-004-1600-y.
- Rashid, Tabassum & Asghar, Hanan. (2016). Technology Use, Self-Directed Learning, Student Engagement and Academic Performance: Examining the Interrelations. *Computers in Human Behavior*. 63. 604 - 612. 10.1016/j.chb.2016.05.084.
- Schindler, Laura & Burkholder, Gary & Morad, Osama & Marsh, Craig. (2017). Computer-based technology and student engagement: a critical review of the literature. *International Journal of Educational Technology in Higher Education*. 14. 10.1186/s41239-017-0063-0.
- Sogunro, Olusegun. (2017). Quality Instruction as a Motivating Factor in Higher Education. *International Journal of Higher Education*. 6. 173. 10.5430/ijhe.v6n4p173. https://www.researchgate.net/publication/319161454_Quality_Instruction_as_a_Motivating_Factor_in_Higher_Education
- Stronge, J. (2002). *Qualities of Effective Teachers*. Association for Supervision and Curriculum Development.

Other Internet Readings

<https://scholarworks.wm.edu/cgi/viewcontent.cgi?article=6917&context=etd>

<https://www.utica.edu/academic/Assessment/new/assessing%20engagement.pdf>

<https://files.eric.ed.gov/fulltext/EJ1151832.pdf>

APPLICATION OF WORK FROM HOME SCHEME DURING PANDEMIC AND IT'S SIGNIFICANCE TO EARIST CBA FACULTY: BASIS FOR WORK PRODUCTIVITY

Dr. Aguida V. Cabreros

INTRODUCTION

The spread of the Corona Virus which is commonly called Covid 19, was a tremendous experience for all individuals, and a lot of companies are adopting the Work from Home scheme. The said scheme is when the employees need to work in the comfort of their own homes. This is when the learning institutions also required all the teaching personnel to perform their duties in different learning modalities while anticipating their home as a classroom. This scheme has its ups and downs, which made the researchers curious about the productivity output.

First, the researchers would like to know if the Work from home scheme is as effective as actual face-to-face teaching.

Second, the researchers would like to know the advantages and disadvantages of the work from home scheme to the employee, especially to the educators.

Lastly, the researcher would like to know if there is no significant difference between Work from home to actual work in a workplace.

METHODOLOGY

This research was conducted at the College of Business Administration, Eulogio "Amang" Rodriguez Institute of Science and Technology, Nagtahan, Sampaloc, City of Manila. The objective of this study is to determine the effectiveness of the application of the Work from Home scheme in the Eulogio "Amang" Rodriguez Institute of Science and Technology under the College of Business Administration. Nagtahan, Sampaloc City of Manila .

The researcher used the descriptive research design and quantitative method. This method will help to know the insights of the faculty in the College of Business Administration regarding the effectiveness of the Work from home scheme during this global Pandemic.

The researcher used stratified sampling procedure in determining the exact sample numbers to use. The formula which shows the relation between the total population and the sample size is shown below.

$$Nn = n/N \times Nn$$

Where n = sample size
Nn = sample from a stratum
N = total population

The total number of faculty members of EARIST will be determined and confirmed when the school days were resumed. The actual number of respondents is based on the results using stratified sampling, and total of 20 faculty participated in answering the online survey by using goggle forms from College of Business Administration. The researcher used

these materials as sources of information to accomplish this study and sought to answer the following questions.

1. What do the faculty members assess the implementation of the Work from home scheme as to:

- 1.1 Objectives
- 1.2 Procedures
- 1.3 Teaching engagement
- 1.4 Monitoring?

2. What is the faculty members' performance as to:

- 2.1 Attendance
- 2.2 Students' rating
- 2.3 Superior's rating?

3. Is there a significant relationship between the implementation of the work from Home Scheme during the pandemic period and faculty members' productivity?

FINDINGS

The findings of the study were specified as follows:

1. The assessment of the implementation of work from home scheme rated as highly implemented such as: teaching engagement, and monitoring with both the overall weighted mean of 4.57; objectives with an overall weighted mean of 4.33 and procedures with an overall weighted mean of 4.30.

2. The faculty members' performance was rated as Outstanding namely: superior's rating with an overall weighted mean of 4.85; and attendance with an overall weighted mean of 4.73; while students' evaluation was rated as satisfactory with an overall weighted mean of 2.93.

3. There is a significant relationship between the implementation of work from home scheme during the pandemic and faculty members' productivity.

CONCLUSIONS

Based on the findings of the study, the following conclusions are drawn:

1. Most of the faculty members do not affect their teaching style and methods by implementing a work from home scheme. They have more time to plan, organize, and prepare their flexible course plan and actual teaching.

2. Faculty members are still effective at teaching even in work from home scheme. They can still do their tasks on time and attend their class regularly, whether it be synchronous or asynchronous modality.

3. Faculty members are still able to submit their accomplishment reports and works on time productively. They still obey their superior's rules and regulations. The researcher also concludes a significant relationship between the implementation of Work from

home during this pandemic period and the faculty members' of EARIST and their productive output.

RECOMMENDATIONS

Based on the findings and conclusion presented, the following recommendations are suggested.

1. The work from home setting still advise to continue even if the face-to-face classes resumed for some reasons, like when professors can't attend class because of something urgent or for when emergencies occur, as the use of Google classroom for posting of assignments and lessons. It's very essential to continue for the health issue for the health protection of the faculty.

2. Eulogio "Amang" Rodriguez Institute of Science and Technology must support the faculty in their needs to have a more comfortable and more effortless experience in work from home scheme by giving allowances for internet expenses and other necessary things to be used in working from home set up, since some of the faculty found working from home and online learning more productive when it comes to teaching and passing requirement.

3. For the institution to conduct more webinars on how to be healthy and productive in working at home and also for how to adapt on the usage of new technologies for more efficient work and online learning.

BIBLIOGRAPHY

Flaherty, C.(2020), Faculty Home Work, <https://www.insidehighered.com/news/2020/03/24/working-home-during-covid-19-proves-challenging-faculty-members>

Merrefield, C.(2020), Working from home: What the research says about setting boundaries, staying productive and reshaping cities, <https://journalistsresource.org/studies/economics/jobs/working-from-home-telework-research/>

Gorlick, A. (2020), The Productivity pitfalls of working from home in the age of COVID 19, <https://news.stanford.edu/2020/03/30/productivity-pitfalls-working-home-age-covid-19/>

Mautz, S. (2020), A 2-Year Stanford Study that Shows the Astonishing Productivity Boost of Working From Home, <https://www.inc.com/scott-mautz/a-2-year-stanford-study-shows-astonishing-productivity-boost-of-working-from-home.html>

Papandrea, D. (2020), Want to Work from Home? Understand the Pros and Cons before deciding, <https://www.monster.com/career-advice/article/pros-cons-of-working-from-home>

Abad, R. (2020), "Work from Home" trend climbs amid quarantine, study show," <https://businessmirror.com.ph/2020/04/28/work-from-home-trend-climbs-amid-quarantine-study-confirms/?fbclid=IwAR3SsfUB0NIFZvvRmh7rIPH2SmVbkvyB2UCSVF-j2FeBtDkcV3DUEZ7jD64>

- Sanchez, D. (2020), Working from in the Philippines: Productivity and Ergonomics, <https://kmcmaggroup.com/research-insights/2020/working-from-home-in-the-philippines-productivity-and-ergonomics/>
- Herrera III, E. C. (2020), Philippines: Alternative Work Arrangements, https://www.taylorvinters.com/article/philippines-alternative-work-arrangements?fbclid=IwAR3W15UnJAYvHsQ9tUN9gUgU108DRCzEBNOoRhsCO_-xhzAW5J6XeRves9g
- Jaymalin, M. (2020), ECQ may prompt review of Work-from-Home arrangements in Phl, https://www.onenews.ph/ecq-may-prompt-review-of-work-from-home-arrangements-in-phl?fbclid=IwAR2hWImx94MLElvD9Z_AVzx28ob-9m00HrTKIOvK86TgbiGIJSQa8xlqfvg
- Untivero, D. (2020), Opinion: Working from home...is it sustainable for the Philippines, <https://ph.asiatatler.com/life/working-from-home-is-it-sustainable-for-the-philippines>
- Ortiz, M. A. (2020), IBM Philippines and their Work from Home Program, https://www.researchgate.net/publication/305549512_IBM_Philippines_and_their_Work_at_Home_Program
- Vergina, S. D. (2020), Missing in Action: Implications for the Management of Employees Working from Home in the Philippines' BPO Industry, https://www.researchgate.net/publication/341281101_Missing_in_Action_Implications_for_the_management_of_employees_working_from_home_in_the_Philippines'_BPO_industry
- Ramos, J. P. (2020), The Impact of Work-Home arrangement on the Productivity of the Employees during COVID 19 Pandemic in the Philippines: A Structural Equation Modelling Approach, <https://dl.acm.org/doi/fullHtml/10.1145/3429551.3429568>
- Purwato, A. (2020), Impact of Work from Home on Indonesian Teachers Performance during the COVID 19 Pandemic: A Explanatory Study, https://www.researchgate.net/publication/341413246_Impact_of_Work_From_Home_WFH_on_Indonesian_Teachers_Performance_During_the_Covid-19_Pandemic_An_Exploratory_Study
- Aithal, S. (2020), An Empirical Study on Working from Home: A Popular E-Business Model, https://www.researchgate.net/publication/281524771_AN_EMPIRICAL_STUDY_ON_WORKING_FROM_HOME_A_POPULAR_E-BUSINESS_MODEL
- Bick, A. (2020), Work from Home after the COVID 19 Outbreak, <https://www.dallasfed.org/-/media/documents/research/papers/2020/wp2017.pdf>

IMPLEMENTATION OF THE HEALTH AND SAFETY GUIDELINES IN SELECTED BUDGET HOTELS IN THE NEW NORMAL

*Kristine joy Castro
Mary Grace C. Santos
Moresa Joy Gregana*

INTRODUCTION

When it comes to the hospitality sector, safety is of utmost importance. The hotel industry has to comply with health and safety regulations. Safety plays an important role in compliance inside the workplace. Safety is one of the most critical aspects that the organizations in a workplace mandatorily obey. Adherence to good health and safety practices and compliance with applicable health and safety regulations is the responsibility for all staff, employees, and guests. The responsibility for safety practices begins with the supervisor in the workplace proceeds upward through the levels of management. Health and Safety in the workplace are important prerequisites for motivated and productive working processes, both for the supervisors, and employees, and management. Health and Safety Guidelines play a big role in this day. Everyone is concerned about their safety wherever they go. This is one of the most important facets of a hotel's reputation. Now that we are entering the New Normal, hotels around the country have imposed safety protocols to make sure we are staying safe and healthy amidst our stay. It becomes our responsibility, therefore, to follow the new norms. All this is to ensure that they will have a pleasant experience during their stay.

The guidelines must be followed before entering inside the Hotels and must comply mandatorily guests must be screened before entry in the Accommodation Establishment through Body temperature check using a Thermal Scanner or Thermometer Gun then completion of Health Declaration and Contact Tracing Form. Cashless/online modes of payment using payment applications or online transactions shall be utilized by the Accommodation Establishment for reservations or bookings. Suppose online, or mobile payment is not possible, in that case, Accommodation Establishments shall create a method for no-contact payment schemes, such as receiving cash on a small tray or leather bill folder to avoid mutual hand contact with customers. Guests shall be advised to disinfect their shoes using sanitizing mats and drying pads provided at the entrances. Physical Distancing measures, hand hygiene, respiratory etiquette, and contactless greeting must be observed when handling guests at the check-in counter. A box or container intended for putting used key cards upon guest check-out shall be provided at the front desk. Express check-out systems shall also be implemented, where possible. Guest services technologies are highly encouraged to minimize guests going to the front desk or concierge to request assistance. Guests must be provided with appropriate information on the prevailing disease and the policies enforced by the establishment to reduce the risk and spread of the disease. Lastly, information materials on hand washing and respiratory etiquette, proper use of face masks, emergency contact numbers, among others, must be provided to guests. These must be followed by budget hotels for the safety of both guests and employees.

Implementing the Health and Safety Guidelines of the Hotels in Crest Hotel, Spring Hotel, and The Malate Pensionne Hotel in Quezon City and Manila. These Hotels are providing basic standard guidelines or protocols have imposed by supervisors and employees. Also, the management to meet an important role in keeping the areas clean and safe for the health of the employees and guests.

The researchers aim to conduct this study to determine the Implementation of the Health and Safety Guidelines in Selected Budget Hotel in the New Normal and the problems

encountered, and be able to come up with viable inputs that can be used to improve the implementation.

METHODOLOGY

This study utilized descriptive types of research methods such as questionnaires and interviews to gather information from groups of subjects. It refers to the overall strategy that we choose to integrate the different components of the study coherently and logically, thereby ensuring you will effectively address the research problem; it constitutes the blueprint for the collecting, measuring, and analyzing data. A survey measures the opinions towards the Implementation of the Health and Safety Guidelines in Selected Budget Hotels in the New Normal.

Moreover, the Descriptive research method emphasizes what kind of question to be asked in the research study. Descriptive research provides the answer to the “what” part of a research and does not answer why/when/how. (Bhasin, 2019) This research design has significance to this study because this design can help the researchers describe and elaborate on the data that will gather in this study.

The population of the study comprises which (50) respondents that participated in the research. The respondents were the (40) employees and (10) supervisors. Researchers used purposive sampling in the selection of the respondents. It is a non-probability sample that is selected based on the characteristics of a population and the objective of the study and when they want to access a particular subset of people, as all participants of a study are selected because they fit a particular profile. (Crossman, 2020) This type of sampling method also known as judgement sampling, inquires the researchers to have prior knowledge about the purpose of their studies so that they can properly choose and approach eligible participants using their expertise to select a sample that is most useful to the purposes of the research.

RESULTS AND DISCUSSION

Sub-problem No. 1: How do the respondents assess the Implementation of the Health and Safety Guidelines in Selected Budget Hotel in the New Normal?

As revealed in Table 1, the employees' Temperature check-screening for both employees and guests with a weighted mean of 4.88 with a verbal interpretation of Highly Implemented, Provision of basic sanitation kit in all offices. There are available disposable face mask and face shields for the use of employees with a weighted mean of 4.83, A health declaration Form must be filled up prior to check-in for contact tracing purposes with a weighted mean of 4.80, Disinfection of rooms every after guests check out with a weighted mean of 4.80, Toilets and restroom are sanitized every now and then, even when not in use with a weighted mean of 4.80, Physical distancing, hand hygiene and respiratory etiquette with a weighted mean of 4.78, Floor markers for 1-meter social distancing in any counters with a weighted mean of 4.75, Provision of alcohol-based disinfectants at the entrance of the hotel and elevators, and all the floor level with a weighted mean of 4.75, All rooms are properly disinfected before releasing to the guest and marked accordingly for the guest to see that it was disinfected with a weighted mean of 4.75, If the room was used by a suspected infected person, all washable items are placed in a separate disposal bag and wash separately using hot water (70- 80 degrees C)with a weighted mean of 4.75, Wearing of facemasks and face shield when in public spaces for employees and guests with a weighted mean of 4.73, Guest must provide their emergency contact numbers with a weighted mean of 4.73, Reduce seating capacity per table by 50% in public and private dining areas with a weighted mean of 4.73,

Table 1
Implementation of the Health and Safety Guidelines

Indicators	Employees		Supervisors		Composite		Rank
	WM	VI	WM	VI	WM	VI	
1. A health declaration Form must be filled up prior to check-in for contact tracing purposes.	4.80	HI	5.00	HI	4.90	HI	3.33
2. Wearing of facemasks and face shield when in public spaces for employees and guests.	4.73	HI	5.00	HI	4.87	HI	9.44
3. Temperature check-screening for both employees and guests.	4.88	HI	5.00	HI	4.94	HI	1
4. Floor markers for 1-meter social distancing in any counters.	4.75	HI	4.90	HI	4.83	HI	16.5
5. Provision of reminder cards on the prevailing disease, and policies enforced by the establishment.	4.70	HI	4.80	HI	4.75	HI	21
6. Physical distancing, hand hygiene and respiratory etiquette.	4.78	HI	5.00	HI	4.89	HI	6
7. No loitering of guests in the hallways.	4.50	HI	4.80	HI	4.65	HI	24
8. Contactless transaction is highly encouraged, including but not limited to check-in and check-out.	4.48	HI	4.60	HI	4.54	HI	25
9. Guest must provide their emergency contact numbers.	4.73	HI	5.00	HI	4.87	HI	9.44
10. Provision of alcohol-based disinfectants at the entrance of the hotel and elevators, and all the floor Levels.	4.75	HI	4.80	HI	4.78	HI	19
11. All rooms are properly disinfected before releasing to the guest and marked accordingly for the guest to see that it was disinfected.	4.75	HI	5.00	HI	4.88	HP	7.5
12. Washable items must be soaked using the appropriate disinfecting solution for at least 15 minutes.	4.65	HI	4.80	HI	4.73	HI	22
13. Provision of basic sanitation kit in all offices. There are available disposable face masks and face shields for the use of employees.	4.83	HI	5.00	HI	4.92	HI	2
14. Disinfection of rooms every after guests check out.	4.80	HI	5.00	HI	4.90	HI	3.33
15. All items for disposal must be disposed of in sealed bags immediately.	4.68	HI	5.00	HI	4.84	HI	13.33
16. If the room was used by a suspected infected person, all washable items are placed in a separate disposal bag and wash separately using hot water (70- 80 degrees C).	4.75	HI	5.00	HI	4.88	HI	7.5
17. Only single up to double room occupancy is allowed.	4.53	HI	5.00	HI	4.77	HI	20
18. All work areas are regularly sanitized.	4.70	HI	4.90	HI	4.80	HI	18
19. Reduce seating capacity per table by 50% in public and private dining areas.	4.73	HI	5.00	HI	4.87	HI	9.44
20. Disinfection of function venues during break time or after every meeting/event.	4.68	HI	5.00	HI	4.84	HI	13.33
21. Limit elevator Capacity based on distance.	4.33	HI	5.00	HI	4.67	HI	23
22. Trash bins are emptied regularly and dispose to proper disposal and bins are sanitized accordingly.	4.65	HI	5.00	HI	4.83	HI	16.5
23. Toilets and restrooms are sanitized every now and then, even when not in use.	4.80	HI	5.00	HI	4.90	HI	3.33
24. Hand sanitizing agents are available at the toilets room.	4.73	HI	5.00	HI	4.87	HI	9.44
25. Employees are working on a skeletal workforce.	4.68	HI	5.00	HI	4.84	HI	13.33
Overall Weighted Mean	4.69	HI	4.94	HI	4.82	HI	

Hand sanitizing agents are available at the toilets room with a weighted mean of 4.73, Provision of reminder cards on the prevailing disease, and policies enforced by the establishment with a weighted mean of 4.70, All work areas are regularly sanitized with a weighted mean of 4.70, All items for disposal must be disposed in sealed bags immediately with a weighted mean of 4.68, Disinfection of function venues during break time or after every meeting / event with a weighted mean of 4.68, Employees are working on skeletal workforce with a weighted mean of 4.68, Washable items must be soaked using appropriate disinfecting solution for at least 15 minutes with a weighted mean of 4.65, Trash bins are emptied regularly and dispose to proper disposal and bins are sanitized accordingly with a weighted mean of 4.65, Only single up to double room occupancy is allowed with a weighted mean of 4.53, No loitering of guests in the hallways with a weighted mean of 4.50, Contactless transaction is highly encouraged, including but not limited to check-in and check-out with a weighted mean of 4.48, Limit elevator capacity based on distancing with a weighted mean of 4.33. All the twenty-five items were verbally interpreted as Highly Implemented.

As to supervisors, A health declaration Form must be filled up prior to check-in for contact tracing purposes with a weighted mean of 5.00 with a verbal interpretation of Highly Implemented, Wearing of facemasks and face shield when in public spaces for employees and guests with a weighted mean of 5.00, Temperature check-screening for both employees and guests with a weighted mean of 5.00, Physical distancing, hand hygiene and respiratory etiquette with a weighted mean of 5.00, Guest must provide their emergency contact numbers with a weighted mean of 5.00, All rooms are properly disinfected before releasing to the guest and marked accordingly for the guest to see that it was disinfected with a weighted mean of 5.00, Provision of basic sanitation kit in all offices. There are available disposable face mask and face shields for the use of employees with a weighted mean of 5.00, Disinfection of rooms every after guests check out with a weighted mean of 5.00, All items for disposal must be disposed in sealed bags immediately with a weighted mean of 5.00, If the room was used by a suspected infected person, all washable items are placed in a separate disposal bag and wash separately using hot water (70- 80 degrees C) with a weighted mean of 5.00, Only single up to double room occupancy is allowed with a weighted mean of 5.00, Reduce seating capacity per table by 50% in public and private dining areas with a weighted mean of 5.00, Disinfection of function venues during break time or after every meeting / event with a weighted mean of 5.00, Limit elevator capacity based on distancing with a weighted mean of 5.00, Trash bins are emptied regularly and dispose to proper disposal and bins are sanitized accordingly with a weighted mean of 5.00, Toilets and restroom are sanitized every now and then, even when not in use with a weighted mean of 5.00, Hand sanitizing agents are available at the toilets room with a weighted mean of 5.00, Employees are working on skeletal workforce with a weighted mean of 5.00, Floor markers for 1-meter social distancing in any counters with a weighted mean of 4.90, All work areas are regularly sanitized with a weighted mean of 4.90, Provision of reminder cards on the prevailing disease, and policies enforced by the establishment with a weighted mean of 4.80, No loitering of guests in the hallways with a weighted mean 4.80, Provision of alcohol-based disinfectants at the entrance of the hotel and elevators, and all the floor level with a weighted mean of 4.80, Washable items must be soaked using appropriate disinfecting solution for at least 15 minutes with a weighted mean of 4.80, Contactless transaction is highly encouraged, including but not limited to check-in and check-out with a weighted mean of 4.60. All the twenty-five items were verbally interpreted as Highly Implemented.

Generally, the assessment on the implementation of the health and safety guidelines in selected budget hotels in the new normal rated as Highly Implemented with an overall weighted mean of 4.82. All items rated as Highly Implemented, namely: temperature check-screening for both employees and guests with a composite weighted mean of 4.94 as rank 1; provision of

basic sanitation kit in all offices. There are available disposable face mask and face shields for the use of employees with composite weighted mean of 4.92 as rank 2; a health declaration Form must be filled up prior to check-in for contact tracing purposes; disinfection of rooms every after guests check out; and toilets and restroom are sanitized every now and then, even when not in use with similar composite weighted mean of 4.90 as rank 3, 4, and 5; physical distancing, hand hygiene, and respiratory etiquette with composite weighted mean of 4.89 as rank 6; all rooms are properly disinfected before releasing to the guest and marked accordingly for the guest to see that it was disinfected; and if the room was used by a suspected infected person, all washable items are placed in a separate disposal bag and wash separately using hot water (70- 80 degrees C) with both composite weighted mean of 4.88 as rank 7 and 8; wearing of facemasks and face shield when in public spaces for employees and guests; Guest must provide their emergency contact numbers ;reduce seating capacity per table by 50% in public and private dining areas; and Hand sanitizing agents are available at the toilets room. with both composite weighted mean of 4.87 as rank 9,10,11, and 12; all items for disposal must be disposed in sealed bags immediately; Disinfection of function venues during break time or after every meeting / event; and Employees are working on skeletal workforce with composite weighted mean of 4.84 as rank 13,14, and 15;floor markers for 1-meter social distancing in any counters; and Trash bins are emptied regularly and dispose to proper disposal and bins are sanitized accordingly with both composite weighted mean of 4.83 as rank 16 and 17; all work areas are regularly sanitized with composite weighted mean of 4.80 as rank 18; Provision of alcohol-based disinfectants at the entrance of the hotel and elevators, and all the floor level with composite weighted mean of 4.78 as rank 19; Only single up to double room occupancy is allowed with composite weighted mean of 4.77 as rank 20; Provision of reminder cards on the prevailing disease, and policies enforced by the establishment with composite weighted mean of 4.75 as rank 21; washable items must be soaked using appropriate disinfecting solution for at least 15 minutes with composite weighted mean of 4.73 as rank 22; Limit elevator capacity based on distancing with composite weighted mean of 4.67 as rank 23; No loitering of guests in the hallways composite weighted mean of 4.65 as rank 24; Contactless transaction is highly encouraged, including but not limited to check-in and check-out with composite weighted mean of 4.54 as rank 25.

Sub-problem No. 2: Is there any significant difference in the assessment of the two groups of respondents on the Implementation of Health and Safety Guidelines?

Table 2
Comparative Assessment on the Implementation of the Health and Safety Guidelines

Employees		Supervisors		Df	t-value	critical value	Decision	Interpretation
WM	SD	WM	SD					
4.69	0.0151	4.94	0.0233	48	0.613015	1.684	Accept Ho	Not Significant

As depicted in Table 2, the computed t-value is 0.613015 which is lower than the critical value of 1.684 with 48 degree of freedom at 0.05 level of significance. Hence, there is no significant difference on the Implementation on Health and Safety Guidelines as assessed by employees and supervisors. Therefore, the hypothesis is accepted.

Sub-problem No. 3: What are the problems encountered by the respondents?

Table 3
Problems Encountered on the Implementation of the Health and Safety Guidelines.

Indicators	Employees		Supervisors		Composite		Rank
	WM	VI	WM	VI	WM	VI	
1. Limited hand sanitizing agents at the toilets room.	2.55	LE	2.70	ME	2.63	ME	1
2. Reduced seating capacities per table are sometimes not followed.	2.55	LE	2.40	LE	2.48	LE	3
3. Difficult to determine if the room was used by a suspected infected person.	2.30	LE	2.20	LE	2.25	LE	9.5
4. Not enough staff to work on areas that need to be sanitized.	2.55	LE	2.50	LE	2.53	ME	2
5. Unable to sanitize the toilet rooms regularly due to limited manpower.	2.43	LE	2.30	LE	2.37	LE	6
6. Limited basic sanitation kit in all offices. There are not enough available disposable face masks and face shields for the use of employees.	2.35	LE	2.40	LE	2.38	LE	5
7. Some guests are loitering in the hallways.	2.40	LE	2.30	LE	2.35	LE	7
8. Physical distancing is not followed.	2.38	LE	2.50	LE	2.44	LE	4
9. Counters have been properly marked from distancing.	2.23	LE	1.90	LE	2.07	LE	12.5
10. Cleaning and disinfecting of hotel rooms are done in a hurry.	2.15	LE	1.90	LE	2.03	LE	14
11. Compliance with the safety measures and procedures as to wearing a face mask and face shields.	2.23	LE	1.90	LE	2.07	LE	12.5
12. Non-declaration of correct information in the contact tracing form by the guests.	2.23	LE	2.20	LE	2.22	LE	11
13. Some guest violates the single room occupancy policy.	2.30	LE	2.20	LE	2.25	LE	9.5
14. Elevator reduced capacity limit is not followed.	2.35	LE	2.30	LE	2.33	LE	8
15. Temperature screenings are not done to all employees and guests.	2.10	LE	1.80	LE	1.95	LE	15
Overall Weighted Mean	2.34	LE	2.23	LE	2.29	LE	

As exposed in Table 3, the employees Hand sanitizing agents are very limited at the toilets room with a weighted mean of 2.55 with a verbal interpretation of Least Encountered, Reduced seating capacity per table are sometimes not followed with a weighted mean of 2.55, Not enough staff to work on areas that need to be sanitized with a weighted mean of 2.55, Unable to sanitized the toilet rooms regularly due to limited manpower. with a weighted mean of 2.43, Some guests are loitering in the hallways with a weighted mean of 2.40, Physical distancing is not followed with a weighted mean of 2.38, Limited basic sanitation kit in all offices. There is not enough available disposable face mask and face shields for the use of employees with a weighted mean of 2.35, Elevator reduced capacity limit is not followed with a

weighted mean of 2.35, Difficult to determine if the room was used by a suspected infected person with a weighted mean of 2.30, Some guest violates the single room occupancy policy with a weighted mean of 2.30, Counters have been properly marked from distancing with a weighted mean of 2.23, Non-compliance of the safety measures and procedures as to wearing a face mask and face shields with a weighted mean of 2.23, Non-declaration of correct information in the contact tracing form by the guests with a weighted mean of 2.23, Cleaning and disinfecting of hotel rooms are done in a hurry with a weighted mean of 2.15, Temperature screening are not done to all employees and guests with a weighted mean of 2.10. All the fifteen items were verbally interpreted as Least Encountered.

As to supervisors, Hand sanitizing agents are very limited at the toilets room with a weighted mean of 2.70 with a verbal interpretation of Moderately encountered, Number of staff are not enough to work on areas that need to be sanitized with a weighted mean of 2.50, Physical distancing is not followed with a weighted mean of 2.50, Reduced seating capacity per table are sometimes not followed with a weighted mean of 2.40, Limited basic sanitation kit in all offices. There are not enough available disposable face mask and face shields for the use of employees with a weighted mean of 2.40, Toilets and restroom are not regularly sanitized due to limited manpower with a weighted mean of 2.30, Some guests are loitering in the hallways with a weighted mean of 2.30, Elevator reduced capacity limit is not followed with a weighted mean of 2.30, No qualified employee to determine if the room was used by a suspected infected person with a weighted mean of 2.20, Non-declaration of correct information in the contact tracing form by the guests with a weighted mean of 2.20, Some guest violates the single up to double room occupancy policy with a weighted mean of 2.20, Not all counters have been properly marked from distancing with a weighted mean of 1.90, Improper cleaning and disinfecting of hotel rooms / done in a hurry with a weighted mean of 1.90, Non-compliance of the safety measures and procedures as to wearing face mask and face shields with a weighted mean of 1.90, Temperature screening are not done to all employees and guests with a weighted mean of 1.80. One item was verbally interpreted as Moderately Encountered and fourteen items were verbally interpreted as Least Encountered.

Summarily, the assessment on the problems encountered on the implementation on health and safety guidelines in selected budget hotels in the new normal rated as Least Encountered with an overall weighted mean of 2.29. Two (2) items rated as Moderately Encountered, these are: hand sanitizing agents are very limited at the toilets room with a composite weighted mean of 2.63 as rank 1, and numbers of staffs are not enough to work on areas that need to be sanitized with a composite weighted mean of 2.53 as rank 2. Thirteen (13) items rated as Least Encountered, namely: reduced seating capacity per table are sometimes not followed with a composite weighted mean of 2.48 as rank 3; physical distancing is not followed with a composite weighted mean of 2.44 as rank 4; limited basic sanitation kit in all offices. There are not enough available disposable face mask and face shields for the use of employees with composite weighted mean of 2.38 as rank 5; toilets and restroom are not regularly sanitized due to limited manpower with composite weighted mean of 2.37 as rank 6; some guests are loitering in the hallways with composite weighted mean of 2.35 as rank 7; elevator reduced capacity limit is not followed with composite weighted mean of 2.33 as rank 8; no qualified employee to determine if the room was used by a suspected infected person; and some guest violates the single up to double room occupancy policy with both composite weighted mean of 9 and 10; non-declaration of correct information in the contact tracing form by the guests with composite weighted mean of 2.22 as rank 11; not all counters have been properly marked from distancing; and non-compliance of the safety measures and procedures as to wearing face mask and face shields with both composite weighted mean of 2.07 as rank 12 and 13; improper cleaning and disinfecting of hotel rooms / done in a hurry with composite weighted mean of 2.03 as rank 14; and temperature screening are not done to all employees and guests with composite weighted mean of 1.95 as rank 15.

CONCLUSIONS AND RECOMMENDATIONS

Based on the findings of the study, the following are conclusions of the study are hereby drawn:

1. The Implementation of the Health and Safety Guidelines in Selected Budget Hotels in the New Normal is very much enforced as assessed by the respondents.
2. The two groups of respondents share a similar assessment on the Implementation of the Health and Safety Guidelines in the New Normal.
3. There are very few issues met by the respondents on the Implementation of the Health and Safety Guidelines in Selected Budget Hotels in the New Normal.

Based on the findings and conclusions of the study, the following recommendations are suggested:

1. The supervisors and the employees of the Crest Hotel, Spring Hotel, and Malate Pensionne Hotel must continue to strengthen the implementation of the Health and Safety Guidelines in the New Normal to attain the full extent of enforcing the required health and safety protocols.
2. Both the supervisors and employees also the management ought to implement and maintain some areas that they can explore to strengthen the implemented health and Safety Guidelines in the New Normal.
3. On the problems that are almost not experience, the following are suggested; Ensure provision of enough hand sanitizing agents at the toilet rooms all the time, assign a person who will be responsible for sanitation of all work areas, strictly enforce the prescribed seating capacities per table by removing any extra chairs, all other concerns that are so minute, such as loitering at the hallways, basic sanitation kits, wearing of face masks and face shields, and capacity of elevators, should be enforced strictly to avoid any lapses that might endanger anyone.
4. Similar research may be conducted in the future to verify the validity of the results of this study.

REFERENCES

- Rajini, D. (2018). "Preventive Methods used for Health and Safety Hazards in Hotel Industry in Sri Lanka", Colombo Sri Lanka.
- Chauhan, A. Shukla, A. & Negi P. (2018). "Safety and security measures adopted by the hotels and their impact on customer relationship management". International journal research. Tehri, India.
- Ghazi, K. M. (2015). "Safety and Security Measures in Egyptian Hotels". Associations of Arab University.
- Humarang, J. (2020). OYO Hotels & Homes PH rolls out 'Sanitized Stays' for Covid-19 protection. Retrieved from: <http://techandlifestylejournal.com/oyo-hotels-sanitized-stays-ph/>
- Rocamora, J. (2020). Nat'l gov't inspects protocol compliance of hotels, resto's in NCR. Retrieved from <https://www.pna.gov.ph/articles/1107709>
- Supetran, B. (2020). Hotels step up COVID-19 measures. Retrieved from <https://business.inquirer.net/293099/hotels-step-up-covid-19-measures>
- Tabios, H. (2020). DOT releases guidelines for hotels, inns under 'new normal'. Retrieved from <https://mb.com.ph/2020/05/26/dot-releases-guidelines-for-hotels-inns-under-new-normal/>
- Tavelera, C. (2020). Hotels are given new guidelines for post- COVID operations. Retrieved from <https://www.philstar.com/business/2020/05/26/2016443/hotels-given-new-guidelines-post-covid-operations>
- Villareal, M. (2020). DOT, DTI Inspect Hotels and Restaurants' Compliance with Health and Safety Protocols. Retrieved from <https://outoftownblog.com/dot-dti-inspect-hotels-and-restaurants-compliance-with-health-and-safety-protocols/>
- Verma, V. (2020). Safety Measures Implemented by Hospitality Sector amidst COVID 19. Retrieved from <https://hospitality.economictimes.indiatimes.com/blog/safety-measures-implemented-by-hospitality-sector-amidst-covid-19/4202>
- Morantis, N. (2019). Safety at Hotels: Key Points that ensure the development of a Hotel's Safety Culture. Retrieved from <https://www.traveldailynews.com/post/safety-at-hotels-key-points-that-ensure-the-development-of-a-hotels-safety-culture>
- Alananzeh, O. (2017). Impact of Safety Issues and Hygiene Perceptions on Costumers Satisfaction a Case Study of Four and Five Star Hotels in Aqaba Jordan. Retrieved from https://www.researchgate.net/publication/314977147_Impact_of_Safety_Issues_and_Hygiene_Perceptions_on_Customer_Satisfaction_A_Case_Study_of_Four_and_Five_Star_Hotels_in_Aqaba_Jordan
- Ashraf, N. (2018). A study that examines Safety Culture, Risk Management and Safety Management in Hospitality Industry. Retrieved from uis.brage.unit.no/uis-xmlui/handle/11250/2563162
- Abishek, R. & Chauhan, A. (2018). Safety and Security Measures Adopted by the Hotels and their Impact on Customer Relationship. Retrieved from granthayaalah.com/Articles/Vol6Iss1/11_IJRG18_A01_1039.Pdf

- Delacruz, K. (2020). Updated Guidelines and Safety Protocols for Staycations in GCQ Areas. Retrieved from <https://www.klook.com/en-PH/blog/safety-health-guidelines-staycation/>
- Guevara, D. (2017). The Occupational Health and Safety System and its Influence on Labor Performance: Hotel Industry Analysis in the City of Ambato. Retrieved from file:///C:/Users/SYSTEM%20UNIT/Downloads/zt783_grthlm_adolfo-ricardo-guaman-450866.pdf
- Kloepple, S. (2020). Hotels and Resorts Are Doing to Enhance Health and Sanitation Standards. Retrieved from <https://www.meetingstoday.com/magazines/article-details/articleid/34317/title/hotels-sanitation-standards>
- Apongol, L. (2020). Hotel Safety Protocols: The New Normal for Hotels in the Philippines. Retrieved from <https://kapwatravel.com/blog/the-new-normal-for-hotels-in-the-philippines/>
- Villareal, M. (2020). Sheraton Manila Bay embraces “New Normal” with enhanced cleaning protocol and safety measures. Retrieved from <https://outoftownblog.com/sheraton-manila-bay-embraces-the-new-normal/>
- Llarena, S. (2020). Safe stay: Hotels prepare for life Post pandemic. Retrieved from <https://manilastandard.net/mobile/article/325828>
- Pendon, L. (2020). The hospitality industry's response to COVID-19. Retrieved from <http://fnbreport.ph/features/hospitality/the-hospitality-industry's-response-to-covid-19-lylep-20200520/>
- Malaya, B. (2020). Variables. Retrieved from <https://www.whatalife.ph/dot-health-guidelines-for-accommodation-establishments>
- Mcgrath, R. (2020). Face Mask. Retrieved from <https://www.merriam-webster.com/dictionary/face%20mask?fbclid=IwAR3Kul84xecp2QMsCCMypolkpxvUJAP4aJk1eIGozEsaxnQt7RYPqiOEhjj>
- The University of Tennessee Knoxville. (2020). Face Shield. Retrieved from <https://ehs.utk.edu/index.php/covid-19-workplace-safety-guidelines/face-shields/>
- HSE- Health and Safety Executive. (2020). Personal Protective Equipment/PPE. Retrieved from <https://www.hse.gov.uk/toolbox/ppe.htm>
- World Health Organizations/ WHO - Scientific Brief. (2020). Rapid Test. Retrieved from [https://www.who.int/news-room/commentaries/detail/advice-on-the-use-of-point-of-care-immunodiagnostic-testsforcovid19#:~:text=Rapid%20diagnostic%20tests%20\(RDT,typically%20within%2030%20minutes](https://www.who.int/news-room/commentaries/detail/advice-on-the-use-of-point-of-care-immunodiagnostic-testsforcovid19#:~:text=Rapid%20diagnostic%20tests%20(RDT,typically%20within%2030%20minutes)

PERSONNEL POLICIES IN MANILA TRAFFIC AND PARKING BUREAU OF THE CITY GOVERNMENT OF MANILA: AN ASSESSMENT

*Diana P. Dela Cruz
Erick P. Mante*

INTRODUCTION

A systemized and equitable personnel policy is the most valuable asset that any government management can have. The organization's planned actions are based on policies established by the top management.

Personnel policies are one of the most important aspects of public personnel administration in order to create and maintain a satisfactory employer-employee relationship. Personnel policies are management tools that give life and direction to the progression of activities and establish the boundaries within which action is to be pursued by the personnel involved. They provide definite guidelines for consistent treatment of employees.

Activities such as recruitment, selection, compensation, training, appraisal, rewards and discipline are the responsibility of the public personnel administrators. The phenomenal expansion of the government's functions and responsibilities increased the size of its workforce, making the government the world's largest employer. In the Philippines, the scope of government activities in relation to its workplace began at the national level and gradually spread to the local level as local government units began delivering evolved and new programs and services. Local government units, which were established to assist national governments in administering diverse territories and raising revenues, have enormous potential for defining local needs and conditions. They function as a dynamic mechanism for delivering basic services and governing the people who live within territorial jurisdiction. Moreover, local government units should take a closer and serious look at various public personnel administration functions that they need to pursue in their way to development. One of these developments has something to do with traffic in the city, which is where the Manila Traffic and Parking Bureau (MTPB) comes into play in the City Government of Manila. The implementation of personnel policies at the local level is an important component in the achievement of personnel administration's goals and objectives. Personnel policies are one of the primary tools used by local government units to carry out their functions; any neglect or improper management can result in inefficiency.

MATERIALS AND METHOD

This research utilized the quantitative research methodology. The instruments used to collect data was the observational instruments, which is set of questionnaires containing the effectiveness of the implementation of personnel policies in the Manila Traffic and Parking Bureau in the City Government of Manila. This information will be much helpful in conducting a precise quantitative raw data analyzed according to the feedbacks gathered from respondents.

The selected respondents are personnel from the Manila Traffic and Parking Bureau. Respondents were those who were permanent, casual and job order employment status. The respondents were chosen on the basis of their knowledge to supply information required in the questionnaire.

The following instruments in gathering data used in this research were weighted mean, ranking and t-test were tabulated, analyzed and interpreted.

RESULTS AND DISCUSSIONS

Sub-problem No. 1. What is the extent of implementation of the personnel policies in Manila Traffic and Parking Bureau on the following areas:

1. Recruitment and Selection

Table 1 shows the extent of implementation of the personnel policies as to recruitment and selection.

Table 1
Extent of Implementation as to Recruitment and Selection

Criteria	WM	VI	Rank
1. All qualified citizens have the opportunity to work for the government, and good efforts are made to attract the most qualified persons to join the service.	3.43	M	4
2. Qualified applicants are required to fill up application form, written examinations, interviews, physical examination, experience and references, etc.	3.56	E	3
3. Selection among eligible is done in accordance to skills, educational background and experience.	3.66	E	1
4. Employees are chosen based on their ability to perform the duties and responsibilities of the position.	3.61	E	2
Overall Weighted Mean	3.56	E	

Legend:

4.50 – 5.00	Very Extensive	(VE)
3.50 – 4.49	Extensive	(E)
2.50 – 3.49	Moderate	(M)
1.50 – 2.49	Barely	(B)
1.00 – 1.49	Not Extensive	(NE)

As shown in the table, the respondents observed item 3 – selection among eligible is done in accordance to skills, educational background and experience was rated 3.66 interpreted as “extensive” and ranked 1; item 4 – employees are chosen based on their ability to perform the duties and responsibilities of the position was rated 3.61 interpreted as “extensive” and ranked 2; item 2 – qualified applicants are required to fill up application form, written examinations, interviews, physical examination, experience and references, etc. was rated 3.56 interpreted as “extensive” and ranked 3; and item 1 – all qualified citizens have the opportunity to work for the government, and good efforts are made to attract the most qualified persons to join the service was rated 3.43 interpreted as “moderate” and ranked 4, respectively.

It can be gleaned from the data that the extent of implementation of the personnel policies as to recruitment and selection was rated by the respondents with an overall weighted mean of 3.56 interpreted as “extensive.”

2. Compensation and Benefits

Table 2 depicts the extent of implementation of the personnel policies as to compensation and benefits.

As depicted in the table, the respondents observed item 3 – the compensation is allocated to a certain salary grade depending on the position title was rated 3.74 interpreted as “extensive” and ranked 1; item 2 – equal pay for equal work is implemented, such that government employees receive just and equitable wages was rated 3.59 interpreted as “extensive” and ranked 2; and item 1 – the compensation of the local government personnel is tied to the classification and the position classification act of 1989 was rated 3.50 interpreted as “extensive” and ranked 3, respectively.

Table 2
Extent of Implementation as to Compensation and Benefits

Criteria	WM	VI	Rank
1. The compensation of the local government personnel is tied to the classification and the position classification act of 1989.	3.50	E	3
2. Equal pay for equal work is implemented, such that government employees receive just and equitable wages.	3.59	E	2
3. The compensation is allocated to a certain salary grade depending on the position title.	3.74	E	1
Overall Weighted Mean	3.61	E	

It can be noted from the data that the extent of implementation of the personnel policies as to compensation and benefits was rated by the respondents with an overall weighted mean of 3.61 interpreted as “extensive.”

3. Training and Development

Table 3 reflects the extent of implementation of the personnel policies as to training and development.

Table 3
Extent of Implementation as to Training and Development

Criteria	WM	VI	Rank
1. Training plans apply to both the individual and the organization.	3.55	E	4
2. The training plans specify the nature and scope of job training for basic operation.	3.79	E	1
3. Employees are given the opportunities to design learning plans to meet their own unique needs.	3.58	E	3
4. The department plans, manages, and promotes a systematic plan of action for employee training at all levels in conformity with rules and laws.	3.73	E	2
Overall Weighted Mean	3.66	E	

As reflected in the table, the respondents observed item 2 – the training plans specify the nature and scope of job training for basic operation was rated 3.79 interpreted as “extensive” and ranked 1; item 4 – the department plans, manages, and promotes a systematic plan of action for employee training at all levels in conformity with rules and laws was rated 3.73 interpreted as “extensive” and ranked 2; item 3 – employees are given the opportunities to design learning plans to meet their own unique needs was rated 3.58 interpreted as “extensive” and ranked 3; and item 1 – training plans apply to both the individual and the organization was rated 3.55 interpreted as “extensive” and ranked 4, respectively.

It can be noted from the data that the extent of implementation of the personnel policies as to training and development was rated by the respondents with an overall weighted mean of 3.66 interpreted as “extensive.”

4. Performance Appraisal

Table 4 reveals the extent of implementation of the personnel policies as to performance appraisal.

Table 4
Extent of Implementation as to Performance Appraisal

Criteria	WM	VI	Rank
1. There is a performance evaluation system that is governed by rules, regulations, and standards.	3.66	E	2
2. The performance evaluation system is implemented in such a way that it continuously promotes the improvement of individual employment efficiency and organizational effectiveness.	3.69	E	1
3. Performance evaluation plans are used, depending on the various categories of positions in the department.	3.64	E	3
Overall Weighted Mean	3.66	E	

As revealed in the table, the respondents observed item 2 – the performance evaluation system is implemented in such a way that it continuously promotes the improvement of individual employment efficiency and organizational effectiveness was rated 3.69 interpreted as “extensive” and ranked 1; item 1 – there is a performance evaluation system that is governed by rules, regulations, and standards was rated 3.66 interpreted as “extensive” and ranked 2; and item 3 – performance evaluation plans are used, depending on the various categories of positions in the department was rated 3.64 interpreted as “extensive” and ranked 3, respectively.

It can be noted from the data that the extent of implementation of the personnel policies as to performance appraisal was rated by the respondents with an overall weighted mean of 3.66 interpreted as “extensive.”

5. Incentives and Rewards System

Table 5 depicts the extent of implementation of the personnel policies as to incentives and rewards system.

Table 5
Extent of Implementation as to Incentives and Rewards System

Criteria	WM	VI	Rank
1. Employee ideas and incentive rewards are conducted through a government-wide system that is governed by laws, regulations, and standards.	3.55	E	4
2. Incentives and awards are granted to those who exceed their targets efficiency and organizational effectiveness.	3.81	E	1
3. Incentives and awards are offered to those who have exhibited excellent service on the basis of their adherence to norms of conduct.	3.61	E	3
4. Consistently provide incentives to officers and employees for professional advancement, and promote the career system in government service.	3.74	E	2
Overall Weighted Mean	3.68	E	

As depicted in the table, the respondents observed item 2 – incentives and awards are granted to those who exceed their targets efficiency and organizational effectiveness was rated 3.81 interpreted as “extensive” and ranked 1; item 4 – consistently provide incentives to officers and employees for professional advancement, and promote the career system in government service was rated 3.74 interpreted as “extensive” and ranked 2; item 3 – incentives and awards are offered to those who have exhibited excellent service on the basis of their adherence to norms of conduct was rated 3.61 interpreted as “extensive” and ranked 3; and item 1 – employee ideas and incentive rewards are conducted through a government-wide system that is governed by laws, regulations, and standards was rated 3.55 interpreted as “extensive” and ranked 4, respectively.

It can be noted from the data that the extent of implementation of the personnel policies as to incentives and reward system was rated by the respondents with an overall weighted mean of 3.68 interpreted as “extensive.”

6. Discipline

Table 6 reflects the extent of implementation of the personnel policies as to discipline.

Table 6
Extent of Implementation as to Discipline

Criteria	WM	VI	Rank
1. A ground for disciplinary action is done with accordance to the code, civil service rules, laws and other formulations.	3.70	E	3
2. No officer or employee is suspended or dismissed unless there is a legal reason and due process has been followed.	3.71	E	2
3. Local chief executive may issue preventive suspension to any local personnel.	3.69	E	4
4. Local chief executive may impose sanction erring personnel depending upon gravity of the offense and the circumstances surrounding the case.	3.79	E	1
Overall Weighted Mean	3.72	E	

As reflected in the table, the respondents observed item 4 – local chief executive may impose sanction erring personnel depending upon gravity of the offense and the circumstances surrounding the case was rated 3.79 interpreted as “extensive” and ranked 1; item 2 – no officer or employee is suspended or dismissed unless there is a legal reason and due process has been followed was rated 3.71 interpreted as “extensive” and ranked 2; item 1 – a ground for disciplinary action is done with accordance to the code, civil service rules, laws and other formulations was rated 3.70 interpreted as “extensive” and ranked 3; and item 3 – local chief executive may issue preventive suspension to any local personnel was rated 3.69 interpreted as “extensive” and ranked 4, respectively.

It can be noted from the data that the extent of implementation of the personnel policies as to discipline was rated by the respondents with an overall weighted mean of 3.72 interpreted as “extensive.”

Table 7 presents the summary of the overall mean of the respondent’s perception on the extent of implementation of the personnel policies in Manila Traffic and Parking Bureau.

Table 7
Summary of Assessment on the Extent of Implementation

Indicators	WM	VI	Rank
1. Recruitment and Selection	3.57	E	6
2. Compensation and Benefits	3.61	E	5
3. Training and Development	3.66	E	3.5
4. Performance Appraisal	3.66	E	3.5
5. Incentives and Reward System	3.68	E	2
6. Discipline	3.72	E	1
Overall Grand Mean	3.65	E	

As presented in the table, ranked 1 was discipline with an overall weighted mean of 3.72. Moreover, incentives and reward system ranked 2 with an overall weighted mean of 3.68. Performance appraisal, and training and development both ranked 3.5 with an overall weighted mean of 3.66. Next was compensation and benefits ranked 5 with an overall weighted mean of 3.61. Followed by recruitment and selection with an overall weighted mean of 3.57 and ranked 6. All of these variables are verbally interpreted as “extensive” with an overall grand mean of 3.65.

Sub-problem No. 2. Is there a significant difference in the assessment of the respondents on the aforementioned variables?

To determine if significant difference exists among the assessment of the respondents, the t-test was used. The results of the application of the t-test as shown in the statistical matrix in table 8 reveals the following results on the extent of:

Table 8
Significant Difference in the extent of Implementation of the Personnel Policies

Indicators	Computed t-value	df	t-Critical Value	Standard Deviation	Interpretation	Decision
Recruitment and Selection	72.15	3	2.35	.099	Significant	Reject Ho
Compensation and Benefits	51.57	2	2.92	.121	Significant	Reject Ho
Training and Development	63.22	3	2.35	.116	Significant	Reject Ho
Performance Appraisal	252.13	2	2.92	.025	Significant	Reject Ho
Incentives and Reward System	61.96	3	2.35	.119	Significant	Reject Ho
Discipline	162.79	3	2.35	.046	Significant	Reject Ho

Legend:

df = degrees of freedom

As to recruitment and selection, the obtained t-value was 72.15 which is greater than the t-critical value of 2.35 at .05 level of significance. Hence, there is a significant difference on the extent of implementation of the personnel policies and therefore this leads to the rejection of the hypothesis.

As to compensation and benefits, the obtained t-value was 51.57 which is greater than the t-critical value of 2.92 at .05 level of significance. Hence, there is a significant difference on the extent of implementation of the personnel policies and therefore this leads to the rejection of the hypothesis.

As to training and development, the obtained t-value was 63.22 which is greater than the t-critical value of 2.35 at .05 level of significance. Hence, there is a significant difference on the extent of implementation of the personnel policies and therefore this leads to the rejection of the hypothesis.

As to performance appraisal, the obtained t-value was 252.13 which is greater than the t-critical value of 2.92 at .05 level of significance. Hence, there is a significant difference on the extent of implementation of the personnel policies and therefore this leads to the rejection of the hypothesis.

As to incentives and rewards system, the obtained t-value was 61.96 which is greater than the t-critical value of 2.35 at .05 level of significance. Hence, there is a significant difference on the extent of implementation of the personnel policies and therefore this leads to the rejection of the hypothesis.

As to discipline, the obtained t-value was 162.79 which is greater than the t-critical value of 2.35 at .05 level of significance. Hence, there is a significant difference on the extent of the implementation of the personnel policies and therefore this leads to the rejection of the hypothesis.

Hence, based on the outcome of the results that all of the variables have a significant difference on the extent of the implementation of the personnel policies in Manila Traffic and Parking Bureau. In addition, strengthening the personnel establishment of the local administrative system by selecting qualified employees, maximizing their services providing them opportunities for career advancement is one of the primordial responsibilities. They should develop the managerial competences in implementing policies, supervising practices and handling problems pertaining personnel management in the context of the local public service.

Sub-problem No. 3. What are the problems encountered by the respondents?

Table 9 depicts the assessment of the respondents on the problems encountered in the implementation of the personnel policies in Manila Traffic and Parking Bureau (MTPB).

Table 9
Problems Encountered

Criteria	WM	VI	Rank
1. Aspirants are selected through recommendations from their officials.	3.56	E	9
2. Insufficient technical know-how of immediate superior/employee charge recruitment and selection.	3.71	E	3
3. Applicants who do not meet the minimum educational credentials, yet, have the necessary experience and skill cannot be appointed to higher position.	3.58	E	8
4. MTPB are covered by the position and compensation of the National Government but the compensation and benefits received by the local government vary, this is due to the disparities in the financial capability of the MTPB.	3.52	E	11
5. There is no infirmity and equality in compensation and benefits.	3.88	E	1
6. Invitations and training programs normally specify the target participants who are usually the elective officials or department heads, this makes the rank and file totally alien from the capability-building programs intended for the MTPB.	3.63	E	5
7. There is a lack of opportunities for career advancement and the system does not provide a career pattern to follow.	3.59	E	6.5
8. Training and development are left to a selected political protégé (influential person).	3.76	E	2
9. Results of performance evaluation are not always operationally applied and it is almost seen at routine activity.	3.59	E	6.5
10. Lack of incentives, rewards and recognition for outstanding performance on the job.	3.50	E	12
11. Grounds for disciplinary action are not followed as prescribed under existing rules and law.	3.54	E	10
12. The practice political partnerships take place in the MTPB.	3.64	E	4
Overall Weighted Mean	3.63	E	

Legend:

4.50 – 5.00	Highly Encountered	(HE)
3.50 – 4.49	Encountered	(E)
2.50 – 3.49	Moderately Encountered	(ME)
1.50 – 2.49	Barely Encountered	(BE)
1.00 – 1.49	Not Encountered	(NE)

As depicted in the table, the respondents perceived all the criteria as “encountered”. Item 5 – there is no infirmity and equality in compensation and benefits (WM=3.88) ranked 1; item 8 – training and development are left to a selected political protégé (influential person) (WM=3.76) ranked 2; item 2 – insufficient technical know-how of immediate superior/employee

charge recruitment and selection (WM=3.71) ranked 3; item 12 – the practice political partnerships take place in the MTPB (WM=3.64) ranked 4; item 6 - invitations and training programs normally specify the target participants who are usually the elective officials or department heads, this makes the rank and file totally alien from the capability-building programs intended for the MTPB (both WM=3.63) ranked 5; items 7 and 9 – there is a lack of opportunities for career advancement and the system does not provide a career pattern to follow, and results of performance evaluation are not always operationally applied and it is almost seen at routine activity (WM=3.59) ranked 6.5; item 3 – applicants who do not meet the minimum educational credentials, yet, have the necessary experience and skill cannot be appointed to higher position (both WM=3.58) ranked 8; item 1 – aspirants are selected through recommendations from their officials (WM=3.56) ranked 9; items 11 – grounds for disciplinary action are not followed as prescribed under existing rules and law (WM=3.54) ranked 10; item 4 – MTPB are covered by the position and compensation of the National Government but the compensation and benefits received by the local government vary, this is due to the disparities in the financial capability of the MTPB (WM=3.52) ranked 11 and; item 10 – lack of incentives, rewards and recognition for outstanding performance on the job (WM=3.50) ranked 12, respectively.

It can be gleaned from the data that the problems encountered by the respondents was rated with an overall composite weighted mean of 3.62 interpreted as “encountered.”

CONCLUSIONS AND RECOMMENDATIONS

Based on the findings of the study, the following concluding and recommending statements are drawn:

The effectiveness of the implementation of the personnel policies in the Manila Traffic and Parking Bureau as to recruitment and selection, compensation and benefits, training and development, performance appraisal, incentives and reward system, and discipline was perceived by the respondents with an overall weighted mean of 3.57, 3.61, 3.66, 3.66, 3.68, and 3.72, respectively, interpreted as extensive.

Apparently, based on the outcome of the results, all of the variables have a significant difference on the extent of the implementation of the personnel policies in Manila Traffic and Parking Bureau with the obtained t-value of 72.15, 51.57, 63.22, 252.13, 61.96, and 162.79, respectively, which is greater than the t-critical value at 0.5 level of significance.

On the other hand, the problems encountered by the respondents was rated with an overall composite weighted mean of 3.62 interpreted as encountered.

Moreover, there are still a need for the improvement of personnel policies in the Manila Traffic and Parking Bureau for the employees to devote productively and effectively towards the attainment of the department goals and objectives.

In addition, strengthening the personnel establishment of the local administrative system by selecting qualified employees, maximizing their services providing them opportunities for career advancement is one of the primordial responsibilities.

Furthermore, develop the managerial competences in implementing policies, supervising practices and handling problems pertaining personnel management in the context of the local public service.

Lastly, flexible personnel policy is required with result-oriented policies and programs. They may establish a set of general internal operating policies in order to accommodate the specific needs of the department. Any supplemental internal policies adopted and implemented shall comply in accordance to civil service rules, regulations and laws.

REFERENCES

- Farazmand, Ali (2006). *Strategic Public Personnel Administration: Building and Managing Human Capital for the 21st Century*. London, Connecticut: Praeger Publishers.
- Llorenzs, Jared, et.al. (2017). *Public Personnel Management: Contexts and Strategies Seventh Edition*. New York: Routledge.
- Peralta-Buendia, Daisy (2008). *Personnel Administration in the Philippine Government*. Manila, Philippines: National Book Store.

SAFETY MEASURES IMPLEMENTED BY SELECTED QUICK SERVICE RESTAURANTS IN MUNTINLUPA CITY

Maria Rhoda D. Dinaga

INTRODUCTION

Most Quick Service Restaurant (QSR) players have established new health and safety processes and policies to protect employees and customers even before the advent of COVID 19. The new challenge that has been laid down to the doorstep of every QSR that has implemented include adjusting travel policies to permit only the most critical business travel, encouraging or requiring remote working for corporate staff, and amending sick-leave policies for employees affected by COVID-19. QSRs have also adjusted their on-site offerings to follow local and national guidelines—for example, by shutting down self-serve prepared-food counters, suspending all customer events, and switching to a delivery-only model. Concerning hygiene and safety, QSRs have instituted strict protocols, such as providing hand sanitizer and thermometers and training employees to minimize human contact, educating staff on the virus and how to protect themselves and others, reinforcing protocols such as physical distancing, hand washing, and improved security with people staying in their vehicles/sanitizing hands when handing out documents and other material.

The main priority of every foodservice establishment is to keep the virus out of the food environment. Therefore, measures that have been required before are upgraded not only by merely cleaning and sanitizing food contact surfaces, but disinfecting surfaces and high-touch points every thirty minutes. In addition, most QSRs have increased also the frequency and rigor of in-store cleanings especially in the kitchen area making sure to sanitize high-touch areas and these include working tables, storage door handles on coolers, and even freezers. Food Service business has also prioritized the safety of both staff and customers. Every business owner has a responsibility to assess the risks in their business and implement measures to reduce them as far as reasonably practicable. Those who have opened for public services need to continuously assess the measures they've taken and uphold them, whenever necessary. Running a safe food service business is a complex undertaking at the best of times, but is even more complex in the midst of a pandemic. Indeed, an increase in health issues due to the consumption of fast food restrains the growth to some extent.

The QSR business, by definition, is about serving customers at speed. Food safety refers to routines in the preparation, handling, and storage of food meant to prevent foodborne illness and injury. Safe food handling practices and procedures are thus implemented at every stage of the food production life cycle in order to control these risks and prevent harm to customers. If QSRs act quickly in this crisis to meet the changing needs of consumers while prioritizing people's health and well-being, QSRs can not only withstand these difficult times but also build valuable capabilities for resilience and success in the future. In this line of thought, this study is conducted in order to assess the safety measures implemented by selected Quick Service Restaurants, such as Yellow Cab and S & R in Muntinlupa City. The researcher also wants to help reduce foodborne illnesses that may arise by improving food safety-related behaviors and practices in every Quick Service Restaurant in Muntinlupa City.

METHODOLOGY

This study utilized the descriptive research design. It is designed to collect information that will help to determine the safety measure implemented by quick-service restaurants in Muntinlupa City.

Descriptive research is about describing how reality is. In this regard, descriptive research differs from prescriptive research that is primarily concerned with the question of how the reality should be. The characteristics of descriptive research in principle, it is not aiming at forming hypotheses or development theory, this research is more concerned with what rather than how why something has happened. In such research, the data may be collected qualitatively, but it is often analyzed quantitatively, using frequency, percentages, averages, or other statistical analysis to determine relationships. (Nassaji, 2015)

The research's used purposive sampling, the purposive sampling technique also called, judgment sampling, which is the deliberate choice of an informant due to the qualities the informant possesses. It is a non-probability sample that is selected based on the characteristics of a population and the objective of the study. Purposive sampling is different from convenience sampling and is also known as judgmental, selective, or subjective sampling. This type of sampling can be very useful in situations when you need to reach a targeted sample quickly, and where sampling for proportionality is not the main concern (Crossman, 2020). Thus, the number of respondents was chosen purposely on this study which are 30 for each of the establishments; Yellow Cab and S & R Pizza respectively.

RESULTS AND DISCUSSION

Sub-problem No. 1: How do the respondents assess the safety measures implemented by selected quick-service restaurants in Muntinlupa City?

Table 1
Safety Measures Implemented by Selected Quick Service Restaurants
As to Managing Employees Health

Indicator	Yellow Cab Pizza		S&R New York Style Pizza		Composite		Rank
	WM	VI	WM	VI	WM	VI	
1. Takes temperature and assesses symptoms prior to starting work).	4.47	HI	4.50	HI	4.48	HI	3
2. Disinfects and cleans workspaces and equipment.	4.57	HI	4.44	HI	4.50	HI	2
3. Regularly self-monitors their temperature as well as customers for dining.	4.20	HI	4.33	HI	4.27	HI	5
4. Wears a mask or face covering.	4.77	HI	4.60	HI	4.68	HI	1
5. Practices social distancing at least 6 feet from other people.	4.40	HI	4.40	HI	4.40	HI	4
Overall Weighted Mean	4.48	HI	4.45	HI	4.47	HI	

As presented in Table 1, the assessment on the safety measures implemented by selected quick-service restaurants as to managing employees' health rated as Highly Implemented with an overall weighted mean of 4.47. All items rated as Highly Implemented, namely: wears a mask or face with a weighted mean of 4.68 as rank 1; disinfects and clean workspaces and equipment with a weighted mean of 4.50 as rank 2; takes temperature and assess symptoms prior to starting work) with a weighted mean of 4.48 as rank 3; practices social distancing at least 6 feet from other people with a weighted mean of 4.40 as rank 4; and regularly self-monitors their temperature as well as customers for dining with a weighted mean of 4.27 as rank 5.

Further, the groups of respondents' assessments on the safety measures implemented by selected quick-service restaurants as to managing employee's health rated as Highly Implemented, such as Yellow Cab Pizza with an overall weighted mean of 4.28; S&R New York Style Pizza with an overall weighted mean of 4.45.

Table 2
Safety Measures Implemented by Selected Quick Service Restaurants
As to Practice Personal Hygiene for Employees

Indicator	Yellow Cab Pizza		S&R New York Style Pizza		Composite		Rank
	WM	VI	WM	VI	WM	VI	
1. Emphasize effective hand hygiene at all times.	4.57	HI	4.40	HI	4.48	HI	2
2. Uses soap and water and alcohol-based hand sanitizer before and after food preparation.	4.60	HI	4.40	HI	4.50	HI	1
3. Avoid touching eyes, nose, and mouth.	4.40	HI	4.33	HI	4.37	HI	5
4. Use gloves to avoid direct bare hand contact with ready-to-eat foods.	4.50	HI	4.35	HI	4.43	HI	3
5. Covers mouth when coughing or sneezing with a tissue.	4.53	HI	4.27	HI	4.40	HI	4
Overall Weighted Mean	4.52	HI	4.35	HI	4.44	HI	

As shown in Table 2, the assessment on the safety measures implemented by selected quick-service restaurants as to practice personal hygiene for employees rated as Highly Implemented with an overall weighted mean of 4.44. All items rated as Highly Implemented, these are: uses soap and water and alcohol-based hand sanitizer before and after food preparation with a weighted mean of 4.50 as rank 1; emphasize effective hand hygiene at all times with weighted mean of 4.48 as rank 2; use gloves to avoid direct bare hand contact with ready-to-eat foods with a weighted mean of 4.43 as rank 3; covers cough or sneeze with tissue with a weighted mean of 4.40 as rank 4; and avoid touching eyes, nose, and mouth with a weighted mean of 4.37 as rank 5.

Further, the groups of respondents' assessments on the safety measures implemented by selected quick-service restaurants as to practice personal hygiene for employees rated as Highly Implemented, such as Yellow Cab Pizza with an overall weighted mean of 4.52; S&R New York Style Pizza with an overall weighted mean of 4.35.

As displayed in Table 3, the assessment on the safety measures implemented by selected quick-service restaurants as to managing operations in a dining area rated as Highly Implemented with an overall weighted mean of 4.46. All items rated as Highly Implemented, namely: prepare and use sanitizers according to label instructions with weighted mean Of 4.52 as rank 1; strict imposition of No facemask and No face shield is no entry with a weighted mean of 4.50 as rank 2; applies procedure that ensures food safety with a weighted mean of 4.48 as rank 3; wash, rinse, and sanitize food contact surfaces dishware, utensils, food preparation surfaces, and beverage equipment after use with a weighted mean of 4.47 as rank 4; always follow the key steps: clean, separate, and chill with a weighted mean of 4.46 as rank 5; monitor customers distance especially for dining couples with a weighted mean of 4.43 as rank 6; help customers maintain good infection control and social distancing with a weighted mean of 4.40 as rank 7; and frequently disinfect surfaces repeatedly touched by employees or customers

such as doorknobs, equipment handles, check-out counters, and grocery cart handles, etc. with a weighted mean of 4.38 as rank 8.

Table 3
Safety Measures Implemented by Selected Quick Service Restaurants
As to Managing Operations in a Dining Area

Indicator	Yellow Cab Pizza		S&R New York Style Pizza		Composite		Rank
	WM	VI	WM	VI	WM	VI	
1. Always follow the key steps: clean, separate, and chill.	4.47	HI	4.45	HI	4.46	HI	5
2. Wash, rinse, and sanitize food contact surfaces dishware, utensils, food preparation surfaces, and beverage equipment after use.	4.57	HI	4.37	HI	4.47	HI	4
3. Frequently disinfect surfaces repeatedly touched by employees or customers such as doorknobs, equipment handles, check-out counters, and grocery cart handles, etc.	4.40	HI	4.37	HI	4.38	HI	8
4. Prepare and use sanitizers according to label instructions.	4.50	HI	4.54	HI	4.52	HI	1
5. Applies procedure that ensures food safety.	4.53	HI	4.43	HI	4.48	HI	3
6. Help customers maintain good infection control and social distancing.	4.43	HI	4.37	HI	4.40	HI	7
7. Monitor customers distance especially for dining couples	4.53	HI	4.33	HI	4.43	HI	6
8. Strict imposition of No facemask and No face shield is no entry.	4.50	HI	4.50	HI	4.50	HI	2
Overall Weighted Mean	4.49	HI	4.42	HI	4.46	H	

Further, the groups of respondents' assessments on the safety measures implemented by selected quick-service restaurants as to managing operations in a dining area rated as Highly Implemented, such as Yellow Cab Pizza with an overall weighted mean of 4.49; S&R New York Style Pizza with an overall weighted mean of 4.42.

As manifested in Table 4, the assessment on the safety measures implemented by selected quick-service restaurants as to managing food pick-up and delivery rated as Highly Implemented with an overall weighted mean of 4.39. All items rated as Highly Implemented, these are: practice social distancing when delivering food, e.g., offering "no touch" deliveries with weighted mean of 4,53 as rank 1; observe established food safety practices with weighted mean of 4.45 as rank 2; establish designated pick-up zones for customers to help maintain social distancing with weighted mean of 4.43 as rank 3; clean and sanitize coolers and insulated bags used to deliver foods with weighted mean of 4.40 as rank 4; ensure that any food is wrapping and package properly for transport with weighted mean of 4.38 as rank 5; increase the frequency of cleaning and disinfecting of high-touch surfaces with cleaning spray or wipe with weighted mean of 4.37 as rank 6; maintain social distancing if offering take-out/carry-out option with weighted mean of 4.35 as rank 7; keep hot foods hot and cold foods cold by storing in appropriate transport vessels with weighted mean of 4.38 as rank 8; keep foods separated to avoid cross contamination with weighted mean of 4.32 as rank 9; and

encourage employees to wash hands often with soap and water for at least 20 seconds with weighted mean of 4.30 as rank 10.

Table 4
Safety Measures Implemented by Selected Quick Service Restaurants
As to Managing Food Pick-up and Delivery

Indicator	Yellow Cab Pizza		S&R New York Style Pizza		Composite		Rank
	WM	VI	WM	VI	WM	VI	
1. Observe established food safety practices.	4.50	HI	4.40	HI	4.45	HI	2
2. Encourage employees to wash their hands often with soap and water for at least 20 seconds.	4.30	HI	4.30	HI	4.30	HI	10
3. Increase the frequency of cleaning and disinfecting of high-touch surfaces with cleaning spray or wipe.	4.37	HI	4.37	HI	4.37	HI	6
4. Establish designated pick-up zones for customers to help maintain social distancing.	4.40	HI	4.45	HI	4.43	HI	3
5. Practice social distancing when delivering food, e.g., offering "no-touch" deliveries.	4.40	HI	4.65	HI	4.53	HI	1
6. Maintain social distancing if offering take-out/carry-out option.	4.40	HI	4.30	HI	4.35	HI	7
7. Keep hot foods hot and cold foods cold by storing inappropriate transport vessels.	4.33	HI	4.33	HI	4.33	HI	8
8. Keep foods separated to avoid cross-contamination.	4.33	HI	4.30	HI	4.32	HI	9
9. Ensure that any food is ensured wrapped and packed properly for transport.	4.37	HI	4.40	HI	4.38	HI	5
10. Clean and sanitize coolers and insulated bags used to deliver foods.	4.40	HI	4.40	HI	4.40	HI	4
Overall Weighted Mean	4.38	HI	4.39	HI	4.39	HI	

Further, the groups of respondents' assessments on the safety measures implemented by selected quick-service restaurants as to managing food pick-up and delivery rated as Highly Implemented, such as S&R New York Style Pizza with an overall weighted mean of 4.39; Yellow Cab Pizza with an overall weighted mean of 4.38.

Table 5
Summary on the Safety Measures Implemented by Selected Quick Service Restaurants

Indicator	Yellow Cab Pizza		S&R New York Style Pizza		Composite		Rank
	WM	VI	WM	VI	WM	VI	
1. Managing Employee Health	4.48	HI	4.45	HI	4.47	HI	1
2. Practice of Personal Hygiene for Employees	4.52	HI	4.35	HI	4.44	HI	3
3. Managing Operations in a Dining Area	4.49	HI	4.42	HI	4.46	HI	2
4. Managing Food Pick-Up and Delivery	4.38	HI	4.39	HI	4.39	HI	4
Overall Weighted Mean	4.47	HI	4.40	HI	4.44	HI	

As summarized in Table 5, the overall assessment on the safety measures implemented by selected quick-service restaurants with the grand mean of 4.32. All items rated as Implemented, namely: managing employee health with a weighted mean of 4.47 as rank 1; managing operations in a dining area with a weighted mean of 4.46 as rank 2; practice of personal hygiene for employees with a weighted mean of 4.44 as rank 3; and managing food pick-up and delivery with a weighted mean of 4.39 as rank 4.

Generally, the group overall assessment on the safety measures implemented by selected quick service restaurants rated as Highly Implemented, such as Yellow Cab Pizza with the grand mean of 4.47; and S&R New York Style Pizza with the grand mean of 4.40.

Sub-problem No. 2: Is there a significant difference between the assessments of the two groups of respondents as to the aforementioned variables?

Table 6
Comparative Assessment on the Safety Measures Implemented by Selected Quick Service Restaurants

Indicator	Yellow Cab Pizza		S&R New York Style Pizza		t-value	Decision	Interpretation
	WM	SD	WM	SD			
1. Managing Employee Health	4.48	0.044	4.45	0.010	0.01813	Accept Ho	Not Significant
2. Practice of Personal Hygiene for Employees	4.52	0.006	4.35	0.003	0.11053	Accept Ho	Not Significant
3. Managing Operations in a Dining Area	4.49	0.004	4.42	0.005	0.04018	Accept Ho	Not Significant
4. Managing Food Pick-Up and Delivery	4.38	0.003	4.39	0.012	0.01067	Accept Ho	Not Significant

Legend: critical value of 1.671 with 58 degree of freedom at 0.05 level of significance

As depicted in Table 6, the computed t-values: managing employee health with 0.01813; practice personal hygiene for employees with 0.11053; managing operations in a dining area with 0.04018; and managing food pick-up and delivery with 0.01067 were all lower than the critical value of 1.671 with 58 degree of freedom at 0.05 level of significance. Hence, there is no significant difference on the safety measures implemented by selected quick service restaurants when grouped according to restaurants. Therefore, the hypothesis is accepted.

Sub-problem No. 3: What are the problems encountered by the respondents?

As identified in Table 7, the assessment of the problems encountered on the safety measures implemented by selected quick service restaurants rated as Least Encountered with an overall weighted mean of 1.80. five (5) items rated as Least Encountered, these are no practice of social distancing when queuing with a weighted mean of 1.96 as rank 1; seldom disinfect surfaces repeatedly touched by employees or customers with a weighted mean of 1.90 as rank 2; do not encourage customers to maintain good infection control and social distancing with a weighted mean of 1.88 as rank 3; employees do not use gloves when

touching food with a weighted mean of 1.83 as rank 4; and no frequent cleaning of high touch surfaces with a weighted mean of 1.82 as rank 5. Five (5) items were rated as Not Encountered, namely: lack of soap and water and or alcohol-based hand sanitizer with a weighted mean of 1.79 as rank 6; no roving employees to monitor customers distance especially for dining couples with a weighted mean of 1.77 as rank 7; no designated pick-up zones for customers to help maintain social distancing with a weighted mean of 1.72 as rank 8; leniency of practice for social distancing when serving food with a weighted mean of 1.70 as rank 9; and no Strict imposition of “No facemask and No face shield is no entry with a weighted mean of 1.68 as rank 10.

Table 7
Problems Encountered on the Safety Measures Implemented
by Selected Quick Service Restaurants

Indicator	Yellow Cab Pizza		S&R New York Style Pizza		Composite		Rank
	WM	VI	WM	VI	WM	VI	
1. Not consistently cleaning of high-touch surfaces.	1.80	LE	1.83	LE	1.82	LE	5
2. Less practice of social distancing when queuing.	1.93	LE	1.98	LE	1.96	LE	1
3. Lack of soap and water and or alcohol-based hand sanitizer.	1.80	LE	1.78	NE	1.79	NE	6
4. Employees do not use gloves when touching food.	1.80	LE	1.87	LE	1.83	LE	4
5. Seldom disinfect surfaces repeatedly touched by employees or customers.	1.83	LE	1.97	LE	1.90	LE	2
6. Seldom encourage customers to maintain good infection control and social distancing.	1.97	VLE	1.80	VLE	1.88	VLE	3
7. Limited designated pick-up zones for customers to help maintain social distancing.	1.80	VLE	1.63	NE	1.72	NE	8
8. Leniency of practice for social distancing when serving food.	1.63	NE	1.77	NE	1.70	NE	9
9. Few roving employees to monitor customers distance especially for dining couples	1.77	NE	1.77	NE	1.77	NE	7
10. Leniency on the imposition of “No facemask and No face shield is no entry.	1.67	NE	1.70	NE	1.68	NE	10
Overall Weighted Mean	1.80	VLE	1.81	VLE	1.80	VLE	

Further, the groups of respondent's assessments of the problems encountered on the safety measures implemented by selected quick service restaurants rated as Least Encountered, such as S&R New York Style Pizza with an overall weighted mean of 1.81; Yellow Cab Pizza with an overall weighted mean of 1.80.

CONCLUSIONS AND RECOMMENDATIONS

Based from the findings of the study, the following are the conclusions:

1. The customers have highly enforced the implementations with the safety measures implemented by selected quick-service restaurants.
2. The respondents share a parallel assessment as to the safety measures implemented by selected quick-service restaurants.
3. The two groups of respondents slightly meet constraints on the safety measures implemented.

From the conclusions, the following are the recommendations:

1. The Management of the two selected quick-service restaurants may keep up the status of the implemented safety measures in order to have repeat business that would redound to more sales.
2. The two quick-service restaurants may innovate/introduce more preventative measures to secure the safety of their customers and employees.
3. The Management may collaborate convenient preventative measures that protect employees and make other customers feel safe that will remain their restaurant as number one priority. Other least encountered problems may be addressed to ensure 100% quality of the safety measures implemented.
4. A parallel study may be conducted using the same variables and setting but different respondents in order to validate the reliability of the findings.

REFERENCES

- Banzuelo, L. R. (2020), Asian cuisine, Mindshapers Co, Inc. ICP Building, Recoletos cro Cabildo St., Intramuros, Manila
- Dinaga, M. R. D. 2015, Culinary arts a practical handbook, C&E Publishing House Inc., West Triangle, Quezon City.
- Dinaga, M. R. D. & Lirazan, T.P., (2019) Commercial baking with entrepreneurship, Mindshapers Co, Inc. ICP Building, Recoletos cro Cabildo St., Intramuros, Manila
- Gisslen, W. (2012), The professional cooking, 7th ed. John Wiley and Sons, Inc., Hoboken, New Jersey
- Suas, M. (2012, Advanced bread and pastry a professional approach, Delmar, Cengage Learning, 5 Maxwell Drive Clifton Park, NY 12065-2919 USA
- Adane, Teka, Gismu, Haleform, Ademe (2018) Food hygiene and safety measures among food handlers in street food shops and food establishments of Dessie town, Ethiopia: A community-based cross-sectional study. Retrieved from <https://journals.plos.org/plosone/article?id=10.1371/journal.pone.0196919>
- Andarada, Bigtas, Ribo Jr (2019), Development of Food Safety Plan for Food Parks in the Philippines. Retrieved from <http://www.ieomsociety.org/ieom2019/papers/547.pdf>
- Arezza, M.K. (2018), On Food Safety and Sanitation: Analyzing the Knowledge, Attitudes, and Practices (KAP) of Head Cooks in Casual Dining Restaurants in Manila and Makati. Retrieved from <https://irbas.academyiribr.com/papers/1549257788.pdf>
- Bradley, M. The Difference between QSR, Fast Casual & Casual Dining Restaurants, June 19, 2018, <https://www.partech.com/blog/the-difference-between-qsr-fast-casual-casual-dining/>
- Brizek, Frash, McLeod, Patience (2021), Independent restaurant operator perspectives in the wake of the COVID-19 pandemic. Retrieved from <https://www.sciencedirect.com/science/article/pii/S0278431920303182?fbclid=IwAR3neoZsCYe-wSxflLHPNslrGeS-3LWYBAQXahrQwmfmdvo0kqK9-87r7bk#sec0080>
- Department of Labor and Employment Occupational Safety and Health Center (2020), Basic Occupational Safety and Health Training. Retrieved from http://www.oshc.dole.gov.ph/images/OSHTrainingAnnouncement/BOSH-Manual_Narrative-Handout.pdf
- Department of Public Health City of Philadelphia, (2020) Guidance for restaurants p. 1. Retrieved from <https://www.phila.gov/media/20200529130422/Guidelines-for-Restaurants-Mobile-Food-Vendors.pdf>
- Djekic et al., (2021) Covid-19 pandemic effects on food safety - multi-country survey study retrieved from <https://www.sciencedirect.com/science/article/pii/S0956713520307167?fbclid=IwAR1WGuaEBx9exQmiAXMoFYBboTezPkJEj4tJRfN0i1hiVjjHJYBdfnK9Kul#sc4>
- Nuestro, E. (2020) New normal, new protocols: a deep dive into metro manila's evolving dining scene. <https://ph.asiatatler.com/dining/new-normal-new-protocols-dining-scene-June-2020>

- Fontanilla, Natividad, Tecson, Magdamit Jr (2016), FOOD AND SAFETY SANITATION OF BON APPEATEA IN LAGUNA CENTRAL, STA. ROSA CITY. Retrieved from <https://ejournals.ph/article.php?id=11146>
- Gomes de Freitas, Stedefeldt (2020) COVID-19 pandemic underlines the need to build resilience in commercial restaurants' food safety. Retrieved from <https://www.sciencedirect.com/science/article/pii/S096399692030497X#s0025>
- Hu, Wu (2020) Creating a safe haven during the crisis: How organizations can achieve deep compliance with COVID-19 safety measures in the hospitality industry. Retrieved from <https://www.sciencedirect.com/science/article/pii/S0278431920302140#sec0120>
- Kim, JK, Kim, J & Wang (2020) Uncertainty risks and the strategic reaction of restaurant firms amid COVID-19: Evidence from China. Retrieved from <https://www.sciencedirect.com/science/article/pii/S0278431920303042#sec0070>
- Legaspi, J. (2020) Food, Lifestyle: McDonald's levels up with M Safe Campaign. Retrieved from <https://mb.com.ph/2020/07/11/mcdonalds-levels-up-with-m-safe-campaign/>
- MBA Skool Team, (2019) Quick Service Restaurant (QSR) Published by MBA Skool Team, April 18, 2019, <https://www.mbaskool.com/business-concepts/marketing-and-strategy-terms/17868-quick-service-restaurant-qsr.html>
- Dajao, N. P. (2017), Food handlers' attributes, food safety compliance and risk for food poisoning. Retrieved from <https://www.herdin.ph/index.php/component/herdin/?view=research&cid=63822>
- Razali (2018), A Study on Safety Management Practices and Safety Performance. Retrieved from https://www.researchgate.net/publication/326722322_A_Study_On_Safety_Management_Practices_And_Safety_Performance
- Rizou, I. M. Galanakis, Aldawoud, C. M. Galanakis (2020) Safety of foods, food supply chain and environment within the COVID-19 pandemic. Retrieved from <https://www.sciencedirect.com/science/article/pii/S0924224420305094#sec5>
- Secreto, Rivera (2017), A study on the effectiveness of the manila health department in implementing pd 856 sec. 14 to food establishments in Intramuros, manila. Retrieved from <https://ejournals.ph/article.php?id=11604>
- Shaw, F. Journal of Food: Microbiology, Safety & Hygiene, The importance of food safety and hygiene, August 30-31, 2018 Dubai, UAE <https://www.longdom.org/proceedings/the-importance-of-food-safety-and-hygiene-45262.html>
- Weiler, Fernandez (2020) Food safety is everybody's responsibility. Retrieved from <https://www.who.int/philippines/news/commentaries/detail/food-safety-is-everybody-s-responsibility>

STATUS OF INTER-FAITH SERVICE AND ITS PROMOTIONAL STRATEGIES IN EARIST SCALE CONSTRUCTION FIRMS IN FIRST CLASS CITIES IN METRO MANILA: BASIS FOR FULL IMPLEMENTATION

Ronaldo F. Doroteo

INTRODUCTION

In faith miracles happen! This statement signifies that life goes beyond material life and science. There are things that we could not explain why it occurs in our daily lives. A reason why there are conceptions of faith organization believing that what saves us from any harm beyond our control is our faith in the creator who made us and the source of what we have.

Faith Organization is a support to the government in fulfilling some of its functions. These functions are vital in promoting the moral and spiritual well-being of men.

The researchers now being much interested in this issue intend to investigate the Status of Inter-faith service and its promotional strategies in EARIST.

This study is designed to promote the interfaith services of EARIST. Specifically, it seeks to answer the following question.

1. What is the status of Inter-faith Services as to:
 - 1.1 Recruitment & Selection
 - 1.2 Pre-Accreditation
 - 1.3 Orientation Program
 - 1.4 Ecumenical Services
 - 1.5 Students Community Services
2. What is the Extent of Promotional Strategies of Interfaith Services in terms of:
 - 2.1 Print media
 - 2.2 Social media
 - 2.3 Word of mouth
 - 2.4 Events
3. Is there a significant difference in the promotional strategies of Inter-faith services as assessed by the students, faculties, and members?
4. Based on the findings, what promotional plan may be proposed for enhancement?

METHODS

The study used the descriptive method of research, which would describe and analyze the Promotion of Inter-faith services and its impact to the community to the Faith leaders, Faith

Servant Volunteers and Community Members of Eulogio “Amang” Rodriguez Institute of Science and Technology.

John Dudovskiy (2019) an important characteristic of descriptive research relates to the fact that while descriptive research can employ a number of variables, only one variable is required to conduct a descriptive study. Three main purposes of descriptive studies can be explained as describing, explaining and validating research findings.

The data collected in the study were organized and classified based on the research design and problems formulated. The data were coded, tallied, tabulated, and tabled to facilitate the presentation and interpretation of results using the following:

1. Frequency. It is the actual response to a specific item/question in the questionnaire where the respondent ticks his choice.

2. Percentage. To determine the relations of a part to a whole. Are used to express numbers between zero and one.

$$\text{Formula: Percentage} = \frac{F}{N} * 100$$

Where :

f = Number of Responses
n = Total Number of Observation
P = Percentage

3. Weighted Mean. It is the sum of the item values divided by the total number of items. It is computed average and its magnitude is influenced by every one of the item values in the set, and used to describe as set of quantitative data provided the item values that constitute the set are considerably concentrated. It is computed by adding and dividing the sum by the total number of scores.

$$\text{Formula: WM} = \frac{\sum WX}{\sum M}$$

Where :

WM = Weighted Mean
X = Any Particular Value
M = Associated Mean

4. Likert Scale. The data interpreted by using the Four (5) Likert Scale Method, as the criterion which serves as the basis for the interpretation of the data. The concept of the boundary of the numerals will be used as follows:

Scale	Range	Verbal Interpretation	Symbol
5	4.50 – 5.00	Highly Implemented	HI
4	3.50 – 4.49	Implemented	I
3	2.50 – 3.49	Moderate Implemented	MI
2	1.50 – 2.49	Least Implemented	LI
1	1.00 – 1.49	Not Implemented	NI

Ranking. This was used to determine the order of decreasing or increasing magnitude of variations. The largest frequency is ranked number 5, 4 and so on down to the last rank and number.

4. Analysis of Variance (ANOVA). This was used to determine if there is significant difference among the three groups of respondents.

$$\text{Formula: TSS} = \frac{\sum X^2 - (\sum X)^2}{N}$$

Where:

TSS = total sum of squares
 X = individual values in each column
 N = total sample size

$$\text{SSB} = \frac{(\sum X)^2}{n} - \frac{(\sum X)^2}{N}$$

Where:

SSB = sum of squares between columns
 $\sum X^2$ = sum of the individual values per column
 N = size of the sample per column

Where:

SSW = sum of squares within columns

RESULT

Table 1
Summary on the Assessment of Promotional Strategies of Interfaith Service

Indicator	Overall	Rank	Indicator
	WM	VI	
1. Print Media	4.14	I	4
2. Social Media	4.19	I	3
3. Word of Mouth	4.39	HI	2
4. Events	4.40	HI	1
Grand Mean	4.28	HI	

Table 1 shows the summary on the assessment of promotional strategies of Inter-Faith services rated Highly Implemented with the grand mean of 4.28. Two items rate Highly Implemented namely: Events with overall weighted mean of 4.40 as rank 1; and word of mouth with overall weighted mean of 4.39 as rank 2. Two items rated Implemented such as: social media with overall weighted mean of 4.19 as rank 3; and print media with overall weighted mean of 4.14 as rank 4.

Sub-problem No. 3: Is there significant difference in the promotional strategies of Inter-faith services as assessed by the faith leaders, faith servant volunteers, and community members?

Table 2
Comparison of the Assessments of the Respondents on the Promotional Strategies of Inter-faith Services

Indicator	SS	df	MS	Critical F-value	Computed F-value	Int.	Decision
Print Media Between Groups Within Groups	0.15 9.02	2 6	0.07 1.50	5.14	0.05296	Not Significant	Accept Ho
Social Media Between Groups Within Groups	0.02 9.00	2 6	0.01 1.50	5.14	0.00783	Not Significant	Accept Ho
Word of Mouth Between Groups Within Groups	0.03 9.00	2 6	0.01 1.50	5.14	0.01292	Not Significant	Accept Ho
Events Between Groups Within Groups	0.14 9.00	2 6	0.07 1.50	5.14	0.04747	Not Significant	Accept Ho

As manifested in Table 2, the computed F-values are as follows: print media (0.05296); social media (0.00783); word of mouth (0.01292); and events (0.04747) were all lower than the critical values of 5.14 with the degree of freedom of 2 and 6 at 0.5 level of significance. Hence, there is no significant difference on the promotional strategies of Inter-faith services as assessed by the faith leaders, faith servant volunteers, and community members. Therefore, the hypothesis is accepted.

Sub-problem No. 4: What are the problems encountered by the respondents in the promotional strategies of Inter-faith Service?

Table 3 reveals the assessment in the problems encountered in the Inter-Faith Services rated Encountered with the overall weighted mean of 3.65. One item rated Highly Encountered which is Promoting activities of Inter-faith office is sufficient to sustain its operation about the organization activities with weighted mean of 4.23 as rank 1. Three items rate Encountered these are: The Inter-faith office has enough budgets for the promotional tools being use and support of school administration with weighted mean of 3.68 as rank 2; All the students have given enough time to participate despite of their class schedule with weighted mean of 3.65 as rank 3; and Inter-faith office respond to what the trend is to get attention from the students which sometimes is not applicable to the student needs with weighted mean of 3.48 as rank 4. One item rated Moderately Encountered which is Students sometimes think what the office gives them in return if they participate in faith organization with weighted mean of 3.24 as rank 5.

Table 3
Problems Encountered By the Respondents in the
Promotional Strategies of Inter-faith Service

Promotional Strategies	Faith Leaders		Faith Servant Volunteers		Community Member		Composite		Rank
	WM	VI	WM	VI	WM	VI	WM	VI	
1. Promoting of activities if Inter-faith office is sufficient to sustain its operation about the organization activities.	4.25	HE	4.50	HE	3.94	E	4.23	HE	1
2. All the students have given enough time to participate despite of their class schedule.	3.33	ME	4.00	E	3.61	E	3.65	E	3
3. The inter-faith office has enough budgets for the promotional tools being use and support administration.	3.58	E	4.00	E	3.45	E	3.68	E	2
4. Inter-faith office respond to what the trend is to get attention from the students which sometimes is not applicable to the student needs.	3.25	ME	4.00	E	3.19	ME	3.48	E	4
5. Students sometimes think what the office gives them in return if they participate to join in faith organization.	3.33	ME	3.00	ME	3.39	ME	3.24	ME	5
Ovaerll Weighted Mean	3.55	E	3.90	E	3.52	E	3.65	E	

As to the group of respondents' assessment: Faith Volunteers with overall weighted mean of 3.90; Faith Leaders with overall weighted mean of 3.55; and Community members with overall weighted mean of 3.52.

Relatively, Hakes (2011) said that most discussion about social media and the church focus on the ability of tools such as Facebook and Twitter to help a church either better reach people especially during this time of pandemic that the only way that we can gather is through online.

Lomague (2011) said that the church is working with extra effort for the growth of the church and activities. As to the promotions of the churches, there are many ways that churches in the Philippines are using them.

DISCUSSION

The salient findings of the study are as follows:

The summary of the assessment in the status of the Inter-Faith services rated as Highly Observed with grand mean of 4.31. All items rated Highly Observe these are: Pre-

accreditation; Orientation Program; Ecumenical Services as; Community Services; and Recruitment and Selection.

The assessment of promotional strategies of Inter-Faith services rated Highly Implemented with the grand mean of 4.28. Two items rate Highly Implemented namely: Events; and word of mouth. Two items rated Implemented such as: social media; and print media.

The computed F-values are as follows: print media; social media; word of mouth; and events were all lower than the critical values of 5.14 with the degree of freedom of 2 and 6 at 0.5 level of significance. Hence, there is no significant difference on the promotional strategies of Inter-faith services as assessed by the faith leaders, faith servant volunteers, and community members. Therefore, the hypothesis is accepted.

Based on the findings of the study, the following conclusions are drawn:

Status of the Inter-Faith services rated as Highly Observed.

The assessment of promotional strategies of Inter-Faith services rated Highly Implemented.

Promotional Strategies of Inter-faith services in terms of print media, social media, word of mouth, and events have no effect in promoting services of Inter-faith offices.

REFERENCES

- UShawchuck, N., Ph. Kotler, B. Wrenn and G. Rath. (2009). *Marketing for Congregations: Choosing to Serve People More Effectively*. Nashville: Abingdon Press.
- Kroeger, J. (2009). *Evangelization in the Philippine Church*. Philippine Studies Ateneo De Manila University, Quezon City.
- Lomague, A., OP (2011). *Evangelization in the Philippines*.
- Templo, I. (2011). *The truth shall set you free: The role of the Church-owned radio stations in the Philippines*. Center for Freedom and Responsibility
- Fisichella, ABP. (2012). *ABP Fisichella: We need new evangelizers*. News.VA 2012-08-09 Vatican Radio.
- Santana, A. (2010). *New Media, New Evangelization: The Unique Benefits of New Media and Why the Catholic Church Should Engage Them*, (Master's Thesis). St. Mary's University, Texas.
- Dankasa, J. (2010). *New Media As Tools for evangelization: Towards Developing Effective Communication Strategy In the Catholic Church*. (Master's Thesis). St. Cloud University, Minnesota.
- Kucaba, P. (2014). *An Attitude to the Symptoms of Marketing in the Church in One Religious Society*, Maria Curie Skłodowska University, Poland.
- Padilla, F. (2012). *The New Evangelization in the Philippine Setting, Celebrating 500 years of Christianity in the Philippines*, (Thesis Proposal).

- Abare, B. & Hendricks K. (2009). Marketing Your Church Without Diluting Your Message, Retrieved from: <http://ministrytodaymag.com/outreach/marketing/11033-marketing-your-church-without-diluting-your-message>
- Hakes, D. (2011). Ideas & Inspiration, Reaching inward, Social Media. Retrieved from. <http://www.internettoolboxforchurches.com/church-social-media-use-for-internal-interaction>.
- Internet Evangelism Day (2015). Under Creative Commons License, Retrieved from:<http://www.internetevangelismday.com/church-social-media.php#ixzz3qcHz33LB>
- Lomague, A., OP (2011). Evangelization in the Philippines. Retrieved from. <https://serimben.wordpress.com/2011/08/07/evangelization-in-the-philippines/>.
- Pope Benedict XVI (2011), "Homily of First Vespers on the Solemnity of the Holy Apostles Peter and Paul," The Vatican, http://www.vatican.va/holy_father/benedict_xvi/homilies/2010/documents/hf_ben-xvi_hom_20100628_vespri-pietro-paolo_en.html.
- Templo, I. (2011). The truth shall set you free: The role of the Church-owned radio stations in the Philippines.

PHYSICAL PLANT AND FACILITIES AND ITS RELATIONS TO STUDENT ACADEMIC PERFORMANCE: BASIS FOR COLLEGE MODERNIZATION PROGRAM

*Estrelita S. Glodo
Fernando N. Filler
Irma F. Filler*

INTRODUCTION

The quality and adequacy of physical plant and facilities of a learning institution determine to a large measure the success of its curricular program. In a broad sense, physical plant and facilities include school site, campus, buildings and other infrastructures, equipment and complement institutional and program effectiveness.

STATEMENT OF THE PROBLEM

1. How do the students assess the physical plant and facilities as to:
 - 1.1 Site;
 - 1.2 Campus;
 - 1.3 Buildings;
 - 1.4 Classrooms;
 - 1.5 Offices, Function Rooms and Staff Rooms;
 - 1.6 Medical and Dental Clinic;
 - 1.7 Student Center; and
 - 1.8 Food Services?
2. What is the student academic performance in the last academic year?
3. Is there significant relationship between the physical plant and facilities and student academic performance?
4. Based from the findings, what college modernization program maybe proposed?

SIGNIFICANT OF THE STUDY

The finding of this study could be benefit to the following:

Institution. Thus, should focus greater attention on the impacts of physical plant and facilities and adopt a long-term cost-benefit perspective on efforts to improve school facilities.

School Administrators. This study may guide them how to maintain good school in regards of physical plant and facilities and for them to garner more students to enroll the school.

Students. To us, we will have the chance to extend this information to our colleagues, friends, relatives, family and even to our fellow citizens who has been hard to choose the perfect school to enroll where good facilities are provided with the school.

Faculty. This study will help faculty in their curricula to be consistent with the educational goal of the institution; enhancing student in learning experience.

Alumni. This study will help to the alumni stakeholders in having program for the future students to be more active; and it is also a reference on how to manage and improve the current situation of the institution.

Future Researchers. This may serve as a reference and added study to those interested to undertake similar research in other places at a different point in time.

SYNTHESIS OF RELATED LITERATURE

The foregoing literature and studies will provide the researchers the necessary insights and ideas towards the conceptualization of the present study. These will also be used as valuable background information in the interpretation and analysis of the findings of the study.

Ali et al. (2013) and Kwesiga (2011) shared the thoughts about the type of school a child attends influences the educational outcomes and academic performances of the students.

Odupurokan (2011), Hughes and Lyons, Akomolafe (2016), Oluremi (2012), Pallone (2012), Glewwe (2011), Monteiro (2014), Harris (2013), Okabe (2013), Shanani (2015) and Lackeny (2019) talk about guidelines to handling school maintenance and renovation issues. They observed that a poor facility leads to poor performance of every student.

Mark Phillip (2014), supported by Ryan Hannah (2014) conducted a study aimed to look on classrooms involvement in the academic performance of student.

Attfeld and Vu (2013) and Jasper, Le and Bartram (2012), Adukia (2013) and Garn (2014) and Hezoli (2012) their studies indicates that most investigations correlate a school's sanitary facilities with either increased attendance or better health conditions.

Gao, Podlog and Harrison, Coelho (2012) according to them school site is the next to school building which school building must be structurally – stable to resist lateral forces, such as earthquake, strong wind and others.

Patil and Metri (2016) opined that physical education in general, plays a prominent role for the reason that all colleges authorities have to provide opportunities to develop leadership qualities and facilities for participation that will pupils to achieve their objectives that are valuable in life.

Monteiro (2014) Harris et al (2013) Glewwe et al (2011) the authors states that, the facilities or the learning environment affects the respondents in having fairly satisfactory grades in the physical education especially in developing countries.

Attfeld and Vu (2013) Jasper, Le and Bartram (2012) Adukia (2013) Garn et al (2014) and Burton (2013) their findings said that more toilet facilities were also significantly associated with the top performing schools regardless of location, where (WASH) water, sanitation and hygiene is a key public health. Sanitary increased attendance or health condition.

Lyons (2011) back up by Fillardo opined that student performance and achievement depended upon the age, design, and condition of the school facilities when noted that public schools are constantly confronted with out-to-date design, deteriorating condition, the problem then clearly result to serious ramifications in student learning and achievement.

METHODOLOGY

The researcher's applied a Descriptive method to initiate an investigation on physical plant and facilities and its relation to student academic performance in EARIST manila specifically in College of Business Administration thru the use of survey questionnaire. The main source is the survey questionnaire which was develop by the researchers and will be given to the respondents in random students from CBA of the EARIST. Respondents help the researchers to justify their study according to the method chosen wherein the data collected will be recorded generated and will be set for analysis. As part of the analysis process, the collected information measured thru tabulation of the data and statistical calculation to help the researchers interpret the findings for pattern and relation between each problem that will or might arise. The findings then, give way to the researchers to generalize and propose their conclusion and recommendation regarding their study.

RESULTS AND DISCUSSION

Table 1
Summary on the Assessment of Physical Plant and Facilities

Indicator	WM	VI	Rank
1. Site	3.85	VS	4.5
2. Campus	3.92	VS	3
3. Buildings	3.70	VS	7
4. Classrooms	3.85	VS	4.5
5. Offices and Staff Room	4.00	VS	1
6. Medical and Dental Clinic	3.93	VS	2
7. Student Center	3.75	VS	6
8. Food Service/ Canteen	3.66	VS	8
Grand Mean	3.83	VS	

Table 1 shows the summary on the assessment of Physical Plant and Facilities rated Very Satisfactory with the grand mean of 3.83. All items rate Very Satisfactory namely: Offices and Staff rooms with overall weighted mean of 4.00 as rank 1; Medical and Dental Clinic with overall weighted mean of 3.93 as rank 2; Campus with overall weighted mean of 3.92 as rank 3; site and classrooms with overall weighted mean of 3.85 as rank 4.5; student center with overall weighted mean of 3.75 as rank 6; buildings with overall weighted mean of 3.70 as rank 7; and food service/ canteen with overall weighted mean of 3.66 as rank 8.

Table 2
Academic Performance in the Last Academic Year

Indicator	GWA
First Semester General Weighted Average	2.02
Second Semester General Weighted Average	1.84
Total	1.93

Table 2 depicts the academic performance in the last academic year with total average of 1.93. For two semesters ratings are: First semester with 2.02; and Second Semester with 1.84.

Table 3
Comparative Relationship between Physical Plant and Facilities and Student Academic Performance

Areas of Concern	r-value	VI	Interpretation	Decision
1. Site	0.17	NC	Not Significant	Accept Ho
2. Campus	0.36	WC	Not Significant	Accept Ho
3. Buildings	0.29	WC	Not Significant	Accept Ho
4. Classrooms	0.27	WC	Not Significant	Accept Ho
5. Offices and Staff Room	0.30	WC	Not Significant	Accept Ho
6. Medical and Dental Clinic	0.50	MC	Significant	Reject Ho
7. Student Center	0.64	SC	Significant	Reject Ho
8. Food Service/ Canteen	0.68	SC	Significant	Reject Ho

As depicted in Table3, the computed r-values for physical plant and facilities and student academic affairs are as follows: site with 0.17; classrooms with 0.27; buildings with 0.29; offices and staff room with 0.30; campus with 0.36 were negligible and weak correlation.

CONCLUSION

Based on the findings of the study, the following conclusions are drawn:

1. Physical plant and facilities found to be highly considered and observe.
2. Majority of the CBA Students have their high and good grades on last two academic years none of them were failed.
3. Physical plant and facilities in site, classrooms, buildings, offices and Medical and dental clinic, student center and food service/canteen have no effects on academic performance of CBA students.

RECOMMENDATION

From the foregoing findings and conclusion, the following recommendations are offered:

1. The school site must need to improve, have an ongoing plan and continues construction to expand facilities to use by the future students.
2. The Campus must have, and create a passage way or pathways for every college with proper roof and shields on it. Plan a space to create bridges that can be used by students and staffs with protection in an inclement weather.
3. Building must have their own bathroom with both male and female with enough supply of water and clear maintenance.
4. Classrooms can have enough space for all courses offered, having their own function areas on which convertible into function rooms for seminar for Students, and as Simulation area.

5. The Computer Laboratory of CBA can be convertible into classroom and staffs rooms if available create more space and expand the building.
6. The school should create to expand the space and bought modern equipment to give the needs of the students in case of emergency.
7. Create student lounge or Common Room for Students; put some equipment that may lead students not feel boredom while waiting for their next class, whereas student must keep and observe silence.
8. Per college can create a small canteen with high maintenance by the students and the college, consider proper ventilation and sanitation.
9. To do so, the organization must provide enough funds to the college to raise the program of renovation and beautification.

REFERENCES

- Ligayaleah Figueroa, Samsung Lim and Jihyun Lee (2016). Investigating the relationship between school facilities and academic achievements through geographically weighted regression, *annals of GIS*, DOI: 10.1080/19475683.2016.1231717 <http://dx.doi.org/10.1080/19475683.2016.1231717>
- Journal of technology and science education (JOTSE)*, 4 (1), 39-47 <http://dx.doi.org/10.3926/jotse.107>
- Palone, Jim (2012). Physical plant and facilities department. Malone University
- Mark Raguindin Limon (2016). The effect of the adequacy of School facilities on students' performance and achievement in technology and livelihood education. www.hrmars.com/journals
- URL: <http://dx.doi.org/10.6007/IJARPED/v5-i1/2058>
- Mohammad A. Hassanian (2020). Quality assessment of a campus Medical Facility: A users approach. <https://www.emerald.com/insight/content/doi/10.1108/IJWHM-01-2020-0001/full/html>
- Khan, Parveen (2012). Role of physical facilities in teaching learning process. *Interdisciplinary journal of Contemporary Research in Business, Pakistan*, ljcrb.webs.com
- Robert Scott Mcgowen (2010). The Impact of School Facilities on Student Achievement, Attendance, Behavior, Completion Rate and Teacher Turnover Rate in Selected Texas High Schools
- Deped (2010). Educational Facilities manual. Pasig City
- Dimakuta, Nexus Alexander Saidar (2015). School Plant and Facilities
- Hezoli, Lovely Ann (2012). Physical plant and Development Program

EMPLOYEE PERFORMANCE APPRAISAL SYSTEM AND ITS RELATION TO INDIVIDUAL PERFORMANCE RATING COMMITMENT: BASIS TO COLLEGE INTERVENTION MEASURED

Ma. Lourdes H. Gomez

INTRODUCTION

The success of any organization depends on the quality and characteristics of its employees. The employees become a significant factor in any organization since they are the heart of the company. Organization simply cannot achieve their goals and objectives without them. However, it is a fact that any employee for that matter needs something to induce them or to look forward to so that they will be motivated to work at the best interest of the company.

This indeed was indicative of the more work according to the HRM (Human Resource Management) Policies which sought to connect the aims of the organizations to the performance of the individual.

The implications of all appraisal and job performance and suitability assessment to ensure the training and materials for appraisal reflect current employment law. Normally performance appraisal has been restricted to a feedback process between employees and supervisors nor managers. Performance appraisals also establish individual training needs and enable organization to identify training need analysis and planning. The institution or the company itself needs to evaluate programs performance to achieve justice and equality among employees, personnel/staff. The process of measuring and evaluating the performance of important process carried out by HRM (Human Resource Management), through this measurement and evaluation to enable the organization to judge the accuracy of the programs and policies adopted, whether policies to attract and selection and appointment or programs and policies for training development and follow up their HR. Employee performance appraisal system regarding about those employees need to conduct this which employees need to improve and need to enhance regards on their duties and responsibilities. This evaluation is important because it will determine the result of the individual employee performance according to their job performance and how they do their job right with efficiency and affectivity.

The issues regarding employee's performance appraisal system that faces of some company are commitment which focus on their duties and responsibilities to their job and next in skills which emphasizes relationship or the behavior of the employee, master or expertise and their functional skills, and finally the last issues regarding on how appraisal system will be effective or not.

The purpose of the study will revisit the criteria set forth in their current appraisal system in order to address the gaps that were identified by the employees. Effective reward system is strongly recommended in order to motivate the employees to work in the best interest of the staff and the company itself as a whole.

STATEMENT OF THE PROBLEM

This study aimed the status to determine the employee performance appraisal system and processes in CBPA faculty.

Specifically, this study sought to answer to the following sub-problems.

1. How do the faculty, administrators and students assess the individual performance rating commitment in terms of:
 - 1.1 Commitment;
 - 1.2 Knowledge of the Subject;
 - 1.3 Teaching for independent learning; and
 - 1.4 Management of learning?

2. Is there significant relationship between the performance of the faculty and the employee performance appraisal system?

3. Is there significant difference on individual performance rating commitment as assessed by faculty, administrators and students?

CONCEPTUAL FRAMEWORK

For the vast majority of organization, Employee performance appraisal system is essential for the effectiveness of this process. The study which will attempt to determine the practices of employee performance appraisal system as a model will be guided by the following paradigm based on the input, process and output model of the system approach as reflected on Figure 1.

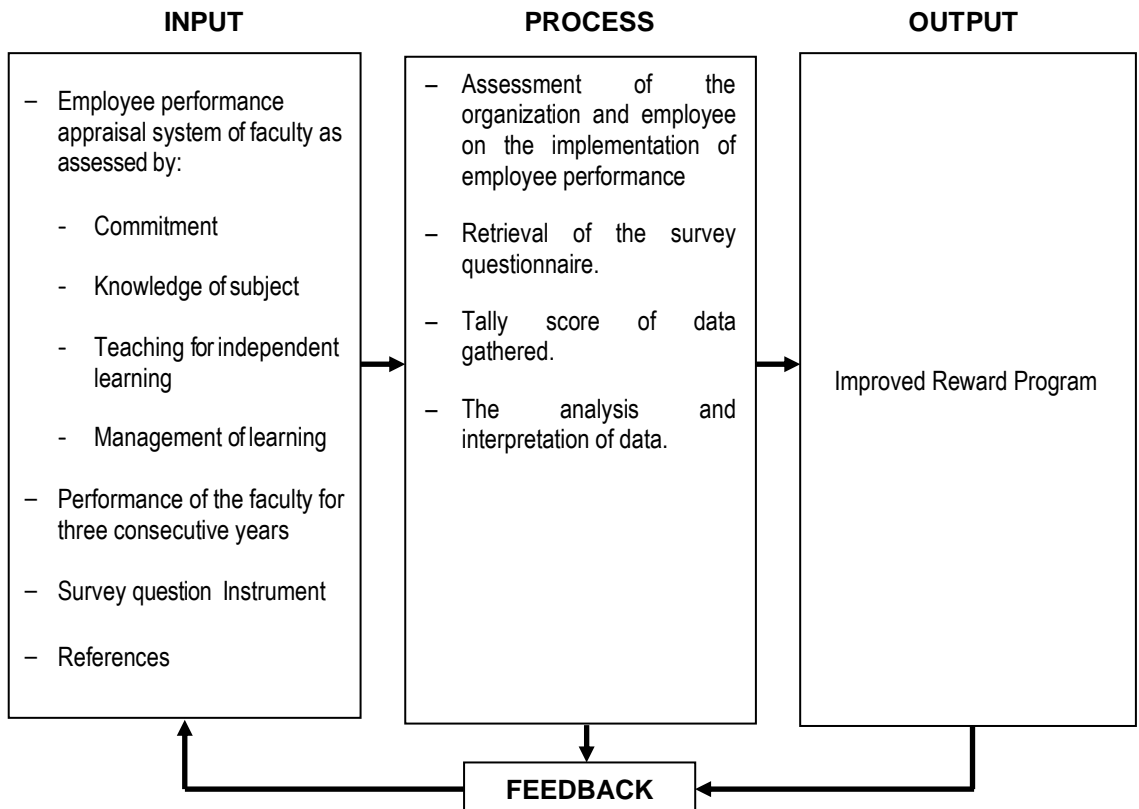

Figure 1. Conceptual Paradigm of the study

The input box consists of the faculty for three consecutive years and the faculty as assessed by commitment, knowledge of subject, teaching for independent learning and management of learning.

The process box includes the retrieval of the survey questionnaire, the tally score of data gathered, analysis and interpretation of data and the assessment of the organization and employee on the implementation of employee performance appraisal system.

Finally, the output box is practices of employee performance appraisal system to improved reward program in an organization

METHODOLOGY

Research Design

This study used both the historical research or historiography and Descriptive research design. Historical research, also known as historiography, the purpose of this research is to collect, verify, and synthesize evidence from the past to establish facts that defend or disprove a hypothesis.

Population and Sampling

Adi Bhat (2018) cluster sampling as a sampling method where multiple clusters of people are created from a population where they are indicative of homogeneous characteristics and have an equal chance of being a part of the sample. In this sampling method, a simple random sample is created from the different clusters in the population. The cluster sampling procedure observed in the selection of the respondents since CBA Students are utilized to answer the questionnaires it needs to be separated and divide it by subgroups according to their courses.

There was a total of 135 all year student-respondents who rated the 20 faculty/ Professors. Each Professor was evaluated by randomly selected Students through the use of simple random scheme all the classes of College of Business Administration.

Table 1
Respondents of the Study

Respondent	f	%
School Administrators	9	5.49
Faculty	20	12.20
Students	135	82.32
Total	164	100.00

As portrayed in the Table 1, it is composed of Three (3) selected groups of respondents such as: 135 or 82.31 percentage of CBA student all years and 20 or 12.19 percentage are Faculty member and 9 or 5.50 percentage are Administrative.

Table 2
Respondents as to Gender

Indicator	School Administrators		Faculty		Students		Total	
	f	%	f	%	f	%	F	%
Male	3	33.33	7	35.00	45	33.33	55	33.54
Female	6	66.67	13	65.00	90	66.67	109	66.46
Total	9	100.00	20	100.00	135	100.00	164	100.00

As identified in the Table 2, the distribution of CBA Students as to gender is as follows: 45 or 33.33 percent are Male, 90 or 66.67 percent are Female.

Research Instrument

The main instrument used in the study was the structured questionnaire in the form of a checklist, which was made by the researchers.

The questionnaire consists of the faculty assessment for three consecutive years which will identify the performance rating of the faculty for the previous years.

Draft of the questionnaire was presented to the research professor and thesis panelists for validation.

Data Gathering Procedures

There are phases in the gathering of data for this study.

1. Create a letter, a letter of permission to be submitted and approved by the College dean in conducting a survey.
2. Conduct our survey right away to the selected respondents after the College Dean approved our letter.
3. Retrieved and tabulate all data gathered according to the questionnaire after conducting the survey.
4. Analyze and interpret the result of data gathered
5. Prepare for the oral presentation.

Statistical Treatment of Data

This study utilized Microsoft Excel 2010 specifically the use of frequency count, percentages, and mean as statistical tools in determining the level of professionalism, commitment, knowledge of the subject, teaching for independent learning, and management of learning.

The data collected in the study were organized and classified based on the research design and problems formulated. The data were coded, tallied, tabulated, and tabled to facilitate the presentation and interpretation of results using the following:

1. **Frequency.** It is the actual response to a specific item/question in the questionnaire where the respondent ticks his choice.

2. **Percentage.** To determine the relations of a part to a whole.

$$\text{Formula: } P = f \times \frac{100}{N}$$

Where:

f	=	Frequency
N	=	Number of Cases
P	=	Percentage

3. **Weighted Mean.** It is the sum of the item values divided by the total number of items. It is computed average and its magnitude is influenced by every one of the item values in the set, and used to describe as set of quantitative data provided the item values that constitute the set are considerably concentrated. It is computed by adding and dividing the sum by the total number of scores.

$$\text{Formula: } WM = \frac{\Sigma(w_1f_1 + w_2f_2 \dots + w_nf_n)}{N}$$

Where:

WM	=	Weighted Mean
f ₁	=	frequency of first cell
w ₁	=	weight of first cell
f ₂	=	frequency of second cell
w ₂	=	weight of second cell
N	=	number of cases

4. **Likert Scale.** The data is interpreted by using the Five (5) Likert Scale Method, as the criterion which serves as the basis for the interpretation of the data. The concept of the boundary of the numerals will be used as follows:

Individual Performance Rating Commitment a scale with description

Weight	Rating Scale	Descriptive Rating
5	4.21 – 5.00	Outstanding
4	3.41 – 4.200	Very Satisfactory
3	2.61 – 3.40	Satisfactory
2	1.81 – 2.60	Fair
1	1.00 – 1.80	Poor

5. **Ranking.** This was used to determine the order of decreasing or increasing magnitude of variations. The largest frequency is ranked number 1, 2 and so on down to the last rank and number.

Sub-problem No. 1: How do the school administrators, faculty; and students assess the individual performance rating in terms of:

1.1 Commitment

Table 3
Individual Performance Rating As to Commitment

Indicator	School Administrators		Faculty		Students		Composite		Rank
	WM	VI	WM	VI	WM	VI	WM	VI	
1. Provide excellent service through workplace.	4.44	O	4.75	O	4.14	VS	4.44	O	2
2. Encourage creative and innovative information to meet quality services.	4.44	O	4.75	O	4.11	VS	4.43	O	3
3. Conducts great deal of extra effort to help the Organization to be successful.	4.89	O	4.85	O	4.23	O	4.66	O	1
4. Regularly meet concerned to the individuals life goals should be work oriented.	4.22	O	4.85	O	4.04	VS	4.37	O	5
5. Communicates broad to all and shares information with the concerned of organization and considering their adaptability through the improvement of the work.	4.22	O	4.85	O	4.13	VS	4.40	O	4
Overall Weighted Mean	4.44	O	4.81	O	4.13	VS	4.46	O	

As manifested in Table 3, the assessment on the individual performance rating as to groups of respondents' assessments on the individual performance rating as to commitment are as follows: faculty rated as Outstanding with overall weighted mean of 4.81; school administrators rated as Outstanding with overall weighted mean of 4.44; and students rated as Very Satisfactory with overall weighted mean of 4.13.

In support to the findings, Ang & Rabo determine that the increase of employee engagement relationship in terms of Commitment is increase in vice versa in order to treated the mediating variables between engagement and job satisfaction as well the organization commitment.

1.2 Knowledge of the Subject

As depicted in Table 4, the assessment on the individual performance rating as to knowledge of the subject rated as Outstanding with overall weighted mean of 4.42. All items rated as Outstanding, such as: explains the relevance of present topics to the previous lessons and relates the subject matter to relevant current issues and/or daily life activities; demonstrates up to date knowledge and/or awareness on current trends and issues of the subject; integrates subject to practical circumstances and learning intents/purposes of students; Demonstrate mastery of the subject matter (explain the subject matter without relying solely on the prescribed text-book); and draws and share information on the state on the art of theory and practice in his/her discipline.

Table 4
Individual Performance Rating As to Knowledge of the Subject

Indicator	School Administrators		Faculty		Students		Composite		Rank
	WM	VI	WM	VI	WM	VI	WM	VI	
1. Demonstrate mastery of the subject matter (explain the subject matter without relying solely on the prescribed text-book).	4.44	0	4.75	0	4.05	VS	4.41	0	4
2. Draws and share information on the state on the art of theory and practice in his/her discipline.	4.33	0	4.85	0	4.01	VS	4.40	0	5
3. Integrates subject to practical circumstances and learning intents/purposes of students.	4.44	0	4.85	0	3.96	VS	4.42	0	3
4. Explains the relevance of present topics to the previous lessons and relates the subject matter to relevant current issues and/or daily life activities.	4.44	0	4.80	0	4.12	VS	4.45	0	1
5. Demonstrates up to date knowledge and/or awareness on current trends and issues of the subject.	4.44	0	4.75	0	4.10	VS	4.43	0	2
Overall Weighted Mean	4.42	0	4.80	0	4.05	VS	4.42	0	

As to groups of respondents' assessments on the individual performance rating as to knowledge of the subject are as follows: faculty rated as Outstanding with overall weighted mean of 4.80; school administrators rated as Outstanding with overall weighted mean of 4.42; and students rated as Very Satisfactory with overall weighted mean of 4.05.

In relation to the result of the study, Pilarta (2015), the student achievement and teacher performance are based on the educational qualification and standard, technical preparedness, supervision and etc. and it is also the key factors to work performance in teaching profession.

1.3 Teaching for Independent Learning

As shown in Table 5, the assessment on the individual performance rating as to teaching for independent learning rated as Outstanding with overall weighted mean of 4.45. All items rated as Outstanding, these are: encourages students to learn beyond what is required and help / guide the students how to apply the concepts learned with composite weighted mean of 4.47 as rank 1; creates teaching strategies that allow students to practice using concepts they need to understand (interactive discussion); and enhances student self-esteem and / or gives due recognition to student's performance / potentials with both composite weighted mean of 4.46 as rank 2 and 3; allows students to think independently and make their own decisions and holding them accountable for their performance based largely on their success in executing decisions with composite weighted mean of 4.45 as rank 4; and allows students to create their own course with objectives and realistically defined student professor rules and make them accountable for their performance with composite weighted mean of 4.42 as rank 5.

Table 5
Individual Performance Rating As to Teaching for Independent Learning

Indicator	School Administrators		Faculty		Students		Composite		Rank
	WM	VI	WM	VI	WM	VI	WM	VI	
1. Creates teaching strategies that allow students to practice using concepts they need to understand (interactive discussion).	4.56	O	4.75	O	4.06	VS	4.46	O	2.5
2. Enhances student self-esteem and /or gives due recognition to student's performance/potentials.	4.44	O	4.80	O	4.13	VS	4.46	O	2.5
3. Allows students to create their own course with objectives and realistically defined student professor rules and make them accountable for their performance.	4.56	O	4.70	O	4.01	VS	4.42	O	5
4. Allows students to think independently and make their own decisions and holding them accountable for their performance based largely on their success in executing decisions.	4.44	O	4.80	O	4.12	VS	4.45	O	4
5. Encourages students to learn beyond what is required and help/guide the students how to apply the concepts learned.	4.44	O	4.80	O	4.16	VS	4.47	O	1
Overall Weighted Mean	4.49	O	4.77	O	4.09	VS	4.45	O	

As to groups of respondents' assessments on the individual performance rating as to teaching for independent learning are as follows: faculty rated as Outstanding with overall weighted mean of 4.77; school administrators rated as Outstanding with overall weighted mean of 4.49; and students rated as Very Satisfactory with overall weighted mean of 4.09.

A study done by Legazpi (2015) that performance evaluation of the part-time and permanent are based on instructional method and independent learning of the faculty member of the school.

1.4 Management of Learning

As revealed in Table 6, the assessment on the individual performance rating as to management of learning rated as Outstanding with overall weighted mean of 4.30. Three (4) items rated as Outstanding, namely: use of instructional materials (audio/video materials; field trips, film showing, computer aided instruction, etc.) to reinforce learning processes with composite weighted mean of 4.49 as rank 1; creates opportunities for intensive and / or extensive contribution of students in the class activities (e.g. breaks class into dyads, triad or buzz / task group) with composite weighted mean of 4.37 as rank 2; and assumes roles as facilitator, resource person, coach, inquisitor, integrator, referee in drawing students to contribute to knowing edge and understanding of the concepts of hands with composite weighted mean of

4.31 as rank 3 and designs and implements learning conditions and experience that promotes healthy exchange and / or confrontations with composite weighted mean of 4.19 as rank 4; and One (1) items rated as Very Satisfactory, such as: structure/re-structures learning and teaching-learning context to enhance attainment of collective learning objectives with composite weighted mean of 4.12 as rank 5.

Table 6
Individual Performance Rating As to Management of Learning

Indicator	School Administrators		Faculty		Students		Composite		Rank
	WM	VI	WM	VI	WM	VI	WM	VI	
1. Creates opportunities for intensive and/or extensive contribution of students in the class activities (e.g. breaks class into dyads, triad or buzz/task group).	4.22	O	4.75	O	4.15	VS	4.37	O	2
2. Assumes roles as facilitator, resource person, coach, inquisitor, integrator, referee in drawing students to contribute to knowing edge and understanding of the concepts of hands.	4.22	O	4.70	O	4.00	VS	4.31	O	3
3. Designs and implements learning conditions and experience that promotes healthy exchange and/or confrontations.	4.22	O	4.30	O	4.05	VS	4.19	O	4
4. Structure/re-structures learning and teaching- learning context to enhance attainment of collective learning objectives.	4.11	VS	4.25	O	4.00	VS	4.12	VS	5
5. Use of instructional materials (audio/video materials; field trips, film showing, computer aided instruction, etc.) to reinforce learning processes	4.44	O	4.85	O	4.19	VS	4.49	O	1
Overall Weighted Mean	4.24	O	4.57	O	4.08	VS	4.30	O	

As to groups of respondents' assessments on the individual performance rating as to management of learning are as follows: faculty rated as Outstanding with overall weighted mean of 4.57; school administrators rated as Outstanding with overall weighted mean of 4.24; and students rated as Very Satisfactory with overall weighted mean of 4.08.

Relatively, Noe (2019) determine that an employee and employer relationship influencing training and development practices on how management of learning be more competitive as well the collaboration of companies.

Table 7
Summary of the Individual Performance Rating

Indicator	School Administrators		Faculty		Students		Composite		Rank
	WM	VI	WM	VI	WM	WM	VI	WM	
1. Commitment	4.44	O	4.81	O	4.13	VS	4.46	O	1
2. Knowledge of the Subject	4.42	O	4.80	O	4.05	VS	4.42	O	3
3. Teaching for Independent Learning	4.49	O	4.77	O	4.09	VS	4.45	O	2
4. Management of Learning	4.24	O	4.57	O	4.08	VS	4.30	O	4
Grand Mean	4.40	O	4.74	O	4.09	VS	4.41	O	

Table 7 summarizes the assessment on the individual performance rating rated as Outstanding with the grand mean of 4.41. All items rated as Outstanding, these are: commitment with composite weighted mean of 4.46 as rank 1; teaching for independent learning with composite weighted mean of 4.45 as rank 2; knowledge of the subject with composite weighted mean of 4.42 as rank 3; and management of learning with composite weighted mean of 4.30 as rank 4.

Generally, the groups of respondents' assessments on the individual performance rating are as follows: faculty rated as Outstanding with the grand mean of 4.74; school administrators rated as Outstanding with the grand mean of 4.40; and students rated as Very Satisfactory with the grand mean of 4.09.

Sub-problem No. 2: Is there a significant relationship among individual performance rating?

Table 8
Comparative Relationship of the Individual Performance Rating

Df	Critical value	Chi-square value	Interpretation	Decision
162	171.79	0.005383	Not Significant	Accept H0

As depicted in Table 8, the computed Chi-square is 0.005383 which is lower than the critical value of 171.79 with 162 degree of freedom. Hence, there is no significant relationship among performance appraisal system namely: commitment, teaching for independent learning, knowledge of the subject, and management of learning. Therefore, the hypothesis is accepted.

Sub-problem No. 3: Is there a significant difference on individual performance rating as assessed by school administrators, faculty, and students?

Table 9
Comparison of the Assessments of the Respondents on the Individual Performance Rating

Indicator	SS	df	MS	Critical F-value	Computed F-value	Int.	Decision
Commitment							
Between Groups	0.23	2	0.11	3.89	0.41178	Not Significant	Accept Ho
Within Groups	3.37	12	0.28				
Knowledge of the Subject							
Between Groups	0.28	2	0.14	3.89	0.5036	Not Significant	Accept Ho
Within Groups	3.36	12	0.28				
Teaching for Independent Learning							
Between Groups	0.22	2	0.11	3.89	0.40809	Not Significant	Accept Ho
Within Groups	3.36	12	0.28				
Management of Learning							
Between Groups	0.12	2	0.06	3.89	0.22332	Not Significant	Accept Ho
Within Groups	3.37	12	0.28				

Level of significance @0.5

As manifested in Table 9, the computed F-values are as follows: commitment (0.41178); knowledge of the subject (0.5036); teaching for independent learning (0.40809); AND management of learning (0.22332) were all lower than the critical values of 3.89 with the degree of freedom of 2 and 12 at 0.5 level of significance. Hence, there is no significant difference on the individual performance rating as assessed by administrators, faculty and students. Therefore, the hypothesis is accepted.

CONCLUSIONS AND RECOMMENDATIONS

Based on the findings of the study, the following conclusions were drawn:

1. The individual performance rating on commitment, teaching for independent learning, knowledge of the subject, and management of learning were found Outstanding.
2. Commitment, teaching for independent learning, knowledge of the subject, and management of learning have distinct among others.
3. Administrators, faculty and students were parallel in the assessment of individual performance rating commitment.

Recommendations

From the foregoing findings and conclusions, the following recommendations are offered:

1. The recommendation for Administrators and Professors to maintain their performance on their job as well continues how they committed to their jobs.
2. The recommendation for administrators continues support professors and students relationships in terms of every course organization that would help the student to grow more.
3. Administrators in their effort to maintain or sustain employee commitment and should look at other variables like reward system, good working environment, leadership and other than employee performance appraisal.

RECORD MANAGEMENT SYSTEM FOR SENIOR CITIZENS IN GENERAL MARIANO ALVAREZ, CAVITE

Eugene Paolo Z. Guades

Catherine D. Dumpit

Gerlyn M. Domingo

INTRODUCTION

Technological advancements in information technology have changed the way records are created, authenticated, and preserved. As electronic documents proliferate, record management becomes ever more important to organizations, large and small.

The technology beginning to gain attention in the document technologies arena is not a new technology at all. It is one of the cornerstones of back-office operations, the record management (RM).

Through this vast changes and development that is happening with our technology today particularly in record management system, the Philippine government introduced the E-Government Master Plan 2022 (EGMP 2022) that is also aligned with the ASEAN ICT Master Plan (AIM) 2020 which envisions a digitally-enabled economy that is secure, sustainable, and transformative; and to enable an innovative, inclusive and integrated ASEAN Community. As the Philippines embraces digital transformation, the initiatives of AIM 2020 seek to facilitate faster access to services and at the same time, develop better ways of doing business among traditional sectors, fostering growth and development towards a digital economy.

Furthermore, it identified in the Philippine Development Plan (PDP) 2022 a strategy to continue to enhance the country's e-government system as a vital tool for good governance. With this, the DICT aspires the Philippines to develop and flourish through innovation and constant development of ICT in the pursuit of a progressive, safe, secured, contented and happy Filipino nation.

At present, people have become more adapted in the modern lifestyle along with the use of computer. It is one of the most powerful machines that help people's lives becomes easier and services more accessible. Hence, the study proposes a system to improve the record management of Senior Citizens in the Office of the Senior Citizens Affairs (OSCA) in the town of General Mariano Alvarez, Cavite. This study proposed to develop a Record Management System for the Office of the Senior Citizens Affairs that will be able to create a module for Registration of Senior Citizen members in the municipality. The system covers up the creation and registration of members based on the credentials needed by the client or the organization itself. It will also create a module for storage of member's credentials in which the information of the senior citizens is securely stored in the database. The proposed system will also provide a module for Allowance Monitoring. The system can monitor allowance issued to the senior citizen officers quarterly and monthly. Lastly, it will make a module for Report Generation. It can generate a list of records of the Senior Citizens according to location in the town and its information, status, annual and monthly report if in case it is needed for assessment.

This topic was chosen for research to help the Office of the Senior Citizens Affairs in handling their transactions and concerns among the senior citizens of the municipality. This will also be able to facilitate an efficient government services among the senior citizen of GMA

Cavite through the utilization of an effective record management system. Most importantly, this study can help improve their work and make it more easy and accessible not only for the personnel that will utilized it but for the senior citizens as well.

METHODOLOGY

The researcher used the descriptive-developmental type of research in assessing the content, efficiency, functionality and usability of the Record Management System for Senior Citizens in General Mariano Alvarez, Cavite. According to Jackson (2009), the descriptive method of research is that the respondents answer the questions administered through survey questionnaires and researchers interpret the collected data. Furthermore, the proponent will implement Agile Based Web Development Model, incremental delivery of software applications allow to manage the change. Using the available requirements the developers may develop a web application and release the first increment. Then the additional requirements are incorporated to the first release and the next increment is released and so on. This process may go on indefinitely because of the frequent changes in requirements. (Shiny Angel,2016)

RESULTS AND DISCUSSION

1. Is there a record management system for the Office of the Senior Citizens Affairs (OSCA)?

The evaluation shows that there is no record management system at the Office of the Senior Citizens Affairs (OSCA).

2. What Management System for Office Senior Citizens Affairs maybe developed?

The figure shows the login form for the OSCA Record Management System. This form will require a username and password in order to validate the user that will use the system.



In the figure below shows the form where you can add a record of the senior citizen for profiling. This includes the needed personal information and image of the senior citizen.

Add Profile

Date of Birth: 1946-08-23 S.C. Number: 19-0004 No. 4

Date: 12-10-2019 Age: 73 Gender: Male

Address: Bik. [] Lot [] Street []

Village: [] Barangay: []

Full Address: []

First Name: [] Middle Name: [] Maiden Name: N/A

Surname: [] Pensions: []

Place of Birth: [] REMARKS: []

Civil Status: [] Occupation: []

Contact Number: []

[Camera] [Browse]

[ADD] [CLEAR ALL]

The figure below shows the Home form where you can view the number of senior citizens residing throughout the town of General Mariano Alvarez and its corresponding barangays. It also shows how many are PWDs, have pensions and is sorted also by gender.

Office of the Senior Citizens Affairs Record Management System - General Mariano Alvarez, Cavite

Home Profiles Reports Help SMS admin Log out

Senior Citizens Population by Barangay

ALDIANO OLAES	0	GREGORIA DE JESUS	0
BRGY. POBLACION 1	0	INOCENCIO SALUD	0
BRGY. POBLACION 2	0	JACINTO LUMBRERAS	0
BRGY. POBLACION 3	0	KAPITAN KUA	1
BRGY. POBLACION 4	0	KORONEL JOSE P. ELISES	0
BRGY. POBLACION 5	0	MACARIO DACON	0
BENJAMIN TIRONA	0	MARCELINO MEMIJE	0
BERNARDO PULIDO	0	NICOLASA VIRATA	0
EPIFANIO MALIA	0	PANTALEON GRANADOS	0
FRANCISCO DE CASTRO	0	RAMON CRUZ	0
FRANCISCO REYES	0	SAN GABRIEL	2
FLORELIO CALIMAG	1		
GAVINO MADERAN	0		

SENIOR CITIZENS

Total Population: **4**

Pensions:

- Social Pension: 0
- SSS: 0
- GSIS: 0
- PVAO: 0

MALE: **3** FEMALE: **1** PWD: **0**

Date: 02-06-2020 Time: 11:44:44

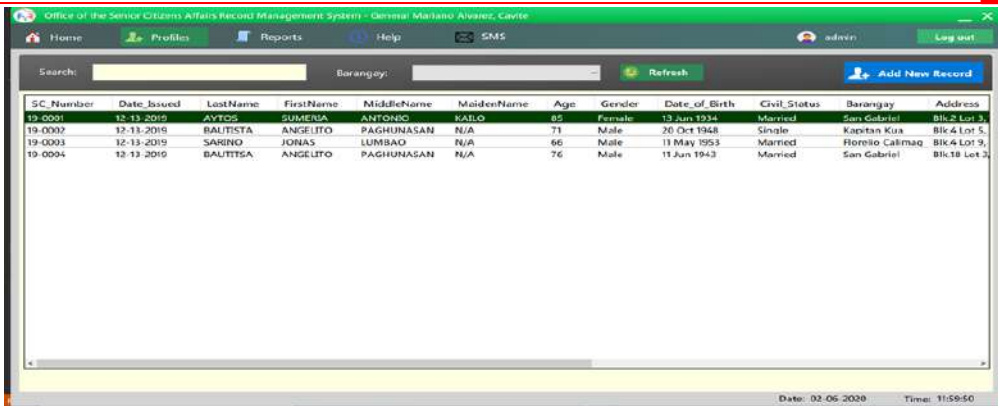

It shows the SMS form where you can text the specified senior citizen for announcements, birthday greetings and their monthly allowance. You can manually type the number of the recipient or get the contact number from the displayed table on the right. It also includes buttons for pre-formatted messages for less manual texting.

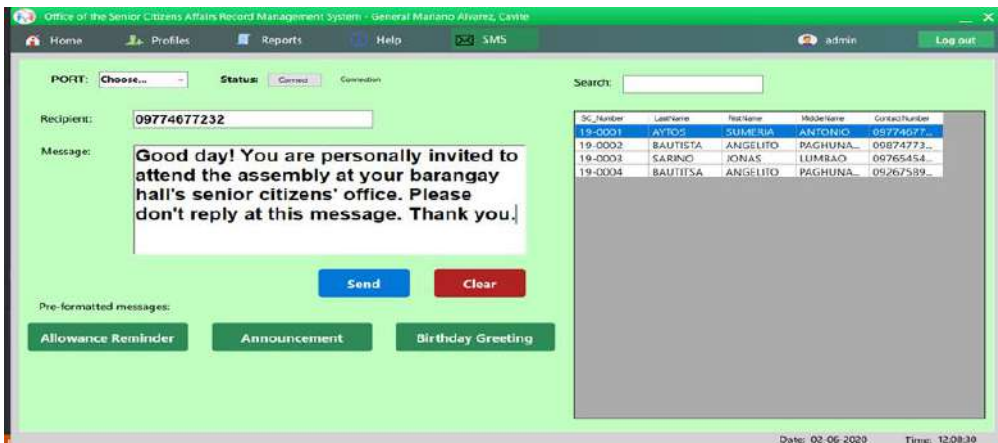

Help Options

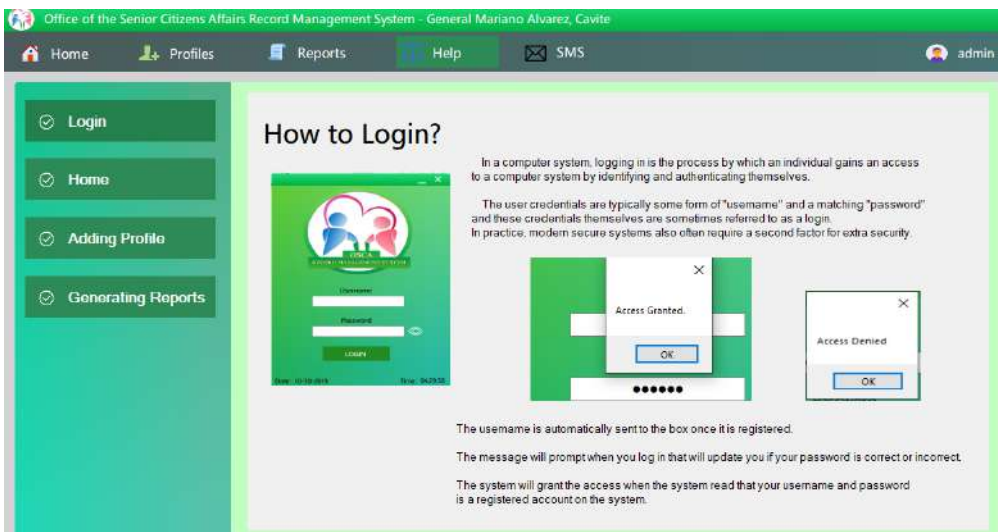

3. How does the system performs in terms of:
 - 3.1 Effectiveness;
 - 3.2 Efficiency;
 - 3.3 User Interface Design;
 - 3.4 Flexibility;
 - 3.5 Accuracy;
 - 3.6 Security; and
 - 3.7 Help Options?

Criteria	Student	IT Expert	End User	Sub Mean	Adjective Meaning	Rank
1.) Effectiveness	4.14	3.43	3.7	3.75	VA	4
2.) Efficiency	4.22	3.35	3.73	3.76	VA	3
3.) User Interface Design	4.2	3.34	3.81	3.78	VA	2
4.) Flexibility	4.22	3.13	3.8	3.71	VA	5
5.) Accuracy	4.23	3.03	3.57	3.61	VA	7
6.) Security	4.31	3.13	3.93	3.79	VA	1
7.) Help Options	4.27	3.17	3.63	3.69	VA	6
Weight mean average	4.23	3.23	3.74	3.73	VA	

The table displays the summary of the evaluation that presents different criteria that are evaluated by End Users, IT Experts and Students. Security got 3.79 as the highest rating given by the evaluators; User interface design ($x=3.78$); Efficiency ($x=3.76$); Effectiveness ($x=3.75$); Flexibility ($x=3.71$); Help Options ($x=3.69$); and Accuracy ($x=3.61$). Overall, the system is very acceptable with weighted mean average of 3.73.

CONCLUSION

1. The research found out that there was no records management system at the Office of the Senior Citizens Affairs (OSCA)
2. The develop system provides a computerized record management system for the Office of the Senior Citizens Affairs.
3. The assessment of the respondents of the developed OSCA Record Management System is very acceptable. The researchers concluded that the system increase the productivity and minimize the work of managing the documents and the records.

RECOMMENDATIONS

1. OSCA Record Management System is very acceptable to be used by the Office of the Senior Citizens Affairs Office specifically by the President as the administrator and the office workers as their primary system for storing and handling records of the senior citizens.

2. The researchers recommend hiring a permanent records staff that will be responsible for operating and maintaining the new processes needed.

3. The researcher recommends all relevant staff and employees to be thoroughly skilled and undergo training and workshop for the utilization of the new system.

4. This study also recommends for the future developers, that Senior Citizens office must also have online platforms and must develop online services to be more accessible for senior citizen especially with those of with comorbidities and health conditions and to prevent further risks such as accidents and the emergence of communicable diseases.

REFERENCES

- Azlina A. A., Yusof Z. M. 2019. Electronic Document and Records Management System (EDRMS) Adoption in Public Sector – Instrument's Content Validation Using Content Validation Ratio (CVR). <https://iopscience.iop.org/article/10.1088/1742-6596/1196/1/012057/meta>
- Kasumba Geoffrey. 2013. Designing An Effective Records Management System A Case Study Of (5) The Economic Policy Research Center (EPRC) Uganda. 10.13140/RG.2.2.35178.67522
- <https://dict.gov.ph/ictstatistics/wp-content/uploads/2020/03/EGMP-2022.pdf>
- <https://searchcompliance.techtarget.com/definition/records-management>
- <https://archives.un.org/content/understanding-records-management#:~:text=Records%20management%20is%20the%20efficient,in%20the%20form%20of%20records.>
- <https://digitalcommons.usu.edu/cgi/viewcontent.cgi?article=3147&context=etd>

A STUDY ON PARENTS PERSPECTIVE ON TREATMENT OF CHILDREN UNDER INVESTIGATION FOR VIOLATION OF ORDINANCE

*Felipe K. Jamero
Richard K. Jamero
Romeo B. Capucan
Derick O. Peralta
Roger D. Ramos*

INTRODUCTION

Children are vulnerable to all sorts of social, psychological, emotional, and physical harassment that the law provides of care and protection. (Loeber and Stouthamer-Loeber, 1987) identifies the area of vulnerability of a child namely; aggression, stealing, truancy, lying, drug use—are not only general predictors of delinquency many years later, but especially of serious delinquency, and in certain cases, of recidivism. With the advent of technology, sex offenders are capable to find a victim from where it is, time, and country. The handling of child delinquencies is so crucial that mismanagement from investigation to handling over to authorities may have lasting effect to the child.

The figures from the Philippine National Police showed a total of 2,158 cases involving underage offenders which were reported to the PNP Women and Children Protection Center. Half of them have theft cases committed from January to December of 2008. Crimes involving minors rose by 18%. Cases of drug use also rose from 113 in 2007 to 145 in 2008. This means that there is an increase at about 28% (Quismundo, 2009).

According to Bocar (2014) common factors of juvenile delinquencies are classified from that of family, environment, school and other department or agencies of the government. Needless to say, the Sanguniang Barangay has a vital role to play in the enforcement of laws, protection of people, and preservation of peace. Republic Act 9262 of the Violence Against Women and Children Act is a noble law that not protects the victims from various forms of abuse but also the children's vulnerability to various exploitative designs. The intent of the law is to guide various departments, instrumentalities, and bureau on child protection and to safeguard their welfare.

Republic Act 8369 provide a family court to try issues and legal concern to safeguard the rights and welfare of the children from various exploitative conditions. The state as *parens patriae*, through its protective mantle and utilization of available resources, has the primordial authority to impose these laws through the aid of various instrumentalities of the government.

METHODOLOGY

The researchers employed a research survey questionnaire to students and directed them to give a copy to their parents, and guardian upon completion should return to the researcher for data collation and interpretation to come up with findings, interpretation of the responses.

The parents or guardians of the researcher's students are the participants in the study, questions written, and instructions provided on how question shall be answered, the choices they are to check, and item rankings concerning offenses committed by children in the barangay.

The Survey Method questionnaire is the primary source of data. Each Students are given a copy of the questionnaire for their parents. Within one to two weeks, depending on the parents' speed of answering, the questionnaire should be returned to their children. It was submitted to the research for collation tabulation.

This study utilizes the Likert Scale approach with 4-point choices, weighted mean for respondents' profile, and item ranking.

Aim/Purpose

The process is stipulated in the local government code, particularly on the lupon nang tagapamayapa on its performance of the investigation in their respective communities. Further, the violence against women and their children act (RA 9262) provides a guide on the manner of investigation, treatment and handling of children to avoid traumatic experience that affects the well-being of the child and task appropriate agencies on providing professional care and assistance.

This study crafted a survey questionnaire based on RA 9262 on handling the investigation of a child violator that the barangay should observe where respondents were requested to answer. High School parents were asked to answer the questions under study, and the researchers collated, treated, and interpreted the results from the survey questionnaire.

Statement of the Problem

1. Are the processes observed in the investigation of a child per the letters of RA 9262?
2. What are the common infractions children incurred in the Barangay?
3. From the parents' perspective, what are the appropriate penalties the authorities should impose on a child violator?
4. Are parents supportive of a law lowering the age of criminal liability?

Findings

Table 1
Educational Attainment

Educational Attainment	Frequency	Percent	Valid Percent	Cumulative Percent
Elementary	4	5.3	5.3	5.3
High School	50	65.8	65.8	71.1
College	22	28.9	28.9	100.0
Total	76	100.0	100.0	

Table 1 present the educational attainment of parent respondents, 50 or 65.8% of them are of high school graduates, 4 or 5.3% are elementary graduates, and 22 or 28.9% are college degree earner. The data shows that the majority of parent respondents are high school graduates.

Table 2
Sex

Sex	Frequency	Percent	Valid Percent	Cumulative Percent
Male	28	36.8	36.8	36.8
Female	48	63.2	63.2	100.0
Total	76	100.0	100.0	

Table 2 presents that 48 or 63.2% are female while 28 or 36.8% are male parent respondents according to sex.

Table 3
Age

Age	Frequency	Percent	Valid Percent	Cumulative Percent
below 25	7	9.2	9.2	9.2
26-31	6	7.9	7.9	17.1
32-36	15	19.7	19.7	36.8
37-40	15	19.7	19.7	56.6
41-46	14	18.4	18.4	75.0
47-51	4	5.3	5.3	80.3
52-56	7	9.2	9.2	89.5
57-over	8	10.5	10.5	100.0
Total	76	100.0	100.0	

Table 3 present the age of parent respondents. The majority of the parent respondents are from age ranges of 32-36; and 37-40, with 15 or 19.7%. Followed by 41-46 with 14 or 18.4% of the total parent respondent population. 8 or 10.5% are of 57-over years old of the parent respondent's population. Parent respondents are in their early and mid-adult age range.

Table 4
Work

Work	Frequency	Percent	Valid Percent	Cumulative Percent
Yes	43	56.6	56.6	56.6
No	33	43.4	43.4	100.0
Total	76	100.0	100.0	

Table 4 present that 43 or 56.6% of the parent respondents has worked, and 33 or 43.4% are not.

Table 5
If Yes

If Yes	Frequency	Percent	Valid Percent	Cumulative Percent
Public	20	26.3	47.6	47.6
Private	22	28.9	52.4	100.0
Total	42	55.3	100.0	
System	34	44.7		
Total	76	100.0		

Table 5 shows that parent respondents have worked in the private sector with 22 or 28.9% while 20 or 26.3% are in the public sector.

Table 6
Number of Children

Number of Children	Frequency	Percent	Valid Percent	Cumulative Percent
1 to 3	39	51.3	51.3	51.3
4 to 6	29	38.2	38.2	89.5
7 up	8	10.5	10.5	100.0
Total	76	100.0	100.0	

Table 6 data shows that parent respondents 39 or 51.3% have 1 to 3 children, while 29 or 38.2% of them have 4 to 6 children. The remaining parent respondents have 7 or more children, with 8 or 10.5% of the parent respondent's population.

Table 7

Based on your knowledge and experience, please answer the following

Choice 1. Done Properly

Choice 2. Observed but improper

Choice 3. Did not observed

Choice 4. No Such Process

Procedures	1	%	2	%	3	%	4	%	total	%
1. Ipinapaliwanag sa bata sa lengwahe na kanyang naiintindihan ang kanyang nagawa at kung bakit sya inimbestigahan	58	76.3	12	16	0	0	6	7.9	76	100
(A child under investigation is informed in a language they comprehend and why there is an investigation.)										

2. Ang bata ay sinasabihan at pinapayuhan. Ipinapaalam sa bata ang karapatan nito sa ilalim ng Konstitusyon. (The child is informed and advised of his rights)	51	67.1	20	26	2	3	3	3.9	76	100
3. Nagpapakilala ang nagsasagawa ng pag-iimbistiga at nagpapakita ng mga ID o anumang papeles para patunayan ang kanyang tungkulin sa pagsasagawa ng imbestigasyon sa bata. (The person conducting investigation presents identification or papers to show they are authorized to investigate the child.)	50	65.8	11	15	5	7	10	13.2	76	100
4. Ang nag-iimbistiga ay naiwas sa paggamit ng hindi naaayon pananalita tulad ng pagmumura, pananakit o pangaabusong sekswal sa batang kinakausap o inimbestigahan. (The investigator avoids the use of illicit word, harass, inflict harm or sexually abuse a child when investigating)	36	47.4	21	28	8	11	11	14.5	76	100
5. Iniiwasan magpakita ng posas, pamalo, baton, baril o anumang uri nang kagamitang tulad nito sa tuwing kinakausap ang bata na inimbestigihan. (Investigators avoids showing handcuffs, batons, sticks, guns o any instrument that may inflict harm when investigating a child)	35	46.1	20	26	8	11	13	17.1	76	100
6. Iniiwasang gumamit na hindi kailangang pwersa tulad ng paghawak, pagposas o pagtali sa batang nakagawa ng paglabag sa batas o ordinansa. Maliban na lang kung kailangan ayon sa sitwasyon. (Avoid the use of unnecessary force like handcuffing, grappling, and tying a child that had violated an ordinance unless the circumstances warrant)	38	50	13	17	13	17	12	15.8	76	100
7. Inaalang ng nag-iimbistiga ang tunay na edad na batang kinakausap sa simula ng imbestigasyon. (The investigator determines the actual age of the child when conducting inquiry)	54	71.1	13	17	4	5	5	6.6	76	100
8. Kung ang bata ay nakagawa ng paglabag kinakausap at ipinapaalam sa magulang ang nagawa at nararapat na parusa sa kanya. Sa loob ng 8 oras, pagkatapos na ito ay mahuli ng barangay at umaamin sa nagawa ay agad na inilalagay sa kustodiya ng Social Welfare Development officer o anumang kahalintulad nito ang bata at kinakausap ang mga magulang sa magiging proseso ng rehabilitasyon, kustodiya at obligasyon ng mga magulang sa panahon nasa pangangalaga ito ng ahensya o bureau na may sakop sa batang nagkasala.	53	69.7	7	9.2	6	8	10	13.2	76	100

(If a child committed an infraction, parents are informed of the offense and the penalty that the law imposes. Within 8 hours upon accosted by the barangay officials and the child violator admitted to the infraction, it immediately turns over to the custody of the Social Welfare Development Officer or any authorized government agency or institution that may provide professional care and assessment. Parents are informed on the process and their obligations)										
9. Kaagad na sinusuri ang bata sa kanyang pisikal at mental na kalagayan. (The child is immediately asses on its physical and mental state.)	53	69.7	14	18	4	5	5	6.6	76	100
10. Ang mga batang may pagkakasala ay inilalagay sa isang arresting area at inihihawalay ayon sa kanilang kasarian at sa mga may edad nang nakaipit. (Child violators arresting area segregated according to their sex and age from that of adult offenders)	50	65.8	13	17	5	7	8	10.5	76	100
11. Kung ang bata ay umamin sa kanyang nagawa agad na kinakausap ang magulang sa mga epekto nito sa bata at sa mga prosesong kakaharapin tulad ng pagbibigay sa isang social worker o institution na siyang may kapangyarihan irehabilitate ang bata upang maisaayos at itama ang mga nagawang pagkakamali. Limitasyon ng magulang sa bata sa panahon ng rehabilitasyon at iba pang tulad nito. (If a child admitted an offense. The parents are informed of the legal processes and the institutions or government agencies charged with the care of the child violator. Informed of the rehabilitation process and civil limitation of the parents during the reformation.)	56	73.7	8	10.5	4	5.3	8	10.5	76	100

Table 7 present the parent respondents' perceptions of the processes under the RA 9262. Choice 1 represents that the process is done properly; Choice 2 Observed but improper; Choice 3 Did not Observe; Choice 4 No Such Process.

Most of them agreed that all of these procedures were done properly by barangay officials in handling a child under investigation for violation of an ordinance. Question 6, as observed, reflects that parent respondents that barangay officials confirm with the procedures; 38 respondents are differing in their opinion while the majority is evenly dispensed on their observation on this matter. Question 1 received the highest affirmation with 58 or 78.1% viewed that the barangay officials are properly observing this procedure, followed by Question 7 with 54 or 71.1% also affirming that barangay officials are properly keeping this procedure.

The parent respondents viewed the rest of the procedures within Choice 1 as affirmation that barangay officials observed these procedures correctly.

Table 8
Ranking on Parent Perception of Commonly Committed Offenses

Offenses	Responses	%
Violation of Curfew	27	35.5
Bullying	25	32.9
Robbery	20	26.3
Vandalism	17	22.4
Extortion	15	19.7
Shoplifting	14	18.4
Threat	14	18.4
Physical injury	13	17.1
Destruction of Property	13	17.1
Street Drinking	11	14.5

Table 8 presents the ranking on the perception of commonly committed offenses. Respondents viewed Curfew violation as the most committed offense with 27 or 25.5%; Bullying at 25 or 32.9%; Robbery 20 or 26.3%; Vandalism with 17 or 22.4%; Extortion with 5 or 19.7%; Shoplifting with 14 or 18.4%; Assault 14 with 18.4%; Physical Injury 13 with 17.1%; Destruction of Property 13 or 17.1%; Street Drinking with 11 or 14.5% respectively.

Table 9

Question: What do you think is the most appropriate penalty that be imposed on the following offenses:

Choice 1 Inform the parents of the violation

Choice 2 Lockup the offender in the Barangay Hall

Choice 3 Turnover to DSWD or the Police Station

Choice 4 Render Community Service

Offenses	Responses									
	1	%	2	%	3	%	4	%	Total	%
1. Physical Injury	37	48.7	11	14.5	20	26.3	8	10.5	76	100
2. Vandalism	28	36.8	17	17	8	10.5	23	30.3	76	100
3. Robbery	15	19.7	17	22.4	38	50	6	7.9	76	100
4. Bullying	46	60.5	8	10.5	12	15.8	10	13.2	76	100
5. Shoplifting	17	22.4	20	26.3	30	39.5	9	11.8	76	100
6. Street Drinking	39	51.3	19	25	12	15.8	6	7.9	76	100
7. Extortion	31	40.8	17	22.4	20	26.3	7	9.2	76	100
8. Threat	28	36.8	18	23.7	19	25	11	14.5	76	100
9. Destruction of Property	37	48.7	16	21.1	13	17.1	10	13.2	76	100
10. Violation of Curfew	26	34.2	29	38.2	6	7.9	15	19.7	76	100

Table 9 presents parent respondents' perception of an appropriate penalty on listed offenses. Parent respondents prefer summoning parents of children violating these offenses Physical Injury, Vandalism, Bullying, Street Drinking, Threat, Destruction of property, Violation

of curfew than an imposition of punitive penalties. At the same time, Shoplifting and Robbery are to be hand over to the DSWD or Police station; these two offenses drastically differ in the parent respondent's opinion than from all of the listed offenses.

Table 10
Parents Perception on Lowering Criminal Accountability
and Imprisonment of Negligent Parents

Questions	Yes	%	No	%	Total	%
1. Are you in favor of reducing the age of criminal accountability from 15 years old to 12 years old?	32	42.1	44	57.9	76	100
2. Are you in favor of imprisonment for a negligent parent of children that have violated ordinances?	35	46.1	41	53.9	76	100

Table 10 presents parent perception of lowering criminal accountability and imprisonment for negligent parents of child offenders.

Question 1 shows that 44 or 57.9% of the respondents are against the lowering of criminal accountability, while 32 or 42.1% are in favor. Question 2 yielded 41 or 53.9% of the respondents are against the imprisonment of negligent parents of child offenders, while 35 or 46.1% are in favor.

CONCLUSIONS

Derived from the study are the following:

1. The majority of the parent respondents confirm that barangay officials observe the procedures provided for by RA 9262 to investigate children who violated ordinances.
2. Parent respondents viewed that Violation of Curfew, Bullying, and Robbery are the three most committed offenses of child violators of the ordinance.
3. The majority of the parent respondents prefer summoning the parents of children offender in the following infractions, Physical Injury, Vandalism, Bullying, Street Drinking, Threat, Destruction of property, Violation of curfew. In contrast, they prefer a referral to DSWD or Police Station for those who committed Robbery and Shoplifting.
4. The majority of the parent respondents are against lowering the age of criminal accountability and imprisoning negligent parents of the child offenders of ordinances.

RECOMMENDATIONS

Based on the result of the study, it is recommended that:

1. The school and other concerned agencies must provide a support mechanism for the community to better understand the rights of children and women in an investigation, especially at the barangay level. The barangay is the first reflection of governance that officials must be aware of the approach and remedial measures to employ when handling child offenders of ordinances and the proper information and guidance of parents.

2. Parents should be aware of the limitation and conduct of the children and constantly remind them of the ill effect of misplaced trust on anyone. Sanguniang Kabataan should be educated on aspects of handling cases of child violator of ordinances and understand their role as their advocate, and promote progressive activities that will benefit their sectors, and abandon the traditional projects, activities, and programs that deal with sport, beauty contest, and other usual "youth-oriented" engagements.

3. Students of public administration and social work must conduct a deeper study on the effect of these procedures and the implication of administrative functions, including identification of financial and material support, personnel allocation, and psychological training to health and other barangay officials.

4. Local governments should reassess the functions of their respective barangay bureaus and extensively relocate some outdated operations to fieldwork. Engagement in proactive programs that promote positive cultural, spiritual, and educational growth of the youth and engage their productive capabilities will provide income and other means of livelihood that discourage them from committing offenses that will tarnish their future.

REFERENCES

Republic Act 9262 Violence Against Women and Their Children Act

Republic Act 7160 Local Government Code of the Philippines

Robert Flores, May 2003, Child Delinquency: Early Intervention and Detection, US Department of Justice

Maria Glenda Ramirez, Research on the Situation of Children in Conflict with the Law in Selected Metro Manila Cities, Save the Children UK Philippines Programme 2004

Republic Act 8369 An Act Establishing a Family Court

Craig Anderson, The Influence of Media Violence on Youth, Psychological Science in the Public Interest 2003, www.mtholyoke.edu/courses/jbickfor/anderson.et.al.2003.pdf

Guevara, R.M., & Bautista, F. S. (2008). Juvenile delinquency and crime prevention. Quezon City: Wiseman's Books Trading, Inc.

Republic Act. No. 9344. (2006) Juvenile Justice and Welfare Act of 2006

Villanueva, M.R. (2006). Juvenile delinquency. Manila: Philippine College of Criminology

<http://criminal-justice.iresearchnet.com/crime/juvenile-delinquency>

THE BENEFITS AND RISKS OF MOBILE PALENGKE IN PASIG CITY AND ITS SUSTAINABILITY

Evan John S. Magno

INTRODUCTION

Pasig City was known primarily as an industrial center, but in recent years, it has developed into a thriving residential commercial community with countless business centers, prominent schools, renowned restaurants, and lifestyle developments. Pasig is also known for its wide-ranging cosmopolitan lifestyle. Pasig is politically subdivided into 30 barangays. For the city council representation purposes, Pasig City grouped its barangays to two districts. The mayor of Pasig City is Mayor Vico Sotto.

Pasig Mega Market is located at Caruncho Avenue. Possibly the largest in the country, this public market spans three stories and 19,475 square meters of floor area. Approximately there are two thousand four hundred and forty-seven fixed stalls, plus some two thousand nine hundred sixty-seven stalls utilized as tiangge (flea market) on weekends. The public market has a four-story parking building, complete with a terminal for tricycles on the ground floor, perfect for the throngs of shoppers, even from adjacent cities. This place is crowded because there is a lot of business happening in here. The Pasig Mega Market sells different kinds of goods, materials, home equipment, basic necessities and many more. But now, people aren't allowed to be close to each other that's why some businesses got closed and some are declining.

Last January 30, 2020, the Philippine Department of Health reported the first case of COVID-19 in the country with a 38-year-old female Chinese national. The first local transmission of COVID-19 was confirmed on March 7. Thursday, September 3, 2020 had a total of 228K + 2,176 new cases, 159K recovered and 3,688+26 deaths. As we all know, seniors and people that are 21 years old and below aren't allowed to go out, adults are allowed only if needed, we can't be near people, we have to practice social distancing, we need to bring our alcohol, face mask and face shield with us always when we go out, and this is what we called the "new normal".

March 24, 2020, Vico Sotto, the Mayor of Pasig City, announced the launching of the "Mobile Palengke", a truck that serves as a store selling goods from the market. The Mobile Palengke was introduced by Mayor Vico Sotto to reduce the number of people going to the Pasig Mega Market and other markets, to avoid the spread of the virus and of course, to keep the people of the City safe and secured. Netizens instantly responded with praises for the popular Mayor of Pasig who was quick to correct impressions that he pioneered it, humbly tweeting that other local governments have done the same before him.

According to the news, there are five roving Mobile Palengke trucks around Pasig City and the schedules are posted on the Pasig City Public Information Office Facebook page. The roving store was placed into these barangays: Barangay Pinagbuhatan; Barangay Pineda; Barangay Ilog; Kapitolyo; and in San Miguel. It will go around areas across Pasig from 8:00 a.m. until all products are sold. One of the challenges that the consumer encounters is the risks in interacting with people and going out of their homes to buy their necessities. The consumers also worry if the people of the city were all given goods by the barangays.

With this concept the researchers are conducting this research to know more about the sustainability of Mobile Palengke and if there is a significant difference on the benefits and risks of Mobile Palengke assessed by barangay officials, residents and vendors.

MATERIALS AND METHODS

a. The participants of the research are two hundred fifty (250) barangay residents, one hundred fifty (150) barangay officials, and one hundred (100) vendors.

b. Administered and retrieved survey questionnaire from the respondents through Google survey form using random sampling during Second Semester School year 2020-2021. Collected, treated, analyzed, interpreted, and presented the data to answer to the sub problem of the study. The data were treated and analyzed using statistical tools such as: percentage, weighted mean, and ANOVA test.

RESULTS AND DISCUSSION

1. Products offerings of Mobile Palengke

Table 1
Product Offerings of Mobile Palengke

Products	Barangay Officials		Vendors		Residents		Total		Rank
	WM	VI	WM	VI	WM	VI	WM	VI	
Vegetable and fruits	2.87	OF	3.00	OF	3.56	AV	3.14	OA	1
Meat and Poultry	2.47	SA	2.60	OF	3.32	AV	2.80	OA	5
Seafood and fishes	2.87	OF	2.90	OF	3.12	OF	2.96	OA	4
Frozen products	2.73	OF	3.10	OF	3.12	OF	2.98	OA	3
Medical Supplies	3.20	OF	3.00	OF	3.16	OF	3.12	OA	2
Overall Weighted Mean	2.83	OF	2.92	OF	3.26	AV	3.00	OA	

Legend:

Scale	Range	Verbal Interpretation	Symbol
4	3.25 - 4.00	Always Available	AV
3	2.50 – 3.24	Often Available	OF
2	1.75 – 2.49	Sometimes Available	SA
1	1.01 – 1.74	Not Available	NA

All products offering rated as Often Available with overall weighted mean of 3.00. The following products offering are as follows: vegetable and fruits with weighted mean of 3.14 as rank 1; medical supplies with weighted mean of 3.12 as rank 2; frozen products with weighted mean of 2.98 as rank 3; sea foods and fishes with weighted mean of 2.96 as rank 4; and meat and poultry with weighted mean of 2.80 as rank 5.

2. Assessment of Mobile Palengke

2.1 Benefits

As reflected in Table 2, the mobile palengke's benefits rated as Highly Benefited with overall weighted mean of 3.25. Two items rated as Highly Benefited, such as: The goods come closer to consumers, and don't need to travel far with weighted mean of 3.32 as rank 1; and Continuous benefits not only for consumers but also for the buyers and suppliers of local goods with overall weighted mean of 3.29 as rank 2. Three items rated as Benefited, these are: Scheduled palengke day, lessens the risk of residents in crowded areas with weighted mean of

3.22 as rank 3; Prices of goods are also sold at a similar price with weighted mean of 3.13 as rank 4; and Cleanliness of the truck and containers of goods with weighted mean of 3.10 as rank 5.

Table 2
Mobile Palengke as to Benefits

Indicator	Barangay Officials		Vendors		Residents		Total		Rank
	WM	VI	WM	VI	WM	VI	WM	VI	
The goods come closer to consumers, and don't need to travel far.	3.20	B	3.20	B	3.56	HB	3.32	HB	1
Scheduled palengke day, lessens the risk of residents in crowded areas.	3.13	B	3.00	B	3.52	HB	3.22	B	3
Prices of goods are also sold at a similar price.	3.27	B	2.80	B	3.32	HB	3.13	B	4
Cleanliness of the truck and containers of goods.	3.00	B	3.10	B	3.20	HB	3.10	B	5
Continuous benefits not only for consumers but also for the buyers and suppliers of local goods.	3.20	B	3.20	B	3.48	HB	3.29	HB	2
Overall Weighted Mean	3.16	HB	3.06	HB	3.42	HB	3.25	HB	

Legend:

Scale	Range	Verbal Interpretation	Symbol
4	3.25 - 4.00	Highly Benefited	HB
3	2.50 – 3.24	Benefited	B
2	1.75 – 2.49	Slightly Benefited	B
1	1.01 – 1.74	Not Benefited	NB

2.2 Risks

Table 3
Mobile Palengke as to Risks

Indicator	Barangay Officials		Vendors		Residents		Total		Rank
	WM	VI	WM	VI	WM	VI	WM	VI	
Inconsistency in the observance of safety protocol.	2.53	OR	2.40	SR	2.84	OR	2.59	OR	1
Irregular security precautions.	2.20	SR	2.60	OR	2.76	OR	2.52	OR	2
Uncontrolled practice of one meter distance of the consumers.	2.13	SR	2.20	SR	2.80	OR	2.38	SR	4
No requirements of contact tracing.	2.20	SR	2.20	SR	2.80	OR	2.40	SR	3
Exposed with pollution of the products.	2.27	SR	2.10	SR	2.72	OR	2.36	SR	5
Overall Weighted Mean	2.27	SR	2.30	SR	2.78	OR	2.45	SR	

Legend:

Scale	Range	Verbal Interpretation	Symbol
4	3.25 - 4.00	Highly Risky	HR
3	2.50 – 3.24	Often Risky	OR
2	1.75 – 2.49	Slightly Risky	SR
1	1.01 – 1.74	Not Risky	NR

As revealed in Table 3, the mobile palengke's risks are rated as Slightly Risky with overall weighted mean of 2.45. Two items rated as Slightly Risky, namely: Inconsistency in the observance of safety protocol with weighted mean of 2.59 as rank 1; and Irregular security precautions with weighted mean of 2.52 as rank 2. Three items rated as Slightly Risky, these are: No requirements of contact tracing with weighted mean of 2.40 as rank 3; Uncontrolled practice of one-meter distance of the consumers with weighted mean of 2.38 as rank 4; and Exposed with pollution of the products with weighted mean of 2.36 as rank 5.

3. Comparative Assessment Among of Barangay officials, Residents, and Vendors?

Table 4
Comparative Assessment of Mobile Palengke's Benefits and Risks

Areas of Concern		SS	MS	Df	F-value	Critical Value	Interpretation	Decision
1. Benefits	Bet. Grp.	0.067	0.033	2	10.2336	6.93	Significant	Reject Ho
	Within Grp.	0.039	0.003	12				
2. Risks	Bet. Grp.	0.167	0.083	2	3.79834	6.93	Not Significant	Accept Ho
	Within Grp.	0.008	0.022	12				

Level of Significance: 0.05

As manifested in Table 4, the computed F-value of benefits is 10.2336 which are higher than the critical value of 6.93 with 2 and 12 degree of freedom. Hence, there is significant difference in Mobile Palengke's Benefits as assessed by barangay officials, vendors and residents. Therefore, the hypothesis is rejected. On the other hand, the computed F-value for risks is 3.79834 which is lower than the critical value of 6.93 with 2 and 12 degree of freedom. Hence, there is no significant difference on the Mobile Palengke's Risks as assessed by barangay officials, vendors and residents. Therefore, the hypothesis is accepted.

CONCLUSION

In view of the foregoing findings, the following conclusions are made:

1. Among the Mobile Palengke offerings; Vegetables and fruits, Seafood and fishes, frozen products are sometimes available except Meat and poultry is not available.
2. Assessment of barangay officials, vendors and residents to Mobile Palengke as to benefits is highly beneficial and slightly risky in Risks.
3. Comparative assessment of Mobile Palengke as to benefits is significant and rejected, as to risk not significant and accepted.

RECOMMENDATIONS

Based on the findings and conclusion the following recommendations are drawn:

1. As to Meat and Poultry availability, Mobile Palengke needs to allot more stock in serving a variety of meat and poultry to the consumers. They can also add more roving carts or vendors that can sell meat and poultry into different barangays. Being aware of local regulatory policies related to providing essential services and group gatherings to determine if

Mobile Palengke can be held, and if there are restrictions limiting the number of residents and vendors to also avoid shortage.

2. As to Benefits, Mobile Palengke has to stock a variety of products offered, especially with meat and poultry as shown on the tables before that meat and poultry is not available. Consider asking vendors to pre-bag or pre-portion items for sale prior to market. To implement cashless payment systems when exchanging paper and coin money

3. As to Risks, Mobile Palengke maintains to limit market activities that target individuals identified as higher risk for serious illness for COVID-19, if feasible. If these events or activities continue to be offered, consider creating a schedule that includes special shopping hours for at-risk. Consider regular symptom screenings of staff, vendors or others that come onsite, and have a plan for if anyone arrives or becomes ill. The Mobile Palengke have trained staff, vendors and volunteers to observe and perform the new procedures on Covid-19. Conceivably, conducting training virtually therefore every single person can attend and gathering multitude of people will be avoided. Require staff, volunteers, and vendors to wash their hands for at least 20 seconds with soap and water (or use hand sanitizer) frequently before, during, and after shifts. Staggering eating/break times and identifies a designated area for staff and volunteers to take breaks where social distance can be maintained for vulnerable populations.

4. As to sustainability of the Mobile Palengke, the researchers suggest that the barangay officials must establish a protocol wherein they will conduct a free antigen/rapid test to both the vendors and consumers. They also need to make sure that the products and the Mobile Palengke itself are thoroughly cleaned on a daily basis, frequently. The researchers would also like to recommend that they should maximize the variety of stocks available for the residents and additional mobiles/trucks that will rove around different areas in Pasig City. The barangay officials may also take note of surveys for the residents about the Mobile Palengke, so that they would know what needs to be improved or needs to be changed immediately. Consistent quality of service by organizing better options in purchasing during operating hours and only fresh products should be endorsed, producing reliable information about the current set up through alert messages via SMS and personal emails, and assurance of security measures to the residents, vendors, officials, and to the whole community must be the top priority.

REFERENCES

A. Journal / Periodicals

Aireen L., "Foodcart, still a hot business", Foodcartlink, September 10, 2016.

Borham Y. "Consumer Attitude and Visit Intention toward Food Trucks: Targeting Millennials", Food Service Business, November 27, 2017.

Brett L., "How to Start a Food Truck in the Philippines", Food Truck Empire, January 31, 2016.

Dan S., "The Global Resurgence of Street Food", Euromonitor International, July 11, 2016

Guzman, Jimmyley E. "Pasig LGU rolls out 'Mobile Palengke to bring basic goods closer to people" Philippine Information Agency. March 25, 2020.

JC Gotinga., "Pasig launches 'Mobile Palengke to lessen Markets trips" Rappler, March 24, 2020

- Leone, L.A., Tripicchio, G.L., Haynes-Maslow, L. et al., "Cluster randomized controlled trial of a mobile market intervention to increase fruit and vegetable intake among adults in lower-income communities in North Carolina" *International Journal of Behavioral Nutrition and Physical Activity*. January 5, 2018
- Luz, Juan Miguel, "[ANALYSIS] Too many children not enrolled this school year is a major concern" *Rappler*, November 19, 2020.
- Madarang, Catalina Ricci S. "Pasig City's 'Mobile Palengke' initiative lifted from social media idea" *Philstar*, March 24, 2020.
- Medenilla, Vina. "DA will be selling vegetables and other commodities via Jeepney." *Manila Bulletin Publishing, Inc.* March 30, 2020.
- Neil M., "Use more mobile palengke in communities LGUs told" *INQUIRER*. April 14, 2020.
- Rita M., "Grocery Shopping at Community Markets During the COVID-19 Pandemic" *OhMyHome*, May 9, 2020.
- Yershov Danila, "CM rolls out farmers' market on wheels". *The Hindu by Mumbai*. August 16, 2017.

B. Thesis / Dissertation (Follow the format, surname, initial and year of publication.

- Alamo-Tonelada, C. Silaran, F. Bildan, M.A. (2018) "Sanitary Conditions of Food Vending Sites and Food Handling Practices of Street Food Vendors: Implication for Food Hygiene and Safety" Department of Hotel and Restaurant Management College of Business and Accountancy, *Tarlac State University*. *Tarlac, Philippines*.
- De Asis, R. Aniñon, J.C. Bayron, A. Cambare, Z. Jr. Dagupan, R. Echeveria, J.A. Gamalo D.J. Ontong, E.Z. (2017). *Multi-featured Food Cart .BS Electrical Technology and Management, University of Science and Technology of Southern Philippines/College of Technology, and Lapanan, Cagayan de Oro City*.
- Platon, C. Pambid, R. Lomboy, E. (2017). "Food Safety among Native Delicacy Producers and Vendors in the Public Market of Bayambang in Pangasinan, Philippines" *Pangasinan State University, Philippine*. *Philippines*.

C. Online Sources

- Business Wire (2020) *Philippines Mobile Market During the Period, 2020-2024*. Retrieved from: <https://www.businesswire.com/news/home/20200302005490/en/Philippines-Mobile-Market-During-the-Period-2020-2024---ResearchAndMarkets.com>. Retrieval date: March 2, 2020.
- FranchiseManila.com (2018) *FOOD CARTS: The Ultimate Small Business to Start in the Philippines*. Retrieved from: <https://franchisemanila.com/2018/10/food-carts-the-ultimate-small-business-to-start-in-the-philippines/> Retrieval date: September 3, 2020.
- Gary W., et al. (2018) "Evaluation of a Mobile Farmer's Market Aimed at Increasing Fruit and Vegetable Consumption in Food Deserts: A Pilot Study to Determine Evaluation Feasibility" Retrieved from: <https://www.liebertpub.com/doi/10.1089/heq.2018.0003> Retrieval date: December 18, 2018

- Hsiao B. (2016) "Mobile Produce Markets: A Strategy for Increasing Access to Mobile Produce Markets: A Strategy for Increasing Access to Fruits and Vegetables Among Low Income Urban Residents Fruits and Vegetables Among Low Income Urban Residents" Retrieved from: https://scholarworks.umass.edu/masters_theses_2/423/ Retrieval date: November 2016
- Ibis World (2020) Food Trucks Industry in the US - Market Research Report. Retrieved from: <https://www.ibisworld.com/united-states/market-research-reports/food-trucks-industry/>. Retrieval date: September 23, 2020.
- J & B Associates (2019) The Food Truck Theory. Retrieved from: <https://jbcassociates.net/food-truck-theory/>. Retrieval date: 2019.
- Ligia A., et al. (2019) Brazilian Food Truck Consumers' Profile, Choices, Preferences, and Food Safety Importance Perception, Retrieved from: <https://www.ncbi.nlm.nih.gov/pmc/articles/PMC6566650/> Retrieval date: May 25, 2019.
- KBK, GMA News (2020) New barangay schedule implemented in Pasig Mega Market. Retrieved from: <https://www.gmanetwork.com/news/news/metro/752756/new-barangay-schedule-implemented-in-pasig-mega-market/story/>. Retrieval date: August 25, 2020.
- Likha (2020) CARD MRI continues services despite COVID-19 Retrieved from: <https://www.cardmri.com/mlni/?p=501> Retrieval date: April 12, 2020.
- Manila Bulletin (2020) The New Normal: 9 Initiatives We Can Continue Even After COVID - 19 Pandemic Is Lifted. Retrieved from: <https://mb.com.ph/2020/04/19/the-new-normal-9-initiatives-we-can-continue-even-after-covid-19-pandemic-is-lifted/>.
- Mindanao Goldstar Daily (2020) Kauswagan Norte rolls out 'organic mobile palengke'. Retrieved from: <https://mindanaogoldstardaily.com/kauswagan-norte-rolls-out-organic-mobile-palengke/>. Retrieval date: October 7, 2020
- Philippine Statistics Authority (2020) City of Pasig: Population Reached Half a Million Retrieved from: <https://psa.gov.ph/content/city-pasig-population-reached-half-million> Retrieval date: October 10, 2022
- SBDC Net (2020) Food Truck Business. Retrieved from: <https://www.sbdcnet.org/small-business-research-reports/food-truck-business>. Retrieval date: June 12, 2020
- Wageningen University & research. "Veg-on-wheels: ready-to-cook vegetables for Nigerian consumers." Retrieved from: <https://www.wur.nl/en/newsarticle/Veg-on-wheels-ready-to-cook-vegetables-for-Nigerian-consumers.htm> Retrieved Date: December 14, 2018.
- Velázquez Onésimo Cuamea, Ramos Higuera Karen G. (2017). "Food trucks, small bricks and mortar restaurants: gastronomic collective. Key factors for an emerging customer profile." Retrieved from: <https://www.amiturismo.org/socios/onesimocuamea/> Retrieval date: September 20, 2017
- Holmes Mark R.1, Dodds Rachel2, Deen George2, Lubana Anna2, Munson Jessica2, Quigley Sarah2. (2018). Local and Organic Food on Wheels: Exploring the Use of Local and Organic Food in the Food Truck Industry. Retrieved from: <https://onlinelibrary.wiley.com/doi/abs/10.1002/9781119373780.ch21>

ENTREPRENEURIAL PRACTICES AMONG WOMEN IN BARANGAY 634 BASIS FOR SCHOOL AND COMMUNITY ENTREPRENEURIAL PARTNERSHIP PROGRAM

Dr. Anna Victoria V. Mailas

INTRODUCTION

Entrepreneurship runs a big impact in the world, anywhere we go, entrepreneurship is involved, from the moment they buy their needs to the moment they wanted to start a business. According to Merriam Webster Dictionary, Entrepreneur is a person who starts a business and willing to loss in order to make money. It could also mean that person who organized and manages a business or an enterprise.

STATEMENT OF THE PROBLEM

The study aims to determine the entrepreneurial practices specifically, among women in Barangay 634 it seeks to answer the following:

1. What is the demographic profile of the respondents as to:
 - 1.1 Age;
 - 1.2 Civil Status;
 - 1.3 Number of Independent;
 - 1.4 Educational Attainment;
 - 1.5 Business Type; and
 - 1.6 Forms of ownership?
2. What are the entrepreneurial motivation as to:
 - 2.1 Financial;
 - 2.2 Personal;
 - 2.3 Social; and
 - 2.4 Psychological?
3. What are the entrepreneurial practices among women in terms of:
 - 3.1 Health and Sanitation;
 - 3.2 Marketing/Selling;
 - 3.3 Lending;
 - 3.4 Merchandising; and
 - 3.5 Financial Statement Preparation?
4. Is there a significant relationship between the entrepreneurial motivation and demographic profile of the respondents?
5. Based on the results of the study, what school and community entrepreneurial partnership may be prepared?

Research Design

The author used the descriptive method type of research in gathering the data. It is used to describe characteristics of a population or phenomenon being studied. It does not answer questions about how/when/why the characteristics occurred; rather it addresses the "what" question. Descriptive method describes what is it involves the description, recording, analysis, and interpretation. The focus in the prevailing conditions, or how a person, group or thing behaves and observation Under the descriptive research method the author used survey method, conducted an interview to female entrepreneurs to further understand the problem.

Population Sampling

The author used the purposive sampling method also known as judgement, selective or subjective sampling as her sampling technique. Purposive sampling is intentional selection of information based on their ability to clarify a specific theme, concept, or phenomenon. The selection process involves identifying themes, concepts and indicators through observations and reflections. The author chooses her participants according to their needs of the study.

Research Instrument

The research instrument used by the author is survey questionnaires which the author prepared for the purpose to gather the needed data for the study.

In this research the questionnaires were consist of 3 parts.

Part I. Demographic profile of the respondents in terms of age, gender, civil status and attainment.

Part II. Entrepreneurial Motivation among Women

Part III. The Entrepreneurial Practices Among Women

Statistical Treatment of Data

1. The following statistical tools and techniques were used to ensure valid and systematic presentation, analysis and interpretation of data.

2. Frequency Count and Percentage. These two descriptive measures were used in presenting the profile of the respondents.

3. Weighted Mean. This method was used in determining the typical assessment of the respondents with regards to the following variables: financial, personal social and psychological, production, marketing/selling, lending and services in entrepreneurial motivation and practices.

4. Pearson Correlation. This method was used to determine whether or not significant relationship between the assessment of the two groups of respondents on entrepreneurial motivation and entrepreneurial practices in Barangay 634 will be solved with this formula.

SUMMARY OF FINDINGS

Entrepreneurial Motivation of the Respondents

1. In terms of Financial Motivation, the respondents are highly motivated in terms of earning their own wealth thru business and surviving in everyday life.
2. In terms of Personal Motivation, the respondents are motivated in having independence in having their own decision is a benefit for them to have their own business.
3. In terms of Social Motivation, the respondents are highly motivated proving that women can also be an entrepreneur.
4. In terms of Psychological Motivation, the respondents are highly motivated in able to earn a reasonable living.

CONCLUSION

As to Entrepreneurial Motivation of the respondents, they are highly motivated in improving their Financial, Personal, Social and Psychological.

RECOMMENDATION

The researchers recommended creating opportunities for women and addressing the socio-cultural constraint in the society, conduct financial conference and webinars b, and showing them the advantage and dising advantage of being an entrepreneur versus employee

ENTREPRENEURIAL PRACTICES OF THE RESPONDENTS

1. As to health and sanitation, placing food in proper storage and temperature to avoid spoilage is highly practiced.
2. As marketing/ selling focusing on the target market to improve the strategies, applying suitable pricing and providing good quality and service are highly practiced.
3. As to lending, borrowing money from family and friends and offering collateral as a form of security are moderately practiced.
4. As to merchandising, maximizing customer interest and sales in maintaining store shelves inventory are highly practiced.
5. As to financial statement preparation, developing and managing action plans in finding financial report are moderately practiced.

CONCLUSION

As to Entrepreneurial Practices, improving Health and Sanitation, Marketing and Selling and Merchandising are highly practiced while lending and Financial Statement Preparation are moderately practiced.

RECOMMENDATION

The researchers recommended using social media as a promotional tool to make products known to the market, conduct webinars about lending and preparing financial statement preparation and ways to improve in the merchandising aspect.

Significant relationship between the entrepreneurial practices to entrepreneurial motivation and demographic profile of the respondents.

The comparative relationship between the entrepreneurial practices and entrepreneurial motivation of women as to personal and social have strong and perfect correlation. Therefore, the hypothesis is rejected. While the entrepreneurial practices and entrepreneurial motivation of women as to financial and psychological in terms of health and sanitation and merchandising have weak correlation, therefore the hypothesis are accepted but, on the marketing/selling, lending and financial statement preparation it has strong correlation, therefore the hypothesis are rejected .

TEACHERS' PHILOSOPHICAL PERSPECTIVES AND THEIR CURRICULUM ENGAGEMENT: TOWARDS ARTICULATING A PHILOSOPHY OF TEACHING

Dr. Eric C. Mendoza

INTRODUCTION

Teachers bring myriad attitudes, beliefs, and dispositions which impact the totality of their teaching experience. Throughout their teacher preparation and in the actual practice of their profession, teachers have been impacted by different curricula such as the explicit curriculum, implicit curriculum, and null curriculum. Interestingly, practically everything we do in education reflects the outcomes of the planned and unplanned experiences with which we have engaged. Teachers must develop and articulate their philosophy of teaching. This will empower and capacitate them since it is implicit in their work as teachers (Ebert II, E.S. & Culyer II, R.C., 2011). Such a philosophy of teaching encompasses personal beliefs about teaching and learning, disciplinary cultures, institutional structures and cultures, and stakeholder expectations. (Schonwetter, D.J., Sokal, L., Friesen, M. & Taylor, K. L, 2002).

Their philosophy of education is at the heart of their profession as they gain understanding through critical reflection and speculation about the 'big' abstract questions of the role of education to seemingly trivial questions in classroom management (Orchard, J., Heilbronn, R. & Winstanley, C., 2016). In any of these situations, teachers are challenged to articulate their teaching philosophy. In so doing, they grow personally and professionally as they continually reflect and consider their individual goals, actions, and vision in carrying out their teaching mission.

Throughout their teacher preparation and the actual practice of their profession, teachers have been impacted by different curricula. Interestingly, practically everything we do in education reflects the engagement that teachers have with the explicit curriculum or the actual subjects taught and the announced character traits that the school wishes to instill in its students, the implicit curriculum or the unspoken lessons and values that the district/school supports), and the null curriculum or the topics and issues that the state or local district/school has specifically chosen not to present to its students (Ebert II, E.S & Culyer II, R.C., 2011).

OBJECTIVES

This research paper examines the relevance of curriculum engagement to the philosophical perspectives of teachers. Specifically, the research focuses on (a) identifying the philosophical perspectives of the teacher-respondents, (b) determining the relevance of the curriculum engagement of the teacher-respondents, and (c) exploring the relationship between the teachers' philosophical perspectives and the three types of curriculum that teachers have engaged throughout their academic experience.

METHODOLOGY

The study utilized the descriptive-correlational survey method and the sample comprised of 80 public school teachers. Data were gathered using two sets of questionnaires that were adapted from self-assessment activities regarding philosophical perspectives and

types of curriculum (Ebert II, E.S. & Culyer III, R.C. (2012). Data analysis was undertaken using a chi-square test of independence at a 0.05 level of significance.

RESULTS AND DISCUSSION

Philosophical Perspectives of Teachers

Table 1
Philosophical Perspectives of Teachers

Philosophical Perspectives	Frequency	Percentage
Progressivism	26	32.50
Essentialism	20	25.00
Perennialism	7	8.75
Social Reconstructionism	9	11.25
Eclecticism	18	22.50
Total	80	100

The first objective of the study was to identify the philosophical perspectives of the teacher-respondents. Table 1 presents the distribution of the teacher-respondents according to their philosophical perspectives. It shows that Essentialism is advocated by a majority of the respondents while progressivism and social reconstruction have an equal number of advocates. There were a few believers in social reconstructionism and perennialism with the latter having the lowest number of advocates.

This implies that teachers have varied philosophical perspectives from which they seek understanding of the purpose and process of education, in general, and teaching, in particular. These different schools of philosophies enable the teacher to have a holistic view of the educational task and how it relates to other aspects and concerns of life, particularly, in the educational setting. These philosophical perspectives are guiding insights to clarify and criticize concepts and theories to yield progressively coherent schemes of interpretation.

Relevance of the Curriculum Engagement

The second objective of the study was to determine the relevance of the curriculum engagement of the teacher respondents according to their philosophical perspectives.

Table 2
Relevance of the Explicit Curriculum Engagement

Philosophical Perspectives	Explicit Curriculum			
	Very Relevant (4)	Relevant (3)	Least Relevant (2)	Not Relevant (1)
Progressivism	67 (83.75%)	10 (12.50%)	2 (2.50%)	1 (1.25%)
Essentialism	68 (85.00%)	8 (10.00%)	3 (3.75%)	1 (1.25%)
Perennialism	59 (73.75%)	19 (23.75%)	1 (1.25%)	1 (1.25%)
Social Reconstructionism	61 (76.25%)	16 (20.00%)	1 (1.25%)	2 (2.50%)
Eclecticism	53 (66.25%)	25 (31.25%)	1 (1.25%)	1 (1.25%)
Average	77.00%	19.50%	2%	1.5%

Table 2 presents the different assessments of the teacher-respondents on the relevance of the explicit curriculum engagement vis-à-vis their philosophical perspectives. The greater majority of the teacher-respondents (77.00%) expressed that the Explicit Curriculum is very relevant to their philosophical perspectives. However, 19.50% of respondents considered the explicit curriculum as relevant, 2% of respondents claimed it is least relevant, and 1.5% of respondents expressed not relevant. This recognizes the emphasis on the prescribed curricular contents that are specified in curriculum guides and syllabus which mandates the subject matter of the discipline. Currently, this is best exemplified by the Most Essential Learning Competencies (MELC) issued by the Department of Education that teachers are required to teach as the educational system adapts to the demands of the new normal due to the COVID-19 pandemic.

Table 3
Relevance of the Implicit Curriculum Engagement

Philosophical Perspectives	Explicit Curriculum			
	Very Relevant (4)	Relevant (3)	Least Relevant (2)	Not Relevant (1)
Progressivism	49 (61.25%)	20 (25.00%)	8 (10.00%)	3 (3.75%)
Essentialism	46 (57.50%)	23 (28.75%)	9 (11.25%)	2 (2.50%)
Perennialism	49 (61.25%)	18 (22.50%)	10 (12.50%)	3 (3.75%)
Social Reconstructionism	58 (72.50%)	10 (12.50%)	9 (11.25%)	3 (3.75%)
Eclecticism	49 (61.25%)	22 (27.50%)	8 (10.00%)	1 (1.25%)
Average	62.75%	23.25%	11.00%	3.00%

Table 3 presents the different assessments of the teacher-respondents on the relevance of the implicit curriculum engagement vis-à-vis their philosophical perspectives. The greater majority of the teacher-respondents (67.75%) expressed that Implicit Curriculum is very relevant to their philosophical perspectives. There are 23.25% of respondents who considered the implicit curriculum is relevant. There are 11% of respondents who manifested that the implicit curriculum is least relevant. However, 3% of respondents said the curriculum engagement is not relevant.

As reflected in Table 4, the different assessments of the teacher-respondents on the relevance of the null curriculum engagement vis-à-vis their philosophical perspectives are very relevant (32.50%), relevant (23.75%), least relevant (17.50%), and not relevant (26.25%). These varied assessments reflect that a null curriculum has vital significance and an educational function even though several respondents (26.25%) consider it not relevant to one's philosophical perspective.

Table 4
Relevance of the Null Curriculum Engagement

Philosophical Perspectives	Explicit Curriculum			
	Very Relevant (4)	Relevant (3)	Least Relevant (2)	Not Relevant (1)
Progressivism	33 (41.25%)	18 (22.50%)	16 (20.00%)	13 (16.25%)
Essentialism	12 (15.00%)	15 (18.75%)	16 (20.00%)	37 (46.25%)
Perennialism	5 (6.25%)	5 (6.25%)	26 (32.50%)	44 (55.00%)
Social Reconstructionism	29 (36.25%)	31 (38.75%)	10 (12.50%)	10 (12.50%)
Eclecticism	51 (63.75%)	26 (32.50%)	2 (2.50%)	1 (1.25%)
Average	32.50%	23.75%	17.50%	26.25%

These results highlight how this diversity in assessments concurs with the widely accepted impression that people have different philosophical positions on knowledge, activities, values, and experiences that are carried through the curriculum. Also, this recognizes the engagement of the teachers in the various curricula that are available in the formal setting such as the school. The aims and purposes of education, curriculum content, teaching methods, and many other areas of educational endeavor are essential considerations that define every facet of the teachers' professional and personal life.

Relationship between Philosophical Perspectives and Curriculum Engagement

To test the relationship between the teachers' philosophical perspectives and their engagement with various types of curricula, the chi-square test of independence was undertaken and the results are as follows:

Table 5
Relationship between Philosophical Perspectives and Curriculum Engagement

Variables	Chi-square statistic	p-value	Decision
Philosophical Perspective and Explicit Curriculum	17.2492	p-value = .140453	The result is not significant at $p < .05$.
Philosophical Perspective and Implicit Curriculum	9.0644	p-value = .697424	The result is not significant at $p < .05$.
Philosophical Perspective and Null Curriculum	159.6615	p-value < 0.00001	The result is significant at $p < .05$

These results indicated that there is no relationship between philosophical perspectives and engagement in both explicit, $X^2(12, N = 80) = 17.2492, p = .140453$ and implicit curriculum, $X^2(12, N = 80) = 9.0644, p = .697424$ but there is a relationship between philosophical perspective and the null curriculum, $X^2(12, N = 80) = 159.6615, p < 0.00001$. This finding was unexpected and suggests a need to re-evaluate the curricular content since the null curriculum is often intentionally excluded from the awareness of learners in the school setting. However, it has an impact that has to be considered. Although it poses a challenge to discuss how these curriculum orientations influence the choices of teachers in the educational policy practices (Jenkins, 2009), this indicates a practical implication of the findings showing a greater need to explore other factors that influence the development and articulation of one's philosophy of teaching.

CONCLUSION AND RECOMMENDATIONS

The study established that philosophical perspectives and the curriculum engagement of teachers have mutual influence in developing and articulating a teacher's philosophy of teaching. Although only the null curriculum engagement indicated a direct influence in articulating the philosophical perspective, there is a need to look closely at the substantiality of the explicit curriculum particularly concerning breadth and depth of discussion and integration of the role of philosophy of education in teacher education programs (Winch, 2012) and the indirect influence of implicit curriculum to foster intelligent understanding of the educational

milieu in which the teacher functions. Further studies may be undertaken on various concerns such as curriculum models and pedagogical approaches (Di Masi, Diego & Santi, Marina, 2016; Kieser, 2016; Brownlee et al., 2014), the critical evaluation of assumptions about teaching and learning (Reber, 2011), the role of extra-curriculum or co-curriculum, and the wisdom of content exclusions in the curriculum as well as the influence of other contemporary social and technological factors in nurturing and articulating a personal philosophy of teaching.

REFERENCES

- Brownlee, J., Curtis, E., Chesters, S. D., Cobb-Moore, C., Spooner-Lane, R., Whiteford, C. & Tait, G. (2014). Pre-service teachers' epistemic perspectives about philosophy in the classroom: It is not a bunch of 'hippie stuff'. *Teachers and Teaching*, 20(2), 170-188. doi: 10.1080/13540602.2013.848565
- Di Masi, D. & Santi, M. (2016). Learning democratic thinking: A curriculum to philosophy for children as citizens. *Journal of Curriculum Studies*, 48(1), 136-150. doi: 10.1080/00220272.2015.1088064
- Ebert II, E.S. & Culyer III, R., C. (2012). *Introduction to Education*. Andover: Cengage Learning.
- Jenkins, S. B. (2009). Measure teacher beliefs about curriculum orientations using the modified-curriculum orientations inventory. *The Curriculum Journal*, 20(2), 103-120. doi: 10.1080/09585170902948798
- Kieser, D. L.(2016). Honing teaching philosophies: Creating Pedamantras. *Kappa Delta Pi Record*, 52(4), 188-189. doi: 10.1080/00228958.2016.1223998
- MELCs per Subject (SY 2020-2021). Retrieved from <https://www.deped-click.com/2020/05/melcs-per-subject-sy-2020-2021.html>
- Orchard, J., Heilbronn, R. & Winstanley, C. (2016). Philosophy for teachers (P4T)-developing new teachers' applied ethical decision-making. *Ethics and Education*, 11(1), 42-54. doi: 10.1080/17449642.2016.1145495
- Ozmon, H. & Craver, S. (1981). *Philosophical foundations of education* (2nd ed.). Columbus, Ohio: Bell & Howell Company
- Reber, J;. (2011). The under-examined life: A proposal for critically evaluating teachers' and students' philosophies of teaching. *College Teaching*, 59(3), 102-110. 10
- Schonwetter, D. J., Sokal, L., Friesen, M. & Taylor, K. L. (2002). Teaching philosophies reconsidered: A conceptual model for the development and evaluation of teaching philosophy statements. *International Journal for Academic Development*, 7(1), 83-97. doi: 10.1080/13601440210156501
- Winch, C. (2012). For philosophy of education in teacher education. *Oxford Review of Education*, 38(3), 305-322. doi: 10.1080/03054985.2012.693299

AWARENESS ON LOCAL POLICE HOTLINE NUMBER OF THE RESIDENTS OF SELECTED BARANGAY IN GEN. MARIANO ALVAREZ, CAVITE

Edzel G. Peña
Dr. Shirley P. De Leon

INTRODUCTION

Most developed countries have a number of emergency services operating within them whose purpose is to provide immediate assistance or intervention to lessen the worsening of the situation. There are different kinds of emergency services, such as medical, fire and police emergency services which accommodate base on incident happened. But in the Philippines, one of the most essential emergency services is from the police because of the constantly increasing number of crime in every place.

The Philippine National Police (PNP), together with other agencies, established the nationwide emergency/ hotline number, 911. The frequent first responder when you call is the police officers because they are the one who will assist or respond first to the incident that has been reported. On August 1, 2016, Former PNP Director General “Bato” Dela Rosa together with Secretary Martin Andanar and other agencies, announced in other television the effectiveness on nationwide emergency and police hotline number to prevent the commission of crime and to lessen the crime rate in our country.

Except from the nationwide hotline number, every police station has the police emergency/ hotline number which are provided in every community. But the problem is the awareness of residents regarding to their local police hotline number. That is why it is essential to study the awareness of the residents of the community regarding police emergency number and the factors affecting it. Also the Philippine National Police (PNP) needs the public to cooperate or help them in cases of emergencies to make their service more efficient and faster for the safety and security of everyone.

METHODS

This study will be made in accordance to the descriptive method of research. John Wiley and Son (2004), in his book of “ A Guide to Managing Research” said that the descriptive method of research can be explained as a statement of affairs as they are at present with the researcher having no control over variable. Moreover, descriptive studies maybe characterized as simply the attempt to determine, describe or identify what is, while analytical research attempts to establish why is it that way or how it came to be. In this study, the researcher will determine or identify the level of awareness of residents in selected barangays of General Mariano Alvarez, Cavite about police hotline number through the process of collecting and gathering data.

MATERIALS

In this study, survey questionnaire will be used to determine the awareness of the community about police hotline number. Questionnaire is easy to use and the respondents can give an accurate and specific answer to a certain questions based on their knowledge and keeping all answer confidential. The questionnaire contains the demographic profile of the

respondents according to their age, gender, highest educational attainment, occupation and years residing in barangay, level of awareness about hotline number answered by the numerical scale of 1 (Not at all aware) 2 (Slightly aware) 3 (Undecided) 4 (Moderately aware) and 5 (Fully aware) and the factors that affect their awareness to the police hotline number answered by the numerical scale of 1 (strongly Disagree) 2 (Disagree) 3 (Undecided) 4 (Agree) 5 (Strongly Agree). Also the researcher used the interview and internet to support the study conducted.

RESULT AND DISCUSSION

1. Demographic Profile of the Respondents as to:

1.1 Gender

Table 1
Profile of the Respondents as to their Gender

GENDER	FREQUENCY	PERCENTAGE
Male	79	39.5%
Female	121	60.5%
Total	200	100%

It can be seen from table 1 that male respondents has a frequency of 79 and covers 39.5% of the total number of respondents while female respondents has a frequency of 121 and covers 60.5% of the total respondents to sum it up, we have a total of 200 respondents or 100%.

1.2 Age

Table 2
Profile of the Respondents as to their Age

AGE	FREQUENCY	PERCENTAGE
18-25	35	17.5%
26-35	38	19%
36-45	38	19%
46-55	42	21%
56-Above	47	23.5%
Total	200	100%

It can be seen from table 2 that most of the respondents are coming from 56-above age group with a frequency of 47 or 23.5% of the total respondents. Following is the 26-35 and 36-45 age group with the frequency of 38 or 19% of the total respondents. To sum it up, there is a total of 200 respondents or 100%.

1.3 Highest Educational Attainment;

Table 3
Profile of the Respondents as to their Highest Educational Attainment

EDUCATIONAL ATTAINMENT	FREQUENCY	PERCENTAGE
College Graduate	25	12.5%
College Undergraduate	42	21%
Senior High School Graduate	0	0%
Senior High School Undergraduate	5	2.5%
High School Graduate	76	38%
High School Undergraduate	31	15.5%
Elementary Graduate	10	5%
Elementary Undergraduate	4	2%
Vocational	7	3.5%
Total	2000	100%

It can be seen from table 3, most of the respondents are high school graduate with a frequency of 76 or 38% of the total respondents. Next is college graduate with a frequency of 42 or 21% of the total respondents. Following is high school undergraduate with a frequency of 31 or 15.5% of the total respondents. Then college graduate with a frequency of 25 or 12.5% of the total respondents. Next is elementary graduate with a frequency of 10 or 5% of the total respondents. Following is vocational course with a frequency of 7 or 3.5% of the total respondents. Next is senior high school under graduate with a frequency of 5 or 2.5% of the total respondents. Then elementary undergraduate with a frequency of 4 or 2% of the total respondent. And the least is senior high school graduate with a frequency of 0 or 0% of the total respondents. To sum it up, there is a total of 200 respondents or 100%.

1.4 Occupation

Table 4
Profile of the Respondents as to their Occupation

OCCUPATION	FREQUENCY	PERCENTAGE
Employed	86	43%
Unemployed	114	57%
Total	200	100%

It can be seen from table 4 that most of the respondents are unemployed which is housewife and student with a frequency of 114 or 57% of the total respondents while some of the respondents are employed with a frequency of 86 or 43% of the total respondents. To sum it up, there is a total of 200 respondents or 100%.

1.5 Years Residing in Barangay

Table 5
Profile of the Respondents as to their number of years of residing in barangay

NO. OF RESIDENCY	FREQUENCY	PERCENTAGE
Less than 1 year	9	4.5%
1-10 years	35	17.5%
11-20 years	31	15.5%
21-30 years	46	23%
31-40 years	35	17.5%
41-above	44	22%
Total	200	100%

It can be seen from table 5 that most of the respondents are 21-30 years residing in barangay with a frequency of 46 or 23% of the total respondents. Next is 41 and above years with a frequency of 44 or 22% of the total respondents. Following is 1-10 years and 31- 40 years with a frequency of 35 or 17.5% of the total respondents. Then 11-20 years with a frequency of 31 or 15.5% of the total respondents. And the least is less than 1 year with a frequency of 9 or 4.5% of the total respondents. To sum it up, there are a total of 200 respondents or 100%.

2. Percentage of crimes and incidents reported in GMA municipal police station that happened in barangay through hotline number.

Table 6
Crime and incidents through numbers in GMA Municipal Police Station
Between January 1 to September 16, 2018

Incidents or Crimes	Frequency	Percentage
Shooting and Armed Encountered Incident	1	4%
Fire Incident	1	4%
Vehicular or Traffic Incident	2	7%
Founded Dead Body or DUI	2	7%
Others	22	78%
Total	28	100%

It can be seen from table 6 that most crimes and incidents reported to GMA Municipal Police Station through hotline number are others which is related to drugs and troubles with a frequency of 22 or 78%. Next is found dead body or Dui and vehicular or traffic accident with a same frequency of 2 or 7%. And the least is shooting and armed encountered incident and fire incident with a same frequency of 1 or 4%. To sum it up, there is 28 crimes and incidents reported through hotline number or 100%.

3. Level of Awareness about Police Hotline Number

Table 7
Level of Awareness about Police Hotline Number

Level of Awareness	Weighted Mean	Verbal Interpretation	Rank
1. There is an existing police hotline number in the police station near in your locality.	3.84	Moderately Aware	8
2. Police hotline number can be used in cases in emergencies to avoid serious casualties.	4.14	Moderately Aware	4
3. There are limitations and existing law and regulation and pranks, spam and unrelated crime callers.	3.66	Moderately Aware	9
4. The community was informed about the existence of the police hotline number.	3.86	Moderately Aware	7
5. Police hotline number can really prevent the commission of crime.	4.02	Moderately Aware	6
6. The police are conducting programs such as seminars, meetings, disseminations, of posters, fliers etc. Related to police hotline number.	3.63	Moderately Aware	10
7. Police hotline number helps the police officer respond quickly to the incidents.	4.30	Moderately Aware	2
8. Police hotline number is an emergency number which is under the supervision of the PNP that focuses on reporting crime and asking for help through mobile phones.	4.22	Moderately Aware	3
9. There is a local police officer who is responsible in answering the calls from the local police hotline number.	4.13	Moderately Aware	5
10. Any person can call on police hotline number which is free of charge.	4.48	Moderately Aware	1
Composite Mean	4.03	Moderately Aware	

As shown in table 7, “any person can call on police hotline number which is free of charge” ranked 1 as to the level of awareness of respondents to the police hotline number with a weighted mean of 4.48. The second rank is, “police hotline number helps the police officer respond quickly to the incidents” with a weighted mean of 4.30. the third rank is, “ police hotline number is an emergency number which is under the supervision of the PNP that focuses on reporting crimes and asking for help through mobile phones” with a weighted mean of 4.22. the fourth rank is, “ police hotline number can be used in cases of emergencies to avoid serious casualties” with a weighted mean of 4.24. The fifth rank is, “there is local police officer who is responsible in answering the calls from the local police hotline number” with a weighted mean of 4.13. The sixth rank is, “police hotline number can really prevent the commission of crime” with a weighted mean of 4.02. The seventh rank is, “the community was informed about the existence of the police hotline number” with a weighted mean of 3.86. The eighth rank is, “there is an existing police hotline number in the police station near in your locality” with a weighted mean of 3.84. The ninth rank is, “there are limitation and existing law and regulations in prank, spam and unrelated crime callers” with a weighted meetings, dissemination of posters, fliers, etc. related to police hotline number” with a weighted mean of 3.63. The average mean of the level of awareness of the residents is 4.03 with a verbal interpretation of moderately Aware.

4. Factors that affect the awareness about police hotline number

Table 8
Factors that Affect the Awareness about Police Hotline Number

Factors that Affect the Awareness	Weighted Mean	Verbal Interpretation	Rank
1. Conducting seminars and meetings in your community regarding to police hotline number.	3.83	Agree	7
2. Distance of your house from police station.	3.70	Agree	8
3. Establishment of good police-to-community relation.	4.02	Agree	4
4. Having a poster, advertisement or announcement which is indicated the local police hotline number.	3.90	Agree	6
5. Number of incidents happen around your community.	3.58	Agree	10
6. Feeling safe and secured in your community.	3.62	Agree	9
7. Work or profession of members of the family like for example, one of the member of the family are working in their municipal office which they are required to know the emergency number.	3.90	Agree	6
8. Having a self-interest in knowing the police hotline number.	4.28	Agree	2
9. Knowledge in using the technologies such as cell phones, laptops, tablets, etc.	4.36	Agree	1
10. The condition of cellular network signal in the community.	3.94	Agree	5
11. Willingness to attend seminars or meetings regarding to police hotline number.	4.13	Agree	3
Composite Mean	3.93	Agree	

As shown in table 8, “knowledge in using technologies such as cell phones, laptops, tables, etc.” have top the rank in the factors that affect the awareness of respondents through police hotline number with a weighted mean of 4.36. The second rank is, “having a self interest in knowing the police hotline number” with a weighted mean of 4.28. The third rank is, “willingness to attend seminars or meetings regarding to police hotline number” with a weighted mean of 4.13. The fourth rank is, “establishment of good police-to-community relation” with a weighted mean of 4.02. The fifth rank is, “the condition of cellular network signal in the community” with a weighted mean of 3.94. The sixth rank is, “having a poster, advertisement or announcement, which is indicated the local police hotline number” and “work or profession of members of the family like for example, one of the member of the family are working in their municipal office which they are required to know the emergency number” with a weighted mean of 3.90. The seventh rank is, “conducting seminars and meetings in your community regarding to police hotline number” with a weighted mean of 3.83. The eighth rank is, “distance of your house from police station” with a weighted mean of 3.70. The ninth ranks are, “feeling safe and secured in your community” with a weighted mean of 3.62 and the lowest rank is, “number of incidents happened around your community” with the weighted mean of 3.38. The average means of the factors that affect the awareness of the residents is 3.93 with the verbal interpretation of agree.

CONCLUSION

There is no gender and age limit in acknowledging and knowing the police hotline number even at the age of 18 above. It is very important from all of us to be aware to avoid the occurrence of incidents and crimes and provide a good emergency service for all of us. Also in acknowledging the police hotline number, there is no highest educational attainment needed as long as you have knowledge in using technologies to call and know how to observe and to cope up with their surroundings. And even if they are unemployed such as housewife or either a student, they are aware about police hotline number because they mostly care about their safety especially teenager which is a students and a wife working in their house to avoid unnecessary incidents that will happen unexpectedly. And lastly, even though they are residing in their barangay for short term, they are aware about the police hotline number.

The residents are more concern in reporting crimes and incidents related to drug which is one of the major problems of our country today. In the level of awareness, almost all of them are moderately aware when it comes to knowledge and calling to police hotline number with free of charge and all of them can call on it. In the factors that affect the awareness about police hotline number, the most factors are their knowledge about in using technologies like cell phones and tablets where most of the respondents are ranging from 56 and above years of age which affect them in using such technologies. Second, their self-interest in knowing the police hotline number and third is their willingness to participate in meetings and seminars where they rely on others instead of by themselves. Fourth is the police-to-community relationship where the police officers have a negative effect to the residents because of what's happening today. And fifth is, their cellular network signal they have in their community which may affect the numbers of callers.

RECOMMENDATIONS

The residents of the barangay must be aware about police hotline number in their community by cooperating to the barangay officials and to the police and also giving their attention in knowing the police hotline number. The police must conduct more seminars or meetings. They should also provide more posters, advertisement or announcement in every community or they can give fliers where the hotline number is situated so that the residents will become fully aware about police hotline numbers. The barangay official must serve as a guide, help and cooperate to the police to accomplish the goals which are to make the residents of their community to become fully aware about police hotline number. The other government agencies must improve their open-line communication to other government agencies for more effective emergency service. Malls, fast food restaurant and other public establishment must have an initiative to have the local police hotline numbers posted inside their premises. The future researchers must conduct more research related to police hotline number like number of respondents having the police hotline number and to improve their awareness and concluded to another new idea that can really help the residents. Future researcher must also include the use of other statistical treatment to determine the significant relationship of the awareness in police hotline numbers to age, gender, civil status, etc.

REFERENCES

- Lopez. V (2018, June 1) Duterte EO sets 911 as new PHL police, emergency hotline. Retrieved from: <https://www.google.com/amp/www.gmanetwork.com/news/nation/655366/duterte-eo-sets-911-as-new-phl-police-emergency-hotline/story%3famp>
- Chavez. C.A. (2016, July 22) DILG to implement emergency hotline 911 in August. Retrieved from: <http://2016.mb.com.ph/2016/07/22/dilg-2-implement-emergency-hotline-911-in-august>
- PNP (2016, November 22) General Safety and Crime Prevention Information. Retrieved from: <http://www.pnp.com.gov.ph/operations/622-general-safety-and-crime-prevention-information>.
- NCRPO (2018, October 15) Isumbong mo kay Pikoy 0995-0018-886. Retrieved from: <http://ncrpo.pnp.gov.ph>
- Police Scotland (2016, January 15) Campaign launch to raise awareness of 101 phone number. Retrieved from: <http://www.scotland.police.uk/wahats-happening/news/20160january/home-office-101-campaign>.
- Wiltshire Police (2018) "Who you gonna call" launched to raise awareness of appropriate use of 101 and 999. Retrieved from: <http://www.wiltshire.police.uk/article/2372/-Who-You-Gonna-Call-Launched-to-raise-awareness-of-appropriate-use-of-101-and-999>
- GMA News (2018, July 2) NCRPO Text Hotline. Retrieved from: <https://youtu.be/82uNK1U6n4>
- European Emergency Number Association (2018) European Emergency Number 112. Retrieved from: <http://www.eena.org/pages/useful-information#.W0NWt91za00>
- Juleyka W.L (2016, September 28) Police Brutality Leads to Thousands Fewer Calls to 911. Retrieved from: <http://www.google.com/amp/s/www.theatlantic.com/amo/article/501908>
- Ethridge, D.E (2004) Research Methodology in Applied Economics. Retrieved from: <http://research-methodology.net/descriptive-research>
- Fox W. And Bayat M.S (2007) A Guide to Managing Research. Retrieved from: <http://research-methodology.net/descriptive-research>

PHYSICAL PLANT AND FACILITIES ITS RELATIONS TO STUDENT ACADEMIC PERFORMANCE: BASIS FOR COLLEGE MODERNIZATION PROGRAM

Dr. Chanda R. Tingga

INTRODUCTION

The quality and adequacy of physical plant and facilities of a learning institution determine to a large measure the success of its curricular program. In a broad sense, physical plant and facilities include school site, campus, buildings and other infrastructures, equipment and complement institutional and program effectiveness.

The researchers now being much interested in this issue intend to investigate the physical plant and facilities of EARIST Manila provided and what are the relations to the academic performances of the students.

STATEMENT OF THE PROBLEM

The main purpose of this study is to investigate the possible relationship between Physical Plant and facilities to the student academic performance.

Pointedly, the study seeks to answer the following questions:

1. How do the students assess the physical plant and facilities as to:
 - 1.1 Site;
 - 1.2 Campus;
 - 1.3 Buildings;
 - 1.4 Classrooms;
 - 1.5 Offices, Function Rooms and Staff Rooms;
 - 1.6 Medical and Dental Clinic;
 - 1.7 Student Center; and
 - 1.8 Food Services?
2. What is the student academic performance in the last academic year?
3. Is there significant relationship between the physical plant and facilities and student academic performance?
4. Based from the findings, what college modernization program may be proposed?

RESEARCH METHOD USED, RESEARCH LOCALE, AND RESPONDENTS OF THE STUDY, SAMPLING PROCEDURE, INSTRUMENTATION AND DATA ANALYSIS

The researcher's applied a Descriptive method to initiate an investigation on physical plant and facilities and its relation to student academic performance in EARIST Manila specifically in College of Business Administration thru the use of survey questionnaire.

The respondents of this study are composed of students from CBA in all majors at the EARIST Manila.

The researchers prepared one set of questionnaires for the respondents, which consist of three parties:

Part I is for demographic profile in terms of age, sex, civil status, and course.

Part II is the General Average of the students for the last semester.

Part III contains the entire survey questionnaire given by the researchers. The students were asked to rate each statement using Likert scale.

The chronological steps, undergone by the researcher in gathering data are as follows:

1. Construct and develop instruments used in the study.
2. Distributed the questionnaires to the respondents with proper instructions given as guide in accomplishing the questionnaire.
3. Talled the data and information gathered through the survey questionnaire.
4. Consulted and asked the help of a statistician for the treatment and interpretation of data as well as findings.
5. Statistical findings were presented in tabular forms and narratively described and interpreted.
6. Consult the adviser as to the status and progress of the research study.
7. Drafted and encoded the manuscript and readied for final oral defense.

Statistical Analysis of Data

The data collected in the study were organized and classified based on the research design and problems formulated. The data were coded, tallied, tabulated, and tabled to facilitate the presentation and interpretation of results using the following:

1. **Frequency.** It is the actual response to a specific item/question in the questionnaire where the respondent ticks his choice.

2. **Percentage.** To determine the relations of a part to a whole. Are used to express numbers between zero and one.

$$\text{Formula: Percentage} = \frac{F}{N} * 100$$

Where :

f = Number of Responses

n = Total Number of Observation

P = Percentage

3. **Weighted Mean.** It is the sum of the item values divided by the total number of items. It is computed average and its magnitude is influenced by every one of the item

values in the set, and used to describe as set of quantitative data provided the item values that constitute the set are considerably concentrated. It is computed by adding and dividing the sum by the total number of scores.

$$\text{Formula: WM} = \frac{\sum WX}{\sum M}$$

Where : WM = Weighted Mean
 X = Any Particular Value
 M = Associated Mean

4. **Likert Scale.** The data interpreted by using the Four (5) Likert Scale Method, as the criterion which serves as the basis for the interpretation of the data. The concept of the boundary of the numerals will be used as follows:

Scale	Range	Verbal Interpretation	Symbol
5	4.50 – 5.00	Outstanding	O
4	3.50 – 4.49	Very Satisfactory	VS
3	2.50 – 3.49	Satisfactory	S
2	1.50 – 2.49	Fair	F
1	1.00 – 1.49	Poor	P

5. **Ranking.** This was used to determine the order of decreasing or increasing magnitude of variations. The largest frequency is ranked number 5, 4 and so on down to the last rank and number.

6. **Pearson Correlation Coefficient** – is very helpful statistical formula that measures the strength between variables and relationships. In the field of statistics, this formula is often referred to as the Pearson R test. When conducting a statistical test between two variables, it is a good idea to conduct a Pearson correlation coefficient value to determine just how strong that relationship is between those two variables.

FINDINGS AND CONCLUSION

Findings

The salient findings of the study are as follows:

1. The summary on the assessment of Physical Plant and Facilities All (8) items rated Very Satisfactory namely: Offices and Staff rooms; Medical and Dental Clinic; Campus; site and classrooms; student center; buildings; and food service/ canteen.

2. The academic performance in the last academic year with total average of 1.93. For two semesters ratings are: First semester with 2.02; and Second Semester with 1.84.

3. The computed r-values for physical plant and facilities and student academic affairs are site, classrooms, buildings, offices and staff room, campus were negligible and weak correlation. Hence, there is no significant relationship between physical plant and facilities in site, classrooms, buildings, offices and staff room and campus. Therefore, the hypothesis is

accepted. On the other hand, the computed r-values on medical and dental clinic, student center and food service/canteen were moderate correlation. Hence, there is no significant relationship between physical plant and facilities and student academic performance. Therefore, the hypothesis is accepted.

CONCLUSION

Based on the findings of the study, the following conclusions are drawn:

1. Physical plant and facilities found to be highly considered and observe.
2. Majority of the CBA Students have their high and good grades on last two academic years none of them were failed.
3. Physical plant and facilities in site, classrooms, buildings, offices and Medical and dental clinic, student center and food service/canteen have no effects on academic performance of CBA students.

REFERENCES

- Ligayaleah Figueroa, Samsung Lim and Jihyun Lee (2016). "Investigating the relationship between school facilities and academic achievements through geographically weighted regression, annals of GIS," DOI: 10.1080/19475683.2016.1231717 <http://dx.doi.org/10.1080/19475683.2016.1231717> Journal of technology and science education (JOTSE), 4 (1), 39-47<http://dx.doi.org/10.3926/jotse.107>
- Palone, Jim (2012) "Physical plant and facilities department," Malone University
- Mark Raguindin Limon (2016). "The effect of the adequacy of School facilities on students' performance and achievement in technology and livelihood education." www.hrmars.com/journals. URL: <http://dx.doi.org/10.6007/IJARPED/v5-i1/2058>
- Mohammad A. Hassanian (2020). "Quality assessment of a campus Medical Facility: A users approach," <https://www.emerald.com/insight/content/doi/10.1108/IJWHM-01-2020-0001/full/html>
- Khan, Parveen (2012). "Role of physical facilities in teaching learning process," Interdisciplinary journal of Contemporary Research in Business, Pakistan, lrcrb.webs.com
- Robert Scott Mgowen (2010), "The Impact of School Facilities on Student Achievement, Attendance, Behavior, Completion Rate and Teacher Turnover Rate in Selected Texas High Schools."
- Deped (2010), "educational Facilities manual," Pasig City.
- Dimakuta, Nexus Alexander Saidar (2015), "School Plant and Facilities."
- Hezoli, Lovely Ann (2012). "Physical plant and Development Program."

College Research Coordinators

Prof. Rowena Jasmin-Macahiya
CAFA

Prof. Ronald B. Baral
GEN

Prof. Jefferson A. Costales
CAS

Dr. Aguida V. Cabreros
CBPA

Prof. Daisy Mae R. Bongtiwon
CED

Dr. Jeffrey B. Villena
CHTM

Prof. Erwin P. Ordovez
CIT

Dr. Anabel Del Mundo-Riva
CCJE

Prof. Josephine S. Tuvilla
ECC

Dr. Editha V. Pillo
PRESIDENT

Dr. Frederick C. Pena
VPAA

Dr. Grant B. Cornell

VPPREP

RESEARCH SERVICES STAFF

Engr. Rogelio T. Mamaradlo

DIRECTOR

Mrs. Melchorita P. Alvior

EDUCATION PROGRAM SPECIALIST II

In-charge, Journal Reproduction

Engr. Jerome M. Saltorio

EDUCATION PROGRAM SPECIALIST I

In-charge, DOST and IPO Phil Projects

Mr. Richard V. Evangelista

EDUCATION RESEARCH ASSISTANT I

In-charge, Journal Layout and Publication

Mr. Edgardo R. Sison

In-charge, Web Design / Development

Mr. Ernesto C. Pacheco, Jr.

Laboratory Technician, TeDPro LAB

EARIST Research Journal
Volume XXI, No. 29 ISSN 0119-5212
JANUARY - JUNE 2021

Publication Board

Dr. Grant B. Cornell

Editor

Engr. Rogelio T. Mamaradlo

Associate Editor

Editorial Board

Dr. Marlene M. Monterona

Engr. Allan Q. Quismundo

Dr. Jesus S. Paguigan

Dr. Eriberto R. Astorga, Jr.

Secretariat

Mrs. Melchorita P. Alvior

Engr. Jerome M. Saltorio

Circulation Manager/Lay-Out Artist

Mr. Richard V. Evangelista

Lay-Out Artist

Mr. Edgardo R. Sison



Republic of the Philippines
EULOGIO "AMANG" RODRIGUEZ
INSTITUTE OF SCIENCE AND TECHNOLOGY
Nagtahan, Sampaloc Manila



The EARIST Innovation and Technology Support Office (EARIST-ITSO) is one of the franchise patent libraries of the Intellectual Property Office, Philippines (IPO-Phil). Its main objective is to advocate the protection of intellectual property on the academe sector. Its strategy is to have a demystified, democratized, and development-oriented patent system, easy to understand by technical people and laymen, to remove the fear of disclosing their intellectual property and eventually registering them for their own protection.

A demystified patent system is evidenced by the fact that majority of the knowledge generators, researchers, and R and D proponents in the country know how to access global scientific and technology information through the patent databases, and when they wish to protect their innovations, they will know how to obtain patents.

A democratized patent system means that patents is an interdisciplinary concern involving business, researchers, engineering, scientists, faculty, students, government, lawyers and other professions, who will know about and use the patent information, engage in patenting activities and participate in technology commercialization.

A development-oriented patent system implies that the patent system is fashioned as an effective tool to bring progress and prosperity, purposely tailored-fit to the particular needs of, and readily accessible by those who want to use patent information and obtain patents.

Services Offered:

- **Conduct Seminars and Trainings**
- **Patent Database Search**
- **Patent Drafting**
- **Assistance for Commercialization of Technology**

Contact Nos. 0920 946 5806 / 0947 894 0557
(02) 8243 9467 / 8243 9460 / 8243 9466 /
8243 9468 / 8243 9437 Loc. 117



**TECHNOLOGY INNOVATION
AND
SUPPORT OFFICE**